

# Incremental encoders

<b>Miniature magnetic</b>	<b>2430 / 2440 (shaft / hollow shaft)</b>	<b>RS422</b>
---------------------------	---	--------------



Thanks to their non-contact magnetic scanning technology the miniature-format encoders 2430 and 2440 guarantee exceptional ruggedness – and this with a resolution of up to 256 pulses per revolution.

As a result of their compact outer diameter of only 24 mm, they are ideal for use where installation space is restricted.



Incremental encoders

High rotational speed	Temperature range	Shock / vibration resistant	Short-circuit proof	Reverse polarity protection	Magnetic sensor technology

### Magnetically robust

- The non-contact magnetic technology prevents wear and guarantees a long service life.
- Multiple clamping affords high strain relief to the cable outlet, ensuring longer life.
- Wide temperature range from -20°C up to +85°C.
- Flexible connection possibilities: can be supplied with radial or axial cable outlet.

### Compact power

- Resolution up to 256 pulses per revolution.
- Shaft and hollow shaft version.

<b>Order code</b>	<b>8.2430</b>	<b>. X X 6 X . XXXX</b>	If for each parameter of an encoder the <b>underlined preferred option</b> is selected, then the delivery time will be 10 working days for a maximum of 10 pieces. Qts. up to 50 pcs. of these types generally have a delivery time of 15 working days.				
<b>Shaft version</b>	Type	<table border="0" style="font-size: x-small;"> <tr> <td style="border: 1px solid black; padding: 2px;">a</td> <td style="border: 1px solid black; padding: 2px;">b</td> <td style="border: 1px solid black; padding: 2px;">c</td> <td style="border: 1px solid black; padding: 2px;">d</td> <td style="border: 1px solid black; padding: 2px;">e</td> </tr> </table>			a	b	c
a	b	c	d	e			
<b>a Flange</b> <u>1 = ø 24 mm [0.94"]</u> 3 = ø 28 mm [1.10"] 2 = ø 30 mm [1.18"]		<b>d Type of connection</b> 1 = axial cable, 2 m [5.56'] PVC A = axial cable, special length PVC *) <u>2 = radial cable, 2 m [5.56'] PVC</u> B = radial cable, special length PVC *)		<b>e Pulse rate</b> 1 ... 128 (factory programmable) <u>256</u> (e.g. 128 pulses => 0128)			
<b>b Shaft (ø x L)</b> 1 = ø 4 x 10 mm [0.16 x 0.39"] 3 = ø 5 x 10 mm [0.20 x 0.39"], with flat <u>2 = ø 6 x 10 mm [0.24 x 0.39"]</u>		*) Available special lengths (connection types A, B): 3, 5, 8, 10, 15 m [9.84, 16.40, 26.25, 32.80, 49.21'] order code expansion .XXXX = length in dm ex.: 8.2430.126A.0256.0030 (for cable length 3 m)		Optional on request - other pulse rates			
<b>c Output circuit / power supply</b> <u>6 = RS422 (with inverted signal) / 5 V DC</u>							

<b>Order code</b>	<b>8.2440</b>	<b>. 1 X 6 X . XXXX</b>	If for each parameter of an encoder the <b>underlined preferred option</b> is selected, then the delivery time will be 10 working days for a maximum of 10 pieces. Qts. up to 50 pcs. of these types generally have a delivery time of 15 working days.				
<b>Hollow shaft</b>	Type	<table border="0" style="font-size: x-small;"> <tr> <td style="border: 1px solid black; padding: 2px;">a</td> <td style="border: 1px solid black; padding: 2px;">b</td> <td style="border: 1px solid black; padding: 2px;">c</td> <td style="border: 1px solid black; padding: 2px;">d</td> <td style="border: 1px solid black; padding: 2px;">e</td> </tr> </table>			a	b	c
a	b	c	d	e			
<b>a Flange</b> <u>1 = ø 24 mm [0.94"]</u>		<b>d Type of connection</b> 1 = axial cable, 2 m [5.56'] PVC A = axial cable, special length PVC *) <u>2 = radial cable, 2 m [5.56'] PVC</u> B = radial cable, special length PVC *)		<b>e Pulse rate</b> 1 ... 128 (factory programmable) <u>256</u> (e.g. 128 pulses => 0128)			
<b>b Blind hollow shaft</b> (insertion depth max. 14 mm [0.55"]) 1 = ø 4 mm [0.16"] <u>2 = ø 6 mm [0.24"]</u>		*) Available special lengths (connection types A, B): 3, 5, 8, 10, 15 m [9.84, 16.40, 26.25, 32.80, 49.21'] order code expansion .XXXX = length in dm ex.: 8.2440.126A.0256.0030 (for cable length 3 m)		Optional on request - other pulse rates			
<b>c Output circuit / power supply</b> <u>6 = RS422 (with inverted signal) / 5 V DC</u>							

# Incremental encoders

<b>Miniature magnetic</b>	<b>2430 / 2440 (shaft / hollow shaft)</b>	<b>RS422</b>
---------------------------	---	--------------

<b>Mounting accessory for shaft encoders</b>		Order no.
<b>Coupling</b>	bellows coupling ø 15 mm [0.59"] for shaft 4 mm [0.16"]	<b>8.0000.1202.0404</b>

Further accessories can be found in the accessories section or in the accessories area of our website at: [www.kuebler.com/accessories](http://www.kuebler.com/accessories).  
 Additional connectors can be found in the connection technology section or in the connection technology area of our website at: [www.kuebler.com/connection\\_technology](http://www.kuebler.com/connection_technology).

## Technical data

Mechanical characteristics	
<b>Maximum speed</b>	12000 min <sup>-1</sup>
<b>Mass moment of inertia</b>	approx. 0.1 x 10 <sup>-6</sup> kgm <sup>2</sup>
<b>Starting torque - at 20°C [68°F]</b>	< 0.01 Nm
<b>Shaft load capacity</b>	radial 10 N axial 20 N
<b>Weight</b>	approx. 0.06 kg [2.11 oz]
<b>Protection acc. to EN 60529</b>	housing side IP65 (IP67 on request) flange side IP50 (IP67 on request)
<b>Working temperature range</b>	-20°C ... +85°C [-4°F ... +185°F]
<b>Materials</b>	shaft / hollow shaft stainless steel clamping flange MS58
<b>Shock resistance acc. to EN 60068-2-27</b>	1000 m/s <sup>2</sup> , 6 ms
<b>Vibration resistance acc. to EN 60068-2-6</b>	100 m/s <sup>2</sup> , 55 ... 2000 Hz

Electrical characteristics	
<b>Output circuit</b>	RS422 (TTL compatible)
<b>Power supply</b>	5 V DC (±5 %)
<b>Power consumption with inverted signal (no load)</b>	typ. 40 mA max. 90 mA
<b>Permissible load / channel</b>	max. +/- 20 mA
<b>Pulse frequency</b>	max. 300 kHz
<b>Signal level</b>	HIGH min. 2.5 V LOW max. 0.5 V
<b>Rising edge time t<sub>r</sub></b>	max. 200 ns
<b>Falling edge time t<sub>f</sub></b>	max. 200 ns
<b>Min. pulse edge interval</b>	0.5 µs <sup>1)</sup>
<b>Short circuit proof outputs<sup>2)</sup></b>	yes <sup>3)</sup>
<b>Reverse polarity protection of the power supply</b>	no
<b>CE compliant acc. to</b>	EMC guideline 2014/30/EU RoHS guideline 2011/65/EU

## Terminal assignment

Output circuit	Type of connection	Cable (isolate unused wires individually before initial start-up)									
6 with inv. signal	1, 2, A, B	Signal:	0 V	+V	A	$\bar{A}$	B	$\bar{B}$	0	$\bar{0}$	
		Cable colour:	WH	BN	GN	YE	GY	PK	BU	RD	

- +V: Encoder power supply +V DC
- 0 V: Encoder power supply ground GND (0 V)
- A,  $\bar{A}$ : Incremental output channel A
- B,  $\bar{B}$ : Incremental output channel B
- 0,  $\bar{0}$ : Reference signal

1) For max. speed use a counter with input frequency of min. 500 kHz.  
 2) If power supply correctly applied.  
 3) Only one channel allowed to be shorted-out:  
 If +V = 5 V DC short circuit to channel, 0 V, or +V is permitted.

# Incremental encoders

<b>Miniature magnetic</b>	<b>2430 / 2440 (shaft / hollow shaft)</b>	<b>RS422</b>
---------------------------	---	--------------

## Dimensions shaft version

Dimensions in mm [inch]

### Flange type 1, $\varnothing$ 24 [0.94]

- 1 min R50 [1.97]
- 2 3 x M3, 4 [0.16] deep

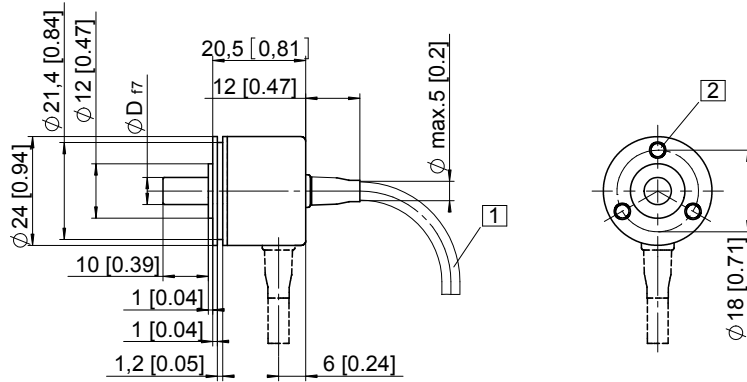

### Flange type 2, $\varnothing$ 30 [1.18]

### Flange type 3, $\varnothing$ 28 [1.10]

- 1 min R50 [1.97]
- 2 2 x M3, 4 [0.16] deep

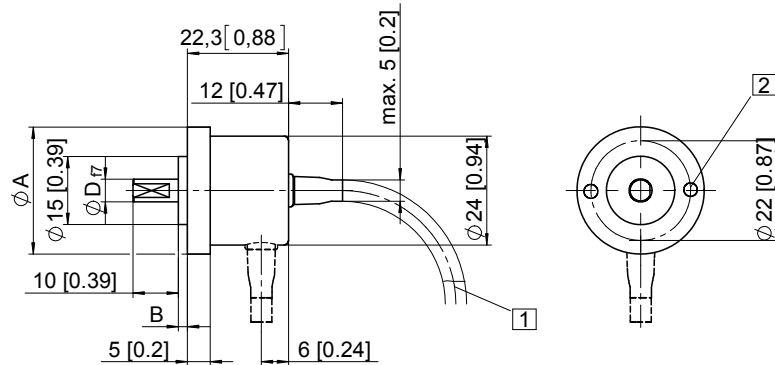

Flange type	A	B
2	$\varnothing$ 30 [1.18]	3 [0.12]
3	$\varnothing$ 28 [1.10]	2 [0.08]

## Dimensions hollow shaft version

Dimensions in mm [inch]

### Flange type 1, $\varnothing$ 24 [0.94]

- 1 4 x M3 DIN 915 - SW1.5

