

Absolute Encoders - Singleturn

ATEX, optical

Sendix 7053 SIL (Shaft)

SSI / BiSS-C + SinCos



Ex protection and Functional Safety in one device.

The absolute singleturn encoders Sendix 7053 SIL are perfectly suited for use in safety-related applications up to SIL3 according to DIN EN ISO 61800-5-2 or PLe to DIN EN ISO 13849.

In addition, these devices ensure Ex protection in a compact 70 mm housing out of seawater-resistant aluminium.



Functional Safety

- Certified by the German Institute for Occupational Safety (IFA)
- Suitable for SIL3 applications acc. to DIN EN ISO 61800-5-2
- Suitable for PLe applications acc. to DIN EN ISO 13849
- SSI or BiSS-C interface with incremental SinCos tracks

ATEX compliant

- “Flameproof-enclosure” version: approved for zone 1, 2 and 21, 22
- Zone 1, 2 and 21, 22:

Order code Shaft version

8.7053SIL . 1 X 2 X . X X 2 1 . XXXX
Type a b c d e f g h i 1)

a Flange

1 = clamping-synchronous flange \varnothing 70 mm, IP67

b Shaft ($\varnothing \times L$)

1 = 12 x 25 mm,
with keyway for 4 x 4 mm key
2 = 10 x 20 mm, with flat

c Interface / Power supply

4 = SSI / BiSS-C + 2048 ppr SinCos track / 10 ... 30 V DC

d Type of connection

1 = axial cable (2 m PUR)
2 = radial cable (2 m PUR)
A = axial cable (length > 2 m)
B = radial cable (length > 2 m)
(preferred lengths, see **i**, e.g.: 0100 = 10 m)

e Code

B = SSI, Binary
C = BiSS-C, Binary
G = SSI, Gray

f Resolution ²⁾

A = 10 bit ST
1 = 11 bit ST
2 = 12 bit ST
3 = 13 bit ST
4 = 14 bit ST
7 = 17 bit ST

g Inputs / Outputs ²⁾

2 = SET, DIR input

h Options

1 = no option

i Cable length in dm ¹⁾

0050 = 5 m
0100 = 10 m
0150 = 15 m

*optional on request
- special cable length*

Further accessories can be found in the Accessories section or in the Accessories area of our website at: www.kuebler.com/accessories.
Additional connectors can be found in the Connection Technology section or in the Connection Technology area of our website at: www.kuebler.com/connection_technology.

You will find an overview of our systems and components for Functional Safety under www.kuebler.com/safety

1) Not applicable with connection types 1 and 2

2) Resolution, preset value and counting direction factory-programmable

Absolute Encoders - Singleturn

ATEX, optical		Sendix 7053 SIL (Shaft)	SSI / BiSS-C + SinCos
Explosion protection			
EC type-examination certificate	PTB09 ATEX 1106 X		
Category (gas)	II 2G Ex d IIC T6		
Category (dust)	II 2D Ex tD A21 IP6X T85°C		
Directive 94/9 EC	EN 60079-0; DIN EN 60079-1 EN 61241-0; DIN EN 61241-1		
Mechanical characteristics			
Max. speed	continuous 6 000 min ⁻¹		
Starting torque	< 0.05 Nm		
Moment of inertia	4.0 x 10 ⁻⁶ kgm ²		
Load capacity of shaft	radial	80 N	
	axial	40 N	
Weight	approx. 0.6 kg		
Protection EN 60 529	IP67		
Working temperature range	-40°C ... +60°C		
Materials	shaft	stainless steel	
	flange / housing	seawater-resistant Al, type AISiMgMn (EN AW-6082) or stainless steel	
	cable	PUR	
Shock resistance acc. EN 60068-2-27	2500 m/s ² , 6 ms		
Vibration resistance acc. EN 60068-2-6	100 m/s ² , 55 ... 2000 Hz		
General electrical characteristics			
Power supply	10 ... 30 V DC		
Current consumption (w/o output load)	max. 45 mA		
Reverse polarity protection for power supply (U _B)	yes		
CE compliant acc. to	EN 61000-6-2, EN 61000-6-4 and EN 61000-6-3		
RoHS compliant acc. to	EU guideline 2002/95/EG		
SSI interface			
Output driver	RS485 Transceiver type		
Permissible load/channel	max. 20 mA		
Signal level	high	typ 3.8 V	
	low at I _{Load} = 20 mA	typ 1.3 V	
Short-circuit proof outputs	yes ¹⁾		
Singleturn resolution	10 ... 14 bit and 17 bit ²⁾		
Number of revolutions	4096 (12 bit)		
Code	Binary or Gray		
SSI clock rate	< 14 bit: 50 kHz ... 2 MHz		
Monoflop time	< 15 μs ²⁾		
Note: if clock starts cycling within monoflop time a second data transfer starts with the same data. If clock starts cycling after monoflop time, the data transfer starts with updated values. The update rate depends on clock speed, data length and monoflop time.			
Data refresh rate	up to 14 bit	< 1 μ	
	for 15 ... 17 bit	< 4 μs	
Status and Parity bit	on request		
SET input			
Input	high active		
Input type	Comparator		
Signal level	high	min. 60 % of +V max. +V	
	low	max. 25 % of +V (+V = Power supply)	
Input current	< 0.5 mA		
Min. pulse duration (SET)	10 ms		
Timeout after SET signal	14 ms		
Response time (DIR input)	1 ms		
The encoder can be set to zero at any position by means of a High signal on the SET input. Other preset values can be factory-programmed. The SET input has a signal delay time of approximately 1 ms. Once the SET function has been triggered, the encoder requires an internal processing time of approximately 15 ms before the new position data can be read.			
DIR input			
A High signal switches the direction of rotation from the default CW to CCW. The reverse function can also be factory-programmed. If DIR is reversed when the device is already switched on, this will be interpreted as an error. The status output switches to Low.			
Status output			
Output driver	Open Collector, internal pull-up resistor 22 kOhm		
Permissible load	max. 20 mA		
Signal level	high	+V	
	low	< 1 V	
Active at	low		
The status output serves to display various alarm or error messages. The status output is high (Open Collector with internal pull-up 22k) in normal operation.			
Power-ON delay			
After Power-ON, the device requires a time of approximately 150 ms before valid data can be read.			
BiSS-C Interface			
Singleturn resolution	10 ... 14 bit and 17 bit ²⁾		
Code	Binary		
Clock rate	up to 10 MHz		
Max. update rate	< 10 μs, depends on the clock rate and the data length		
Data refresh rate	≤ 1 μs		
Note::	<ul style="list-style-type: none"> - Bidirectional, factory programmable parameters are: resolution, code, direction, alarms and warnings - CRC data verification 		

1) Short-circuit with 0V or output, only one channel at a time, supply voltage correctly applied
2) Other options on request

Absolute Encoders - Singleturn

ATEX, optical

Sendix 7053 SIL (Shaft)

SSI / BiSS-C + SinCos

Terminal assignment

Interface	Type of connection	Features	Cable														
			Signal:	GND	+V	+C	-C	+D	-D	SET	DIR	A	\bar{A}	B	\bar{B}	PE	PE
4	1, 2, A, B	SET, DIR	Cable marking:	6	1	2	3	4	5	11	12	7	8	9	10	YE/GN	Shield

+V: Encoder power supply +V DC

GND: Encoder Ground GND (0V)

+C, -C: Clock signal

+D, -D: Data signal

SET: Set input. The current position becomes defined as position zero.

DIR: Direction input. If this input is active, output values are decreasing when shaft is turned clockwise

PE: Protective earth

A, \bar{A} : Incremental output channel A

B, \bar{B} : Incremental output channel B

Dimensions

Shaft type 1 with axial cable outlet

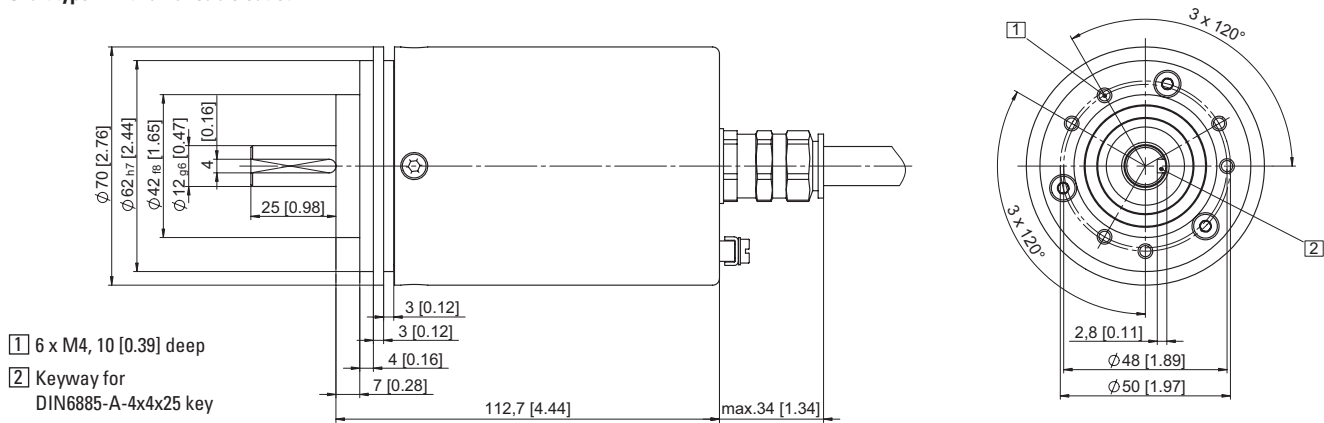

Shaft type 2 with radial cable outlet

