

WT 11- P440 FGS

Photoelectric Proximity Switch

Dimension illustration

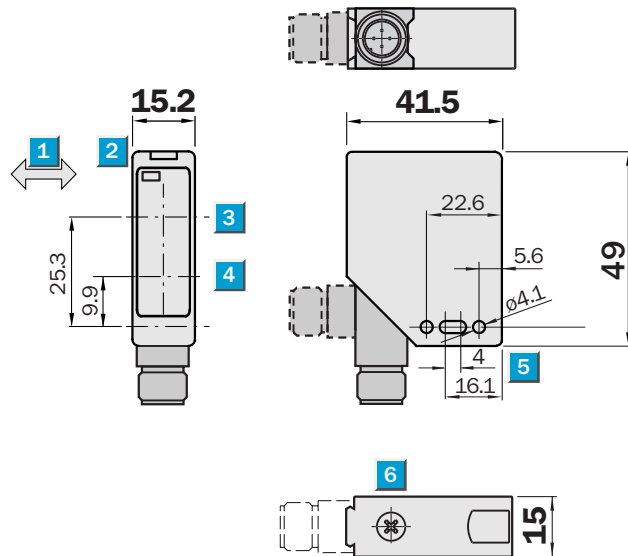

Setting options

WT 11-P440

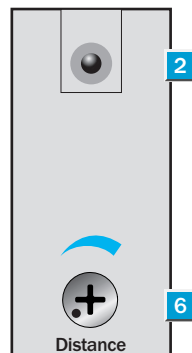

- 1 Standard direction of the material being scanned
- 2 LED signal strength indicator
- 3 Transmitter's optical axis
- 4 Receiver's optical axis
- 5 Mounting holes \varnothing 4.1 mm
- 6 Scanning distance adjuster



Scanning distance
35...100 mm

Photoelectric proximity switch

- Red light
- Insensitive to ambient light sources
- M 12 plug rotatable by 90°
- Adjustable foreground suppression and scanning distance

Connection type

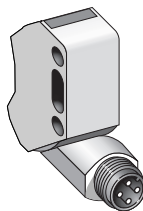
WT 11-P440



4-pin, M 12

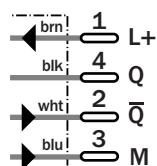

Technical data		WT 11-	P440									
Scanning distance	35...100 mm, adjustable											
Light source ¹⁾, light type	LED, red light											
Light spot size	3 x 3 mm at 60 mm											
Supply voltage V_s	10...30 V DC ²⁾											
Ripple ³⁾	$\leq 5 V_{pp}$											
Current consumption ⁴⁾	≤ 30 mA											
Switching outputs	PNP, Q and \bar{Q}											
Output current I_A max.	≤ 100 mA											
Response time ⁵⁾	≤ 625 μ s											
Max. switching frequency ⁶⁾	800/s											
Connection types	4-pin, M 12 plug ⁷⁾											
VDE protection class⁸⁾	\square											
Circuit protection⁹⁾	A, B, C											
Enclosure rating	IP 65											
Ambient temperature T_A	Operation -20 °C... $+60$ °C Storage -20 °C... $+75$ °C											
Weight	With plug: 120 g											
Housing material	Plastic, ABS											

¹⁾ Average service life 100,000 h at $T_A = +25$ °C
²⁾ Limit values
³⁾ May not exceed or fall short of V_s tolerances

⁴⁾ Without load
⁵⁾ Signal transit time with resistive load
⁶⁾ With light/dark ratio 1:1
⁷⁾ Do not bend below 0 °C
⁸⁾ Reference voltage 50 V DC

⁹⁾ A = V_s connections reverse-polarity protected
 B = Output Q and \bar{Q} short-circuit protected
 C = Interference pulse suppression

Scanning distance	Order information	
	Type	Part no.
	WT 11-P440	1 022 049

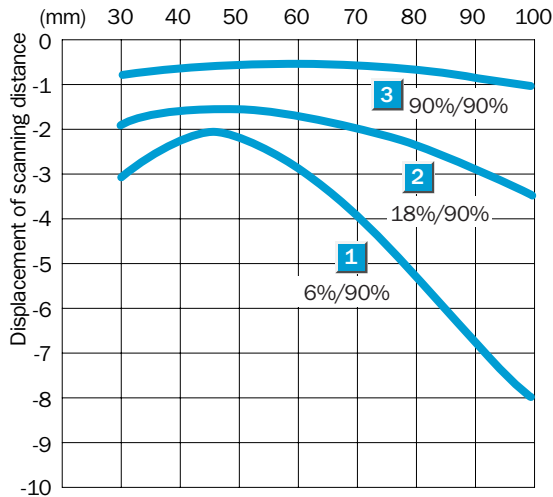

Great Britain
 Erwin Sick Ltd.
 Waldkirch House
 39 Hedley Road, St. Albans
 Hertfordshire AL 1 5BN
 ☎ +44 17 27-83 11 21
 Fax +44 17 27-85 67 67
 erwin@sick.co.uk

USA
 SICK, Inc.
 6900 West 110th Street
 Bloomington, MN 55438
 ☎ +1 (952) 9 41-67 80
 Fax +1 (952) 9 41-92 87
 WATS: 1-800-325-7425
 info@sickoptics.com

Australia
 Erwin Sick Optic-Electronic
 Pty. Ltd. Head Office, P.O. Box 214
 899 Heidelberg Road
 Ivanhoe, Vic. 3079, Australia
 ☎ +61 39 49 74 10 0
 (0 08) 33 48 02 - toll free
 Fax +61 39 49 71 18 7
 sick@werple.net.au