

Contents

Glossary	General	8		
	Electrical	11		
	Standards	13		
Inductive proximity sensors	Operating principle	14		
	Glossary	15		
	Installation notes	16		
	Selection table	18		
	Type code	19		
	Series	DC 3/4-wire	IM 04	20
			IM 05	22
			IM 08	24
			IM 12	30
			IM 18	40
			IM 30	50
			IH 03	56
			IH 04	58
			IH 06	60
			IQ 05	64
			IQ 08	66
			IQ 10	68
			IQ 12	70
			IQ 40	72
			IQ 80	76
	Series	DC 2-wire	IM 12	78
			IM 18	80
			IM 30	82
Series	AC, AC/DC	IM 12	84	
		IM 18	86	
		IM 30	88	
		IH 20	90	
		IH 34	92	
		IQ 40	94	
		IQ 80	96	
Series	NAMUR	IM 08	98	
		IM 12	100	
		IM 18	102	
		IM 30	104	
Capacitive proximity sensors	Operating principle	106		
	Selection table	107		
	Type code	107		
	Series	DC	CM 18	108
			CM 30	110
		CQ 35	112	

Magnetic proximity sensors	Operating principle	114	
	Glossary	115	
	Installation notes	118	
	Selection table	119	
	Type code	119	
	Series	DC	
		MM 08	120
		MM 12	122
		MM 18	124
		MQ 10	126
	Series	NAMUR	
	MM 12	128	
	MM 18	130	
Magnetic cylinder sensors	Operating principle	132	
	Product overview	133	
	Type code	135	
	Series	DC	
		MZ R1	136
		MZ R2	138
		MZ Z1	140
		MZ Z2	142
		MZ P3	144
		MZ P4	146
		MZ K1	148
		MZ K3	150
		MZ F1	152
		MZ T1	154
		RZ T1	156
		MZ U2	158
		Series	NAMUR
		MZR2	160
	MZ Z1	162	
	MZ P3	164	
	MZ P4	166	
Accessories, control units	Control unit EN 2	168	
	Isolating Control unit EN 2 Ex	172	
	Round connectors	174	
	Magnets	176	
	Mounting brackets	177	
Index	Type designation	178	
	Order number	182	
Sensors from SICK		187	

Inductive proximity sensors
 Capacitive proximity sensors
 Magnetic proximity sensors
 Magnetic cylinder sensors
 Accessories, control units

Glossary

General

Active switching zone

Area above the sensing face in which a proximity sensor responds by a change in switching status when attenuating material is brought nearer.

Cables

PUR cable

- ▶ oil-resistant cable
- ▶ not resistant to hydrolysis

PVC cable

- ▶ not suitable for continuous use in environments containing oil
- ▶ not ozone- or UV-resistant

PUR-PVC cable

- ▶ PVC cable coated with PUR

The cables must not be moved in temperatures below -5 °C otherwise they may rupture.

Complementary output

A DC 4-wire with one NO and NC output that can be used at the same time.

Continuous current I_a

Current at which the proximity sensor can function reliably.

Enclosure rating

The conditions for the enclosure rating IP 68 are the following at the SICK AG:

- 1 m water depth
- temperature of 20° C
- permanent immersion

EMC

Electromagnetic compatibility

Flush installation

A proximity sensor can be embedded in an attenuating material so that it is flush with the active surface.

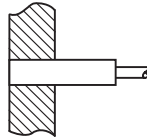

Housing material

- ▶ Brass, nickel-plated
- ▶ Stainless steel
- ▶ Aluminium
- ▶ Plastic (PA12, PBT, PPE)

If the sensors are to be frequently or continuously exposed to chemicals, an application test must be performed. Contact SICK AG for further information.

Hysteresis H

The hysteresis is the positional difference between the activation and deactivation point for attenuating material as it is brought closer or moved away. It is required to ensure a smooth, stable switching action. It is given as a percentage of the real sensing range or in mm.

Minimum load current

Smallest load current that must flow with connected output in order to ensure the reliable operation of 2-wire proximity sensors.

Non-flush installation

A proximity sensor must be installed in such a way that a free-zone is maintained.

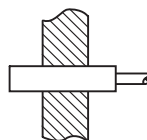

NPN output

Proximity sensors with NPN output switch the negative potential to the load. They are also described as negative-switching or current-sinking.

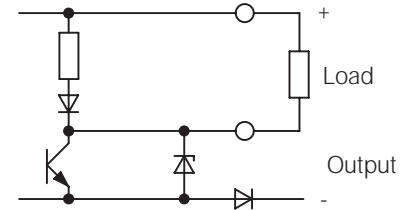

Output function

Normally open: A proximity sensor with make function is disabled in the unattenuated state (high resistance) and is switched in the attenuated state (low resistance).



Normally closed: A proximity sensor with brake function is switched in the unattenuated state (low resistance) and disabled in the attenuated state (high resistance).



Operating voltage U_o

Voltage range in which the proximity sensor can function reliably.

Overload resistance

See also short-circuit protection. The response threshold for overload protection is greater than the value for continuous current-carrying capacity.

Peak current I_k

Current that may flow for a specified period at a defined switching frequency without destroying the proximity sensor.

PNP output

Proximity sensors with PNP output switch the positive potential to the load. They are also described as positive-switching or current-sourcing.

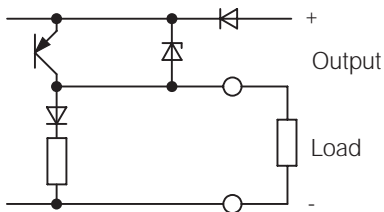

Power-up pulse suppression

The power-up pulse suppression ensures that no incorrect switching signal is sent to the output between the time when the operating voltage is applied and when the oscillator begins to oscillate.

Repeatability R

Switching point difference for the useful sensing range between two consecutive measurements under identical conditions.

Residual current I_r

The residual current is used to supply power to the 2-wire sensors and also flows across the load if the output is disabled.

Reverse polarity protected

(with NAMUR sensor to EN 50227)
The connections of the proximity sensor can be connected to the wrong terminals without the sensor being damaged.

Reverse polarity protection

An internal protection circuit prevents the DC 3/4-wire proximity sensors from being destroyed if the supply voltage connections are incorrectly connected, and also ensures that no misoperation can occur which would result in an undesired signal being issued.

Ripple U_{pp}

The DC operating voltage of the ripple voltage content (maximum permissible peak value, given in % of U_b).

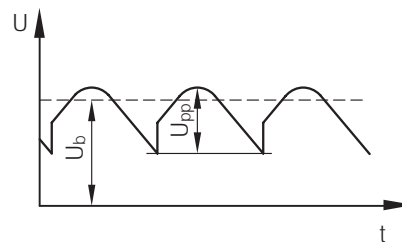

Sensing face

Surface of a proximity sensor to which the sensing range relates.

Sensing range

The sensing range of a proximity sensor is the distance at which one of the measuring plates being moved axially towards the active surface triggers a signal change.

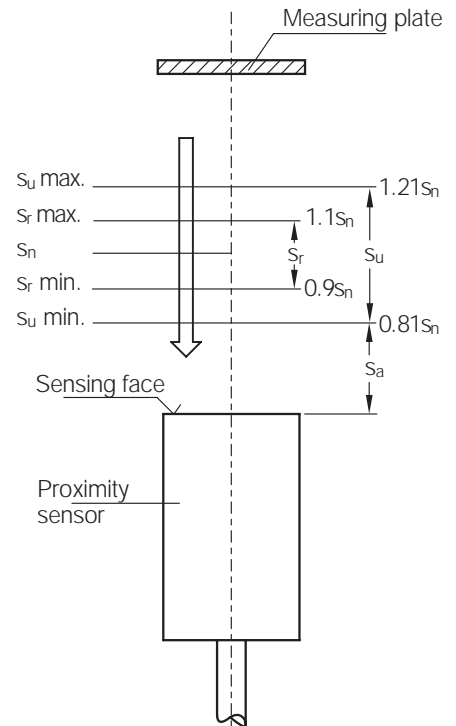

Rated sensing range s_n :
Device characteristics

Real sensing range s_r :
 $0.9 s_n \leq s_r \leq 1.1 s_n$

Useful sensing range s_u :
 $0.9 s_r \leq s_u \leq 1.1 s_r$

Actuation distance s_a :
The actuation distance is the distance at which a proximity sensor reacts under specified temperature and voltage conditions.
It is between 0% and 81% of the rated sensing range.

Glossary

General

Shock stress

Pulse shape: semi-sinoidal
 Acceleration: $\leq 30 g_n$
 Pulse length: 11 ms

Short-circuit protection

Proximity sensors with short-circuit protection cannot be destroyed by either overloading or a direct short-circuit. When the triggering threshold is exceeded, the output is disabled and then periodically (in cycles) polled to establish whether the short-circuit still exists. An automatic reset is performed once the short-circuit has been eliminated.

Short-circuit protection (with NAMUR sensor to EN 50227)

The proximity sensor is not destroyed if the load short-circuits or in the case of a short-circuit to ground at the output.

Status indicator

The forced triggering of the output (low-resistance) is indicated by an LED. With some sensors, standby is indicated by a second LED.

Switching frequency f

Maximum number of switching actions per second.

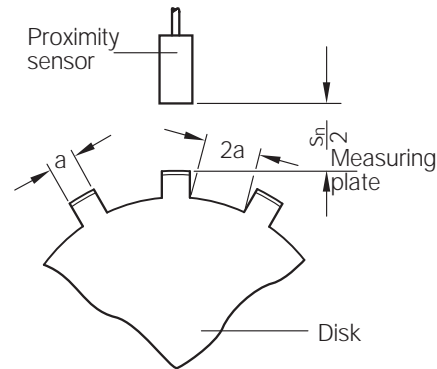

Temperature drift

Shifting of the switching point caused by a change in ambient temperature.

Time delay before availability t_v

Time required by the proximity sensor to become operational after the operating voltage is applied.

Vibration stress

Frequency range: 10 to 55 Hz
 Amplitude: 1 mm
 Vibration length: 5 min
 Endurance at resonance frequency or at 55 Hz: 30 min. in each axis

Voltage drop U_d (at I_a max)

Reduction in voltage occurring at maximum load current across the switching module of the proximity sensor. Special attention must be paid to this in the case of serial connections.

Wire-break protection

If one of the supply lines is broken, the output remains disabled (no misoperation).

DC 3/4-wire sensors

Apart from the oscillator, direct-current sensors also have an output amplifier. They are supplied as 3/4-wire sensors with NO, NC, complementary or programmable outputs. Sensors of this type have short-circuit, reverse-polarity protection, and power-up pulse suppression. The residual current is negligible. A capacitive load of up to 0.15 μF can be connected. These sensors are supplied as:

- NC, negative-switching (NPN)
- NC, positive-switching (PNP)
- NO, negative-switching (NPN)
- NO, positive-switching (PNP)
- programmable NO/NC, negative-switching (NPN)
- programmable NO/NC, positive-switching (PNP)
- complementary NO and NC negative-switching (NPN)
- complementary NO and NC positive-switching (PNP)
- free configurable as
 - NO, negative-switching (NPN)
 - NO, positive-switching (PNP)
 - NC, negative-switching (NPN)
 - NC, positive-switching (PNP)

Serial connection of 3-wire sensors:

With series connection, the voltage drops and the standby delay times of the individual proximity sensors are added together.

That is the reason for a reduced load voltage.

PNP-connection:

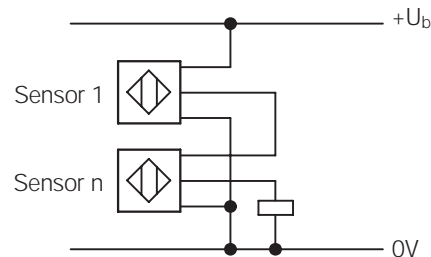

Parallel connection of 3-wire sensors:

The LEDs of all proximity sensors light up if only one sensor is active. It is therefore advisable to install blocking diodes in the switching output.

PNP-connection:

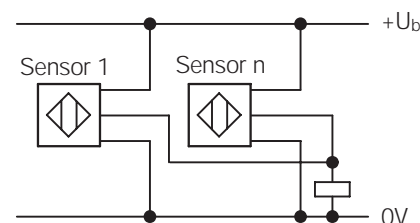

AC/DC 2-wire sensors

Apart from the oscillator, alternating current 2-wire sensors also have a transistor as an output amplifier. These sensors are directly operated in series with the load. As a result, a small residual current flows across the load when the sensors are disabled. In forced-tripping mode, a drop in voltage also occurs at the sensor.

These points are particularly relevant in the case of parallel and serial connections. These sensors are supplied as:

- normally open
- normally closed
- programmable NO/NC

Serial connection

of 2-wire sensors:
Not recommended

Parallel connection of 2-wire sensors:

In the case of parallel connection, the residual currents of all proximity sensors are added together.

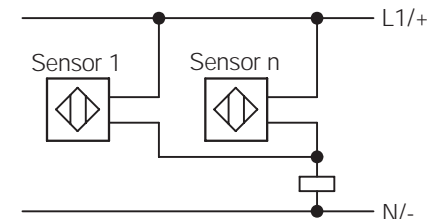

Protection class

Sensors not bearing the symbol  must be operated at power sources which comply with the safety requirements for extra-low voltage as per VDE 100.

Glossary

Electrical

NAMUR sensor to EN 50227

These sensors are 2-wire electric position encoders which are usually connected to the control input of a switching amplifier.

The direct-current source of the switching amplifier provides the sensors with power. If metal or magnets are positioned close to the sensors, the internal resistance of the NAMUR sensor changes (constant distance/current curve, see graph). The change in internal resistance is evaluated by the switching amplifier and converted into a digital signal.

All NAMUR sensors have a classification for division 1 areas. They can be used in combination with Isolating units.

Typical standard operating values for a control circuit with intrinsic safety protection:

$$\begin{aligned}
 U_N &= 8.2 \text{ V} \\
 R_i &= 1 \text{ KW} \\
 I_{\text{attenuated}} &< 1.2 \text{ mA} \\
 I_{\text{unattenuated}} &> 2.1 \text{ mA}
 \end{aligned}$$

The falling curve from right to left only applies to inductive sensors. The curve for magnetic sensors has exactly the same characteristics, but ascends from right to left:

$$\begin{aligned}
 I_{\text{attenuated}} &> 2.1 \text{ mA} \\
 I_{\text{unattenuated}} &< 1.2 \text{ mA}
 \end{aligned}$$

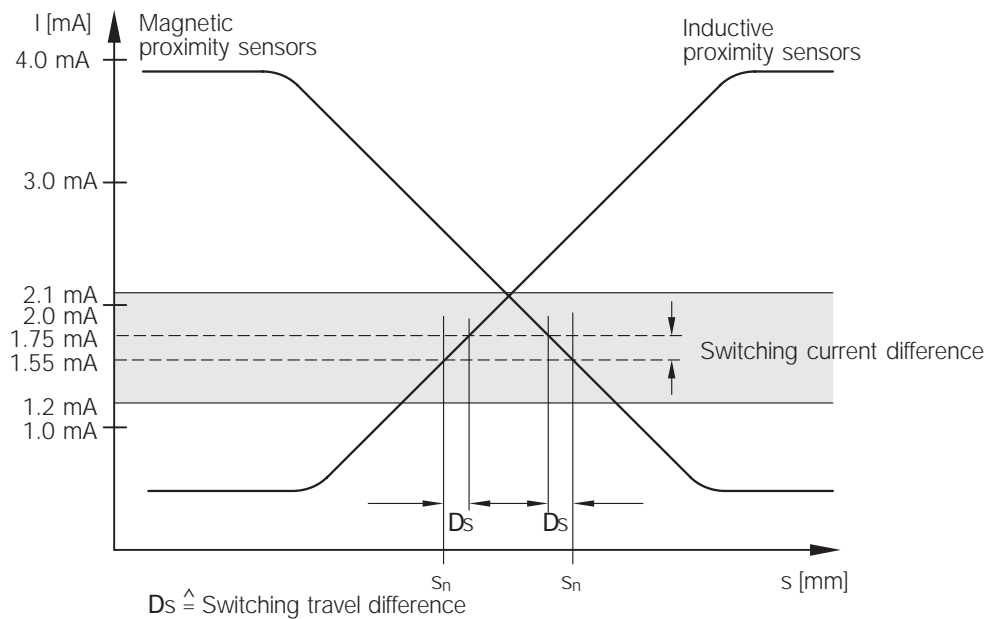

Glossary

Standards and conformities

Standards

EN 60 947-1 - IEC 947-1 DIN VDE 0660 Part 100	Low-voltage switchgear; part 1: General specifications
EN 60 947-5-1 - IEC 947-5-1 DIN VDE 0660 Part 200	Low-voltage switchgear; part 5: Controllers and switching elements Section 1: Electromechanical controllers
EN 60 947-5-2 - IEC 947-5-2 DIN VDE 0660 Part 208	Switchgear; low-voltage switchgear; auxiliary circuit switch; additional specifications for inductive proximity switches
IEC 664 DIN VDE 0110	Specification for measuring air and creepage distances of electric equipment
EN 60 204-1 - IEC 204-1 DIN VDE 113 Part 1	Electric components in industrial machines; Part 1: General requirements
DIN VDE 0160	Components in power systems with electronic equipment
EN 60 529 - IEC 529	Enclosure ratings provided by housing (IP code)
EN 50 227	NAMUR - electric position encoder - direct-current interface for position encoder and switching amplifier

Conformities



Directives for consumer and capital goods entering the European market have been established by the EU commission to standardise the European single market. To indicate fulfilment of these directives, manufacturers attach the "CE-symbol" to their products.



This symbol also issued by the Underwriters Laboratories bears the letter "L" ("listed". This means that the machine has been granted an individual approval with an approval number. This symbol permits the checking of product's mass production at any time and without prior notice.



The Canadian operating regulations for electrical plants and components are subject to the CEC (Canadian Electrical Code) which describes CSA conformity for all machines. The Canadian Standard Association issues the CSA symbol after the testing of individual components.

Operating Principle

Inductive proximity sensors

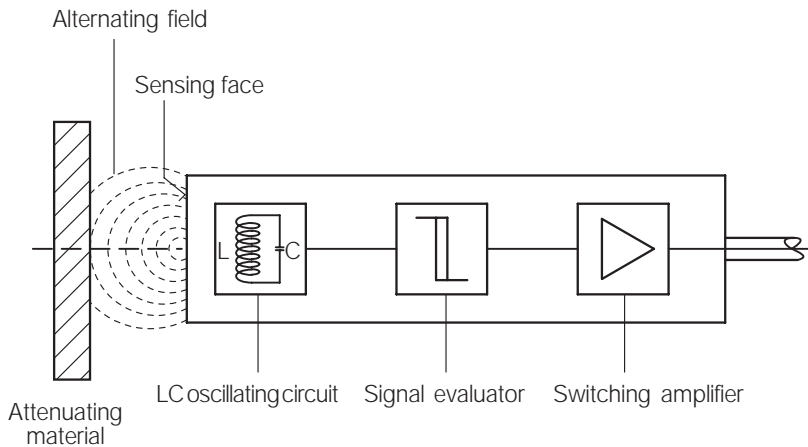

An inductive proximity sensor comprises an LC oscillating circuit, a signal evaluator, and a switching amplifier.

The coil of this oscillating circuit generates a high-frequency electromagnetic alternating field. This field is emitted at the sensing face of the sensor.

If attenuating material nears the sensing face, eddy currents are generated in the case of non-ferrous metals.

In the case of ferromagnetic metals, hysteresis and eddy-current loss also occurs.

These losses draw energy from the oscillating circuit and reduce oscillation. The signal evaluator detects this reduction and converts it into a switching signal.

The terms "attenuated" and "unattenuated" are used to describe the two switching states of the inductive proximity sensors.

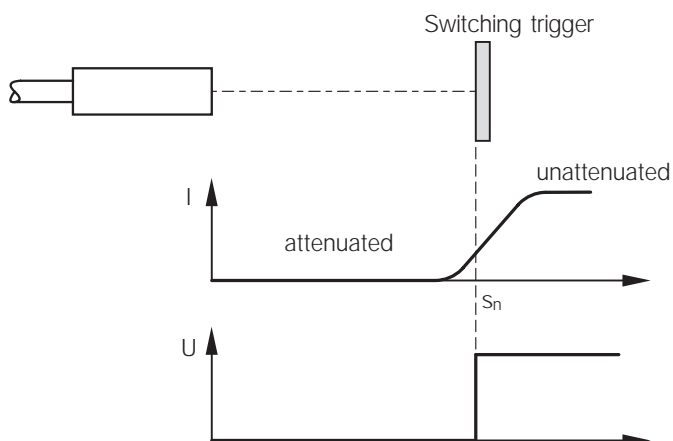

Response curve for inductive proximity sensors

The specified sensing ranges are determined in the case of axial approach along the reference axis of the sensor.

Radial approach results in a reduction of the sensing range. The edge of the switching trigger has only a small surface area. As a result, less eddy-current losses occur. The sensor therefore only reacts if the switching trigger laterally enters the alternating field relatively close to the sensing face. In the case of axial approach, the full surface of the switching trigger is exposed to the scattered electromagnetic field. Axial alignment therefore provides the maximum sensing range.

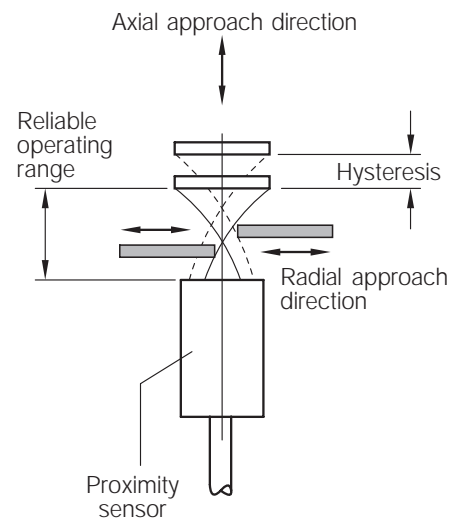

Rated switching trigger

All sensing range measurements must be performed by axially moving a standard square measuring plate made of St37 (1 mm thick) through the alternating field. The length of the switching trigger sides is equal to the diameter of the response area or is $3 s_n$. The larger value should be taken.

When proximity sensors are installed, the reliable sensing range (81 % of s_n) should always be used as the basis. The exact switching point must be set by means of fine adjustment.

Reduction factor R_M

The specified sensing ranges all relate to St37. Considerable reductions in distance sometimes occur in the case of other materials.

Approximate reference values, which can vary from type to type:

St37 (Fe)	1
Stainless steel (V2A)	0.8
Aluminium (solid)	0.45
Copper (Cu)	0.4

These correction factors must be taken into consideration when selecting actuation elements or when calibrating to objects made of the respective alloys.

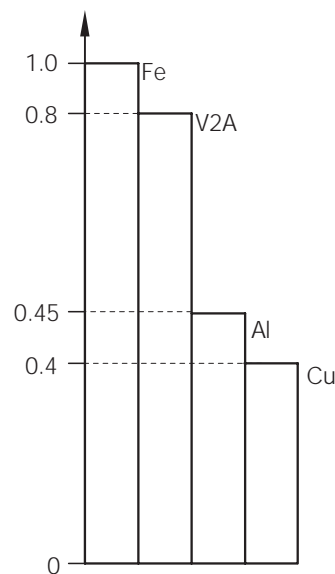

Installation Notes

Inductive proximity sensors

Flush installation in metal

Proximity sensors for flush installation are shielded internally around the ferrite core. As a result, the sensor can be embedded in the metal up to the sensing face.

Proximity sensors for flush installation have a smaller sensing range compared to proximity sensors for non-flush installation with the same shape and design.

Exceeding zone

These sensors with enhanced sensing range are not flush installable in metal:

Type	Exceeding zone
IM12-04B ...	0,1 x d
IM18-08B ...	0,1 x d
IM30-15B ...	0,1 x d
IH06-02B ...	2 mm

Flush installation:

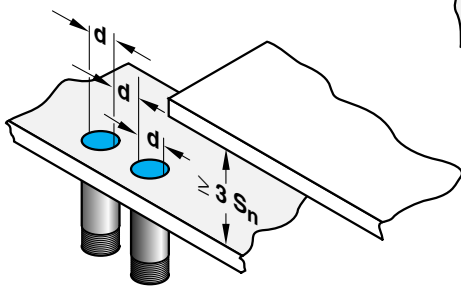

Non-flush installation in metal

With proximity sensors for non-flush installation, a metal-free zone must be maintained owing to the scattered field distribution.

Non-flush installation:

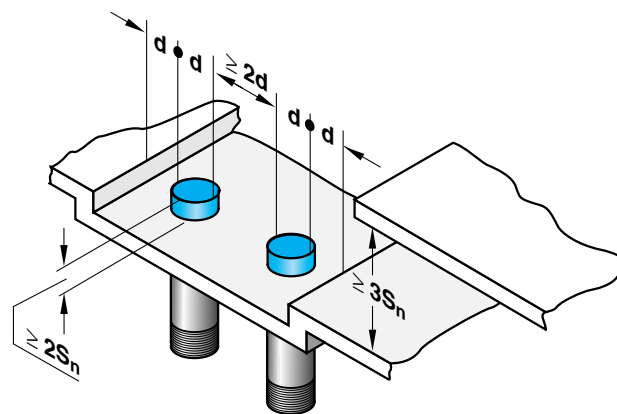

Opposite installation:

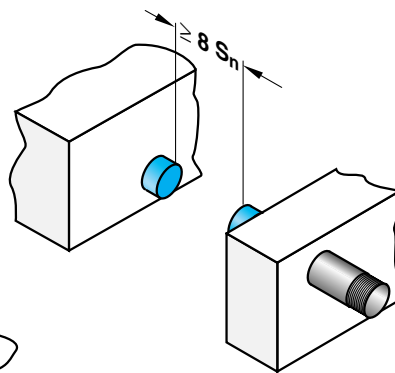

Cylindrical design

General installation notes for cylindrical design for flush and non-flush installation in metal:

Cuboidal design

General installation notes for cuboidal design in metal:

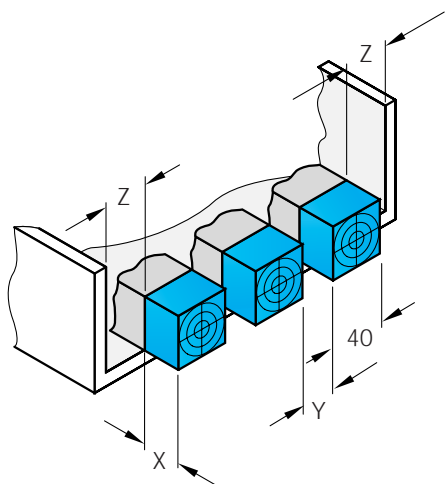

design	in mm		
	X	Y	Z
IQ40-15B	0	40	0
IQ40-20B	0	40	0
IQ40-20N	0	80	80
IQ40-35N	40	80	80

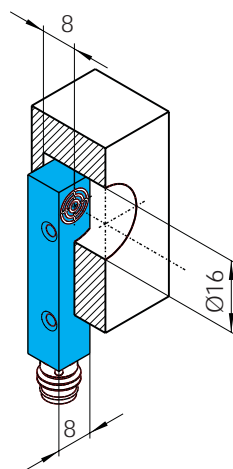
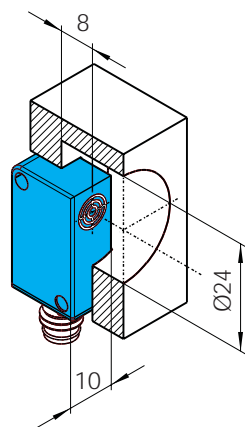
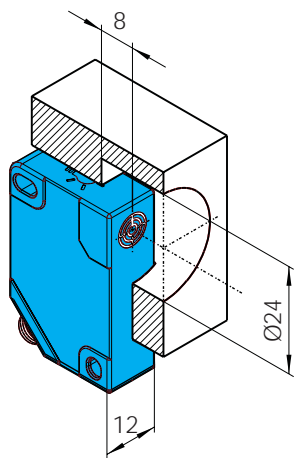

design	in mm
	Y
IQ08-02B ...	8
IQ08-04N ...	16
IQ10-03B ...	10
IQ10-06N ...	20
IQ12-03B ...	12
IQ12-06N ...	24

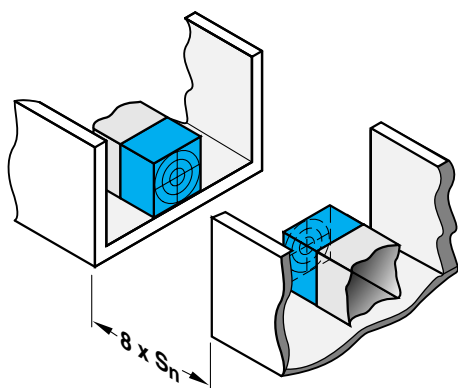

Selection Table

Inductive proximity sensors

Series	Housing			Sensing range s_n in mm		Switching- output		Output function			Connection type			Electr. config.	Page
	Design	Size in mm	Material	Flush	Non flush	PNP	NPN	NO	NC	NO/NC progr./compl.	Cable	Connector	Terminals		
IM04	Cylinder with thread	M4	Brass	0,6		•	•	•			•			DC 3-w.	20
IM05		M5	Brass	0,8		•	•	•			•	•		DC 3-w.	22
IM08		M8	Brass	1,5/2	2,5/4	•	•	•	•		•	•		DC 3-w.	24
IM12		M12	Brass	2/4	4/8	•	•	•	•	•	•	•		DC 3/4-w.	30
IM18		M18	Brass	5/8	8/12	•	•	•	•	•	•	•		DC 3/4-w.	40
IM30		M30	Brass	10/15	15/20	•	•	•	•			•	•	DC 3-w.	50
IH03	Barrel, smooth	Ø3	Stainless steel	0,6		•	•	•			•			DC 3-w.	56
IH04		Ø4	Stainless steel	0,8		•	•	•			•	•		DC 3-w.	58
IH06		Ø6,5	Stainless steel	1,5/2	4	•	•	•			•	•		DC 3-w.	60
IQ05	Cuboid	5x5x25	Brass	0,8		•	•	•			•			DC 3-w.	64
IQ08		8x40/8x49	Plastic	2	4	•	•	•			•	•		DC 3-w.	66
IQ10		10x28/16x37	Plastic	3	6	•	•	•			•	•		DC 3-w.	68
IQ12		12x40/26x49	Plastic	3	6	•	•	•			•	•		DC 3-w.	70
IQ40		41x41x121	Plastic	15	20	•				•			•	DC 3-w.	72
IQ40		40x40x66	Plastic	15/20	35	•		•		•		•		DC 3/4-w.	74
IQ80		80x40x105	Plastic		60	•				•			•	DC 3-w.	76
IM12	Cylinder with thread	M12	Brass	2	4			•			•	•		DC 2-w.	78
IM18		M18	Brass	5	8			•			•	•		DC 2-w.	80
IM30		M30	Brass	10	15			•			•	•		DC 2-w.	82
IM12	Cylinder with thread	M12	Brass	2	4			•	•		•			AC	84
IM18		M18	Brass	5	8			•	•		•			AC/DC	86
IM30		M30	Brass	10	15			•	•		•			AC/DC	88
IH20	Barrel, smooth	Ø20	Plastic		10			•			•			AC/DC	90
IH34		Ø34	Plastic		30			•	•		•			AC/DC	92
IQ40	Cuboid	41x41x121	Plastic	15	20					•			•	AC/DC	94
IQ80		80x40x105	Plastic		60					•			•	AC/DC	96
IM08	Cylinder with thread	M8	Brass	1							•			NAMUR	98
IM12		M12	Brass	2	4						•			NAMUR	100
IM18		M18	Brass	5	8						•			NAMUR	102
IM30		M30	Brass	10	15						•			NAMUR	104

Type Code

Inductive proximity sensors

Character	1	2	3	4	5	6	7	8	9	10	11	12	13	14	Character
	I	M	1	2	-	O	2	B	P	S	-	Z	U	O	
1 Sensor technology I Inductive														other codes K Short body housing	14
2 Design H Barrel M Cylinder with thread Q Cuboid														Connection W Cable, PVC U Cable, PUR-PVC P Cable with connector, M8x1 T Connector, M8x1 C Connector, M12x1 K Terminals	13
3/4 Housing shape 03 04 05 06 08 10 12 Diameter 18 or 20 edge length of 30 sensing face 34 40 80														Housing material Z Ms, nickel-plated V Stainless steel K Plastic	12
6/7/8 Sensing range/ installation B Flush N Non-flush 02B 2 mm; flush 04N 4 mm; non-flush 1B5 1.5 mm; flush 2N5 2.5 mm; non-flush														Output S NO O NC P Programmable/complementary N NAMUR	10
														Interface P DC (3/4-wire) PNP N DC (3/4-wire) NPN C DC (4-wire) PNP or NPN D DC (2-wire) A AC 2-wire U AC/DC 2-wire - NAMUR	9



Miniature series

Inductive proximity sensors

IM 04 series, sensing range 0.6 mm

DC 3-wire, miniature metal housing

Dimensions in mm

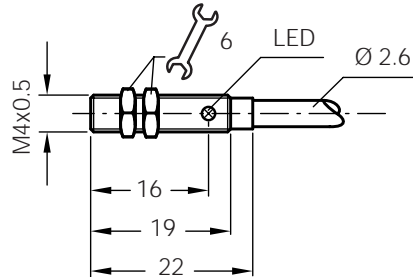

Features



- ▶ Can be installed flush
- ▶ PNP or NPN output
- ▶ Normally open function
- ▶ High switching frequency
- ▶ Short-circuit protection (pulsed)
- ▶ Robust brass housing, nickel-plated with fine thread M4 x 0.5 mm
- ▶ Cable
- ▶ Enclosure rating IP 67
- ▶ LED status indicator

Connection diagram

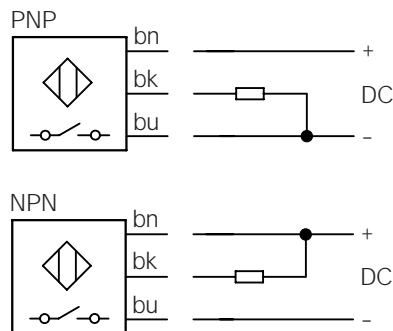

Wire colour	Assignment
bn brown	+ V DC
bk black	NO
bu blue	- V DC

Electrical and mechanical data

Operating voltage U_b	10 ... 30 V DC	Short-circuit protection (pulsed)	yes
Ripple U_{pp}	$\leq 20\%$ of U_b	Reverse polarity protection	yes
Voltage drop U_d (at $I_a = 50$ mA)	≤ 0.6 V max.	Power-up pulse suppression	yes
Power consumption (without load)	10 mA	Enclosure rating to EN 60529	IP 67
Continuous current I_a	≤ 100 mA	Shock and vibration stress	30 g, 11 ms 10 to 55 Hz, 1 mm
Time delay before availability t_v	≤ 10 ms	Ambient temperature T_a	- 25 ... + 70 °C
Hysteresis H typ.	10% of s_r	Housing material	Brass, nickel-plated, plastic
Repeatability R (U_b and T_a constant)	$\leq 2\%$	Tightening torque	0.8 Nm
Temperature drift	$\pm 10\%$ of s_r	Connection cable	PUR, 3 x 0.055 mm ²
EMC	to EN 60 947-5-2		

Selection table

Sensing range s_n mm	Installation in metal	Switching output	Output function	Switching frequency f in Hz	Connection	Type	Order number
0,6		PNP		2000	Cable 2 m	IM04-0B6PS-ZU1	6020145
0,6		NPN		2000	Cable 2 m	IM04-0B6NS-ZU1	6020146

Normally closed function available on request



Miniature series

Inductive proximity sensors

IM 05 series, sensing range 0.8 mm

DC 3-wire, miniature metal housing

Dimensions in mm

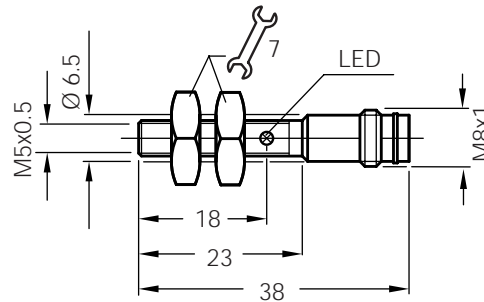
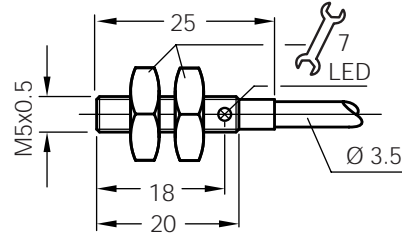

Features



- ▶ Can be installed flush
- ▶ PNP or NPN output
- ▶ Normally open function
- ▶ High switching frequency
- ▶ Short-circuit protection (pulsed)
- ▶ Robust brass housing, nickel-plated with fine thread M5 x 0.5 mm
- ▶ Cable or Connector
- ▶ Enclosure rating IP 67
- ▶ LED status indicator

Accessories

Round connectors

Connection diagram

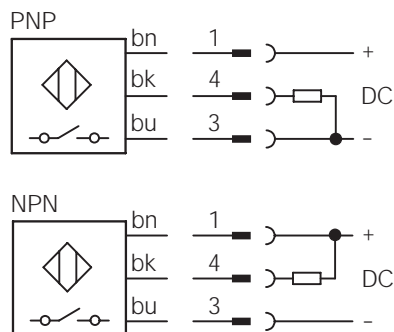

Wire colour	Contact	Assignment
bn brown	1	+ V DC
bk black	4	NO
bu blue	3	- V DC

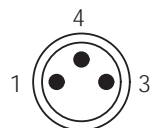

Electrical and mechanical data

Operating voltage U_b	10 ... 30 V DC	Short-circuit protection (pulsed)	yes
Ripple U_{pp}	$\leq 20\%$ of U_b	Reverse polarity protection	yes
Voltage drop U_d (at $I_a = 200$ mA)	≤ 2.0 V max.	Power-up pulse suppression	yes
Power consumption (without load)	10 mA	Enclosure rating to EN 60529	IP 67
Continuous current I_a	≤ 200 mA	Shock and vibration stress	30 g, 11 ms 10 to 55 Hz, 1 mm
Time delay before availability t_v	≤ 10 ms	Ambient temperature T_a	- 25 ... + 70 °C
Hysteresis H typ.	10% of s_r	Housing material	Brass, nickel-plated, plastic
Repeatability R (U_b and T_a constant)	$\leq 1,5\%$	Tightening torque	1.5 Nm
Temperature drift	$\pm 10\%$ of s_r	Connection cable	PVC, 3 x 0.14 mm ²
EMC	to EN 60 947-5-2		

Selection table

Sensing range s_n mm	Installation in metal	Switching output	Output function	Switching frequency f in Hz	Connection	Type	Order number
0.8		PNP		5000	Cable 2 m	IM05-0B8PS-ZW1	6011591
0.8		NPN		5000	Cable 2 m	IM05-0B8NS-ZW1	6020155
0.8		PNP		5000	Connector M8 x 1	IM05-0B8PS-ZT1	6020110
0.8		NPN		5000	Connector M8 x 1	IM05-0B8NS-ZT1	6020158

Normally closed function available on request

Inductive proximity sensors

IM 08 series, sensing range 1.5 / 2.5 mm

DC 3-wire, metal housing

Dimensions in mm



Standard series

Features



- ▶ Can be installed flush or non-flush in metal
- ▶ PNP or NPN output
- ▶ Normally open/ normally closed function
- ▶ High switching frequency
- ▶ Short-circuit protection (pulsed)
- ▶ Robust brass housing, nickel-plated with fine thread M8 x 1 mm
- ▶ Cable or connector
- ▶ Enclosure rating IP 67
- ▶ LED status indicator

Accessories

Round connectors

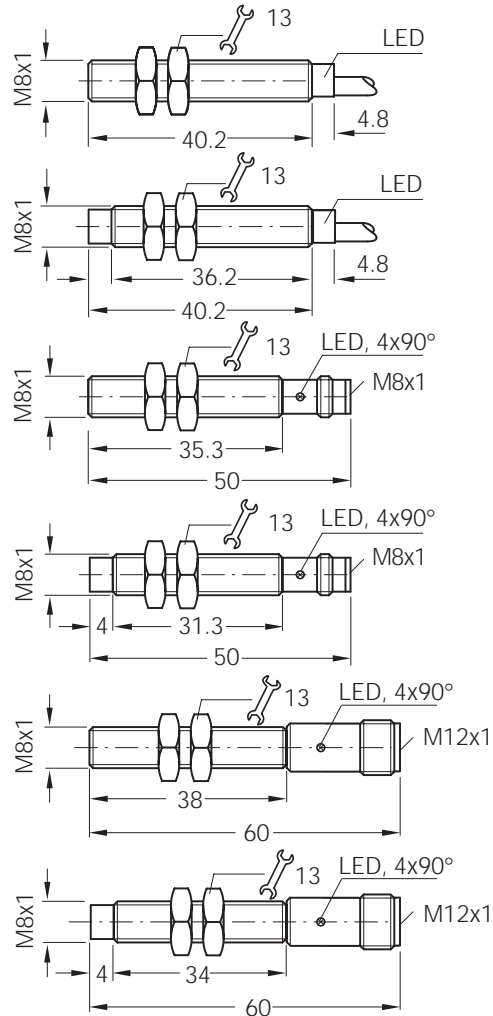

Connection diagram

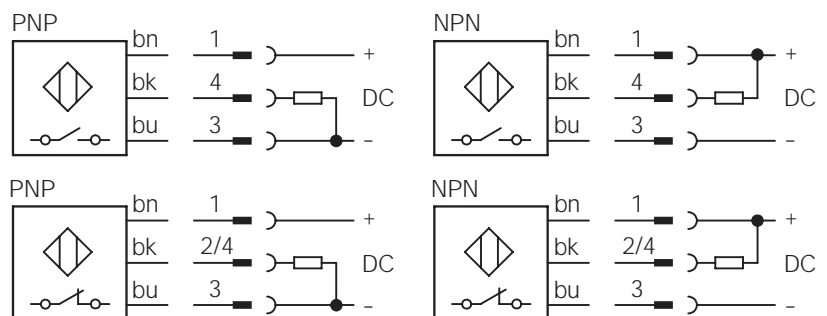

Wire colour	Contact M8	Contact M12	Assignment
bn brown	1	1	+ V DC
bk black	4	2/4	NC/NO
bu blue	3	3	- V DC

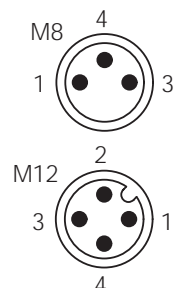

Electrical and mechanical data

Operating voltage U_b	10 ... 30 V DC	Short-circuit protection (pulsed)	yes
Ripple U_{pp}	$\leq 10\%$	Reverse polarity protection	yes
Voltage drop U_d (at I_a max.)	≤ 1.2 V	Power-up pulse suppression	yes
Power consumption (without load)	≤ 20 mA	Enclosure rating to EN 60529	IP 67
Continuous current I_a	≤ 200 mA	Shock and vibration stress	30 g, 11 ms 10 to 55 Hz, 1 mm
Time delay before availability t_v	≤ 100 ms	Ambient temperature T_a	- 25 ... + 70 °C
Hysteresis H	2% - 10% of s_r	Housing material	Brass, nickel-plated, plastic
Repeatability R (U_b and T_a constant)	$\leq 2\%$ of s_r	Tightening torque	4 Nm
Temperature drift	$\pm 10\%$ of s_r	Connection cable	PVC, 3 x 0.14 mm ²
EMC	to EN 60 947-5-2		

Selection table

Sensing range s_r mm	Installation in metal	Switching output	Output function	Switching frequency f in Hz	Connection	Type	Order number
1.5		PNP		3000	Cable 2 m	IM08-1B5PS-ZW1	6020215
1.5		NPN		3000	Cable 2 m	IM08-1B5NS-ZW1	6020216
1.5		PNP		3000	Cable 2 m	IM08-1B5PO-ZW1	6020217
1.5		NPN		3000	Cable 2 m	IM08-1B5NO-ZW1	6020218
1.5		PNP		3000	Connector M8 x 1 mm	IM08-1B5PS-ZT1	6020219
1.5		NPN		3000	Connector M8 x 1 mm	IM08-1B5NS-ZT1	6020220
1.5		PNP		3000	Connector M8 x 1 mm	IM08-1B5PO-ZT1	6020221
1.5		PNP		3000	Connector M12 x 1 mm	IM08-1B5PS-ZC1	6020223
1.5		NPN		3000	Connector M12 x 1 mm	IM08-1B5NS-ZC1	6020224
2.5		PNP		2500	Cable 2 m	IM08-2N5PS-ZW1	6020227
2.5		NPN		2500	Cable 2 m	IM08-2N5NS-ZW1	6020228
2.5		PNP		2500	Connector M8 x 1 mm	IM08-2N5PS-ZT1	6020231
2.5		NPN		2500	Connector M8 x 1 mm	IM08-2N5NS-ZT1	6020232
2.5		PNP		2500	Connector M12 x 1 mm	IM08-2N5PS-ZC1	6020235
2.5		NPN		2500	Connector M12 x 1 mm	IM08-2N5NS-ZC1	6020236

Inductive proximity sensors

IM 08 series, sensing range 1.5 mm

DC 3-wire, metal housing

Dimensions in mm



Miniature series

Features



- ▶ Can be installed flush
- ▶ PNP or NPN output
- ▶ Normally open function
- ▶ High switching frequency
- ▶ Short-circuit protection (pulsed)
- ▶ Robust brass housing, nickel-plated with fine thread M8 x 1 mm
- ▶ Cable or Connector
- ▶ Enclosure rating IP 67
- ▶ LED status indicator

Accessories

Round connectors

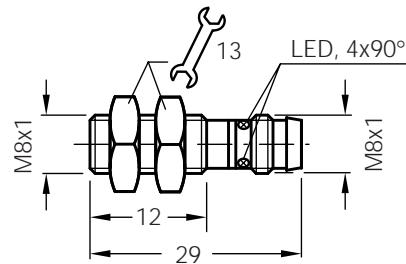
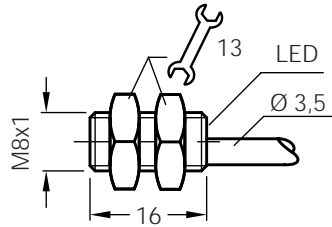

Connection diagram

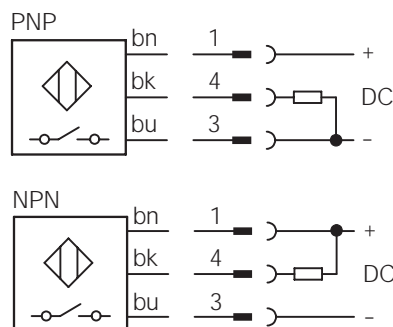

Wire colour	Contact	Assignment
bn brown	1	+ V DC
bk black	4	NO
bu blue	3	- V DC

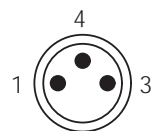

Electrical and mechanical data

Operating voltage U_b	10 ... 30 V DC	Short-circuit protection (pulsed)	yes
Ripple U_{pp}	$\leq 20\%$ of U_b	Reverse polarity protection	yes
Voltage drop U_d (at $I_a = 200$ mA)	≤ 2.0 V max.	Power-up pulse suppression	yes
Power consumption (without load)	≤ 10 mA	Enclosure rating to EN 60529	IP 67
Continuous current I_a	≤ 200 mA	Shock and vibration stress	30 g, 11 ms 10 to 55 Hz, 1 mm
Time delay before availability t_v	≤ 10 ms	Ambient temperature T_a	- 25 ... + 70 °C
Hysteresis H	10% of s_r	Housing material	Brass, nickel-plated, plastic
Repeatability R (U_b and T_a constant)	$\leq 5\%$ of s_r	Tightening torque	4 Nm
Temperature drift	$\pm 10\%$ of s_r	Connection cable	PVC, 3 x 0.14 mm ²
EMC	to EN 60 947-5-2		

Selection table

Sensing range s_n mm	Installation in metal	Switching output	Output function	Switching frequency f in Hz	Connection	Type	Order number
1.5		PNP		5000	Cable 2 m	IM08-1B5PS-ZWK	6020111
1.5		NPN		5000	Cable 2 m	IM08-1B5NS-ZWK	6020173
1.5		PNP		5000	Connector M8 x 1 mm	IM08-1B5PS-ZTK	6020112
1.5		NPN		5000	Connector M8 x 1 mm	IM08-1B5NS-ZTK	6020176

Normally closed function available on request



Advanced series

Inductive proximity sensors

IM 08 series, sensing range 2 / 4 mm

DC 3-wire, metal housing

Dimensions in mm

Features



- ▶ Enhanced sensing range
- ▶ Can be installed flush or non-flush in metal
- ▶ PNP or NPN output
- ▶ Normally open/ normally closed function
- ▶ High switching frequency
- ▶ Short-circuit protection (pulsed)
- ▶ Robust brass housing, nickel-plated with fine thread M8 x 1 mm
- ▶ Cable or connector
- ▶ Enclosure rating IP 67
- ▶ LED status indicator

Accessories

Round connectors

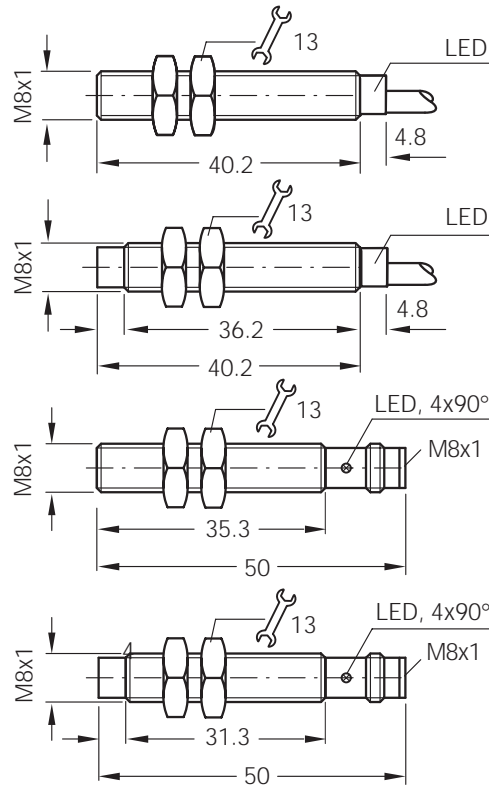

Connection diagram

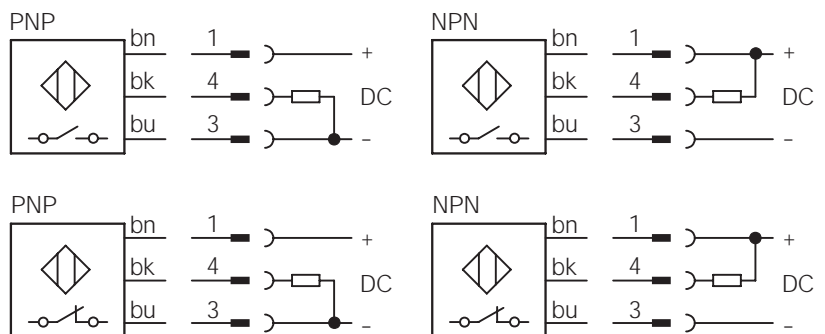

Wire colour	Contact	Assignment
bn brown	1	+ V DC
bk black	4	NC/NO
bu blue	3	- V DC

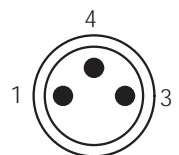

Electrical and mechanical data

Operating voltage U_b	10 ... 30 V DC	Short-circuit protection (pulsed)	yes
Ripple U_{pp}	$\leq 10\%$ of U_b	Reverse polarity protection	yes
Voltage drop U_d (at I_a max.)	≤ 1.2 V	Power-up pulse suppression	yes
Power consumption (without load)	≤ 20 mA	Enclosure rating to EN 60529	IP 67
Continuous current I_a	≤ 200 mA	Shock and vibration stress	30 g, 11 ms 10 to 55 Hz, 1 mm
Time delay before availability t_v	≤ 100 ms	Ambient temperature T_a	- 25 ... + 70 °C
Hysteresis H	2% - 15% of s_r	Housing material	Brass, nickel-plated, plastic
Repeatability R (U_b and T_a constant)	$\leq 5\%$ of s_r	Tightening torque	4 Nm
Temperature drift	$\pm 10\%$ of s_r	Connection cable	PVC, 3 x 0.14 mm ²
EMC	to EN 60 947-5-2		

Selection table

Sensing range s_n mm	Installation in metal	Switching output	Output function	Switching frequency f in Hz	Connection	Type	Order number
2		PNP		3000	Cable 2 m	IM08-02BPS-ZW1	7900001
2		NPN		3000	Cable 2 m	IM08-02BNS-ZW1	7900002
2		PNP		3000	Cable 2 m	IM08-02BPO-ZW1	7900003
2		PNP		3000	Connector M8 x 1 mm	IM08-02BPS-ZT1	7900005
2		NPN		3000	Connector M8 x 1 mm	IM08-02BNS-ZT1	7900006
2		PNP		3000	Connector M8 x 1 mm	IM08-02BPO-ZT1	7900007
2		NPN		3000	Connector M8 x 1 mm	IM08-02BNO-ZT1	7900008
4		PNP		3000	Cable 2 m	IM08-04NPS-ZW1	7900009
4		NPN		3000	Cable 2 m	IM08-04NNS-ZW1	7900010
4		PNP		3000	Cable 2 m	IM08-04NPO-ZW1	7900011
4		PNP		3000	Connector M8 x 1 mm	IM08-04NPS-ZT1	7900013
4		NPN		3000	Connector M8 x 1 mm	IM08-04NNS-ZT1	7900014
4		PNP		3000	Connector M8 x 1 mm	IM08-04NPO-ZT1	7900015
4		NPN		3000	Connector M8 x 1 mm	IM08-04NNO-ZT1	7900016

Inductive proximity sensors

IM 12 series, sensing range 2 / 4 mm

DC 3-wire, metal housing

Dimensions in mm



Standard series

Features



- ▶ Can be installed flush or non-flush in metal
- ▶ PNP or NPN output
- ▶ Normally open/ normally closed function
- ▶ Short-circuit protection (pulsed)
- ▶ Robust brass housing, nickel-plated with fine thread M12 x 1 mm
- ▶ Cable or connector
- ▶ Enclosure rating IP 67
- ▶ LED status indicator

Accessories

Round connectors
Mounting bracket

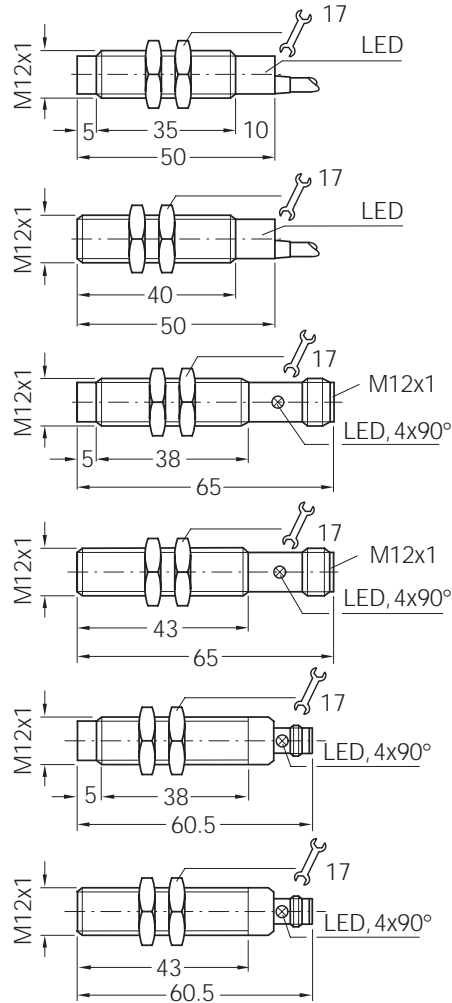

Connection diagram

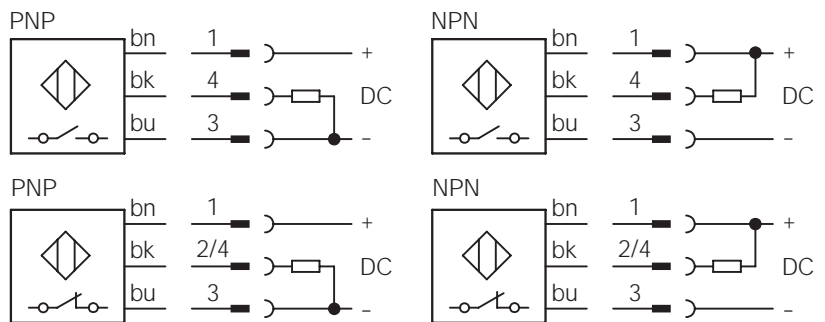

Wire colour	Contact M8	Contact M12	Assignment
bn brown	1	1	+ V DC
bk black	4	2/4	NC/NO
bu blue	3	3	- V DC

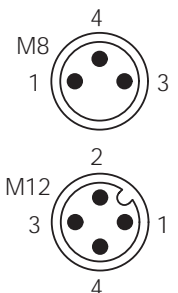

Electrical and mechanical data

Operating voltage U_b	10 ... 30 V DC	Short-circuit protection (pulsed)	yes
Ripple U_{pp}	$\leq 10\%$	Reverse polarity protection	yes
Voltage drop U_d (at I_a max.)	≤ 1.2 V	Power-up pulse suppression	yes
Power consumption (without load)	≤ 20 mA	Enclosure rating to EN 60529	IP 67
Continuous current I_a	≤ 200 mA	Shock and vibration stress	30 g, 11 ms 10 to 55 Hz, 1 mm
Time delay before availability t_v	≤ 100 ms	Ambient temperature T_a	- 25 ... + 70 °C
Hysteresis H	2% - 10% of s_r	Housing material	Brass, nickel-plated, plastic
Repeatability R (U_b and T_a constant)	$\leq 2\%$ of s_r	Tightening torque	10 Nm
Temperature drift	$\pm 10\%$ of s_r	Connection cable	PVC, 3 x 0.22 mm ²
EMC	to prEN 60 947-5-2		

Selection table

Sensing range s_n mm	Installation in metal	Switching output	Output function	Switching frequency f in Hz	Connection	Type	Order number
2		PNP		2000	Cable 2 m	IM12-02BPS-ZW1	6011963
2		NPN		2000	Cable 2 m	IM12-02BNS-ZW1	6011964
2		PNP		2000	Cable 2 m	IM12-02BPO-ZW1	6011965
2		NPN		2000	Cable 2 m	IM12-02BNO-ZW1	6011966
2		PNP		2000	Connector M8 x 1 mm	IM12-02BPS-ZT1	6011967
2		NPN		2000	Connector M8 x 1 mm	IM12-02BNS-ZT1	6011968
2		PNP		2000	Connector M12 x 1 mm	IM12-02BPS-ZC1	6011971
2		NPN		2000	Connector M12 x 1 mm	IM12-02BNS-ZC1	6011972
2		PNP		2000	Connector M12 x 1 mm	IM12-02BPO-ZC1	6011973
2		NPN		2000	Connector M12 x 1 mm	IM12-02BNO-ZC1	6011974
4		PNP		2000	Cable 2 m	IM12-04NPS-ZW1	6011975
4		NPN		2000	Cable 2 m	IM12-04NNS-ZW1	6011976
4		PNP		2000	Cable 2 m	IM12-04NPO-ZW1	6011977
4		PNP		2000	Connector M8 x 1 mm	IM12-04NPS-ZT1	6011979
4		NPN		2000	Connector M8 x 1 mm	IM12-04NNS-ZT1	6011980
4		PNP		2000	Connector M12 x 1 mm	IM12-04NPS-ZC1	6011983
4		NPN		2000	Connector M12 x 1 mm	IM12-04NNS-ZC1	6011984
4		PNP		2000	Connector M12 x 1 mm	IM12-04NPO-ZC1	6011985

Inductive proximity sensors

IM 12 series, sensing range 2 / 4 mm

DC 3-wire, metal housing

Dimensions in mm



Short version

Features



- ▶ Can be installed flush or non-flush in metal
- ▶ PNP or NPN output
- ▶ Normally open function
- ▶ High switching frequency
- ▶ Short-circuit protection (pulsed)
- ▶ Robust brass housing, nickel-plated with fine thread M12 x 1 mm
- ▶ Cable or connector
- ▶ Enclosure rating IP 67
- ▶ LED status indicator

Accessories

Round connectors
Mounting bracket

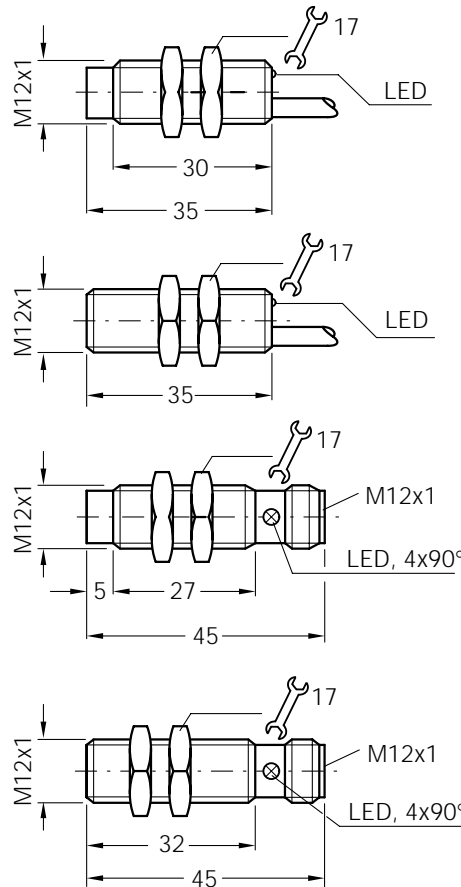

Connection diagram

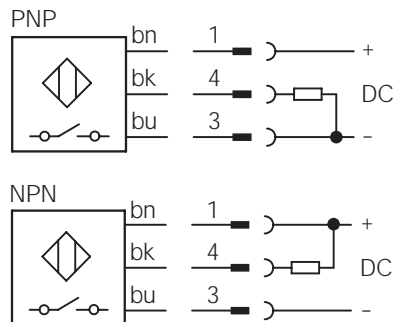



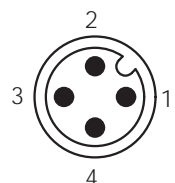













Wire colour	Contact	Assignment
bn brown	1	+ V DC
bk black	4	NO
bu blue	3	- V DC



Electrical and mechanical data

Operating voltage U_b	10 ... 30 V DC	Wire-break protection	yes
Ripple U_{pp}	$\leq 10\%$ of U_b	Short-circuit protection (pulsed)	yes
Voltage drop U_d (at I_a max.)	≤ 1.5 V	Reverse polarity protection	yes
Power consumption (without load)	≤ 10 mA	Power-up pulse protection	yes
Continuous current I_a	≤ 300 mA	Enclosure rating to EN 60529	IP 67
Time delay before availability t_v	≤ 2 ms	Shock and vibration stress	30 g, 11 ms 10 to 55 Hz, 1 mm
Hysteresis H	1% - 10% of s_r	Ambient temperature T_a	- 25 ... + 75 °C
Repeatability R (U_b and T_a constant)	$\leq 1\%$ of s_r	Housing material	Brass, nickel-plated, plastic
Temperature drift	$\pm 10\%$ of s_r	Tightening torque	7.0 Nm
EMC	to EN 60 947-5-2	Connection cable	PUR-PVC, 3 x 0.25 mm ²

Selection table

Sensing range s_n mm	Installation in metal	Switching output	Output function	Switching frequency f in Hz	Connection	Type	Order number
2		PNP		2000	Cable 2 m	IM12-02BPS-ZUK	1017426
2		NPN		2000	Cable 2 m	IM12-02BNS-ZUK	1017438
2		PNP		2000	Connector M12 x 1 mm	IM12-02BPS-ZCK	1017428
2		NPN		2000	Connector M12 x 1 mm	IM12-02BNS-ZCK	1017440
4		PNP		2000	Cable 2 m	IM12-04NPS-ZUK	1017427
4		NPN		2000	Cable 2 m	IM12-04NNS-ZUK	1017439
4		PNP		2000	Connector M12 x 1 mm	IM12-04NPS-ZCK	1017429
4		NPN		2000	Connector M12 x 1 mm	IM12-04NNS-ZCK	1017441

Inductive proximity sensors

IM 12 series, sensing range 4 / 8 mm

DC 3-wire, metal housing

Dimensions in mm



Advanced series

Features



- ▶ Enhanced sensing range
- ▶ Can be installed flush or non-flush in metal
- ▶ PNP or NPN output
- ▶ Normally open/ normally closed function
- ▶ High switching frequency
- ▶ Short-circuit protection (pulsed)
- ▶ Robust brass housing, nickel-plated with fine thread M12 x 1 mm
- ▶ Cable or connector
- ▶ Enclosure rating IP 67
- ▶ LED status indicator

Accessories

Round connectors
Mounting bracket

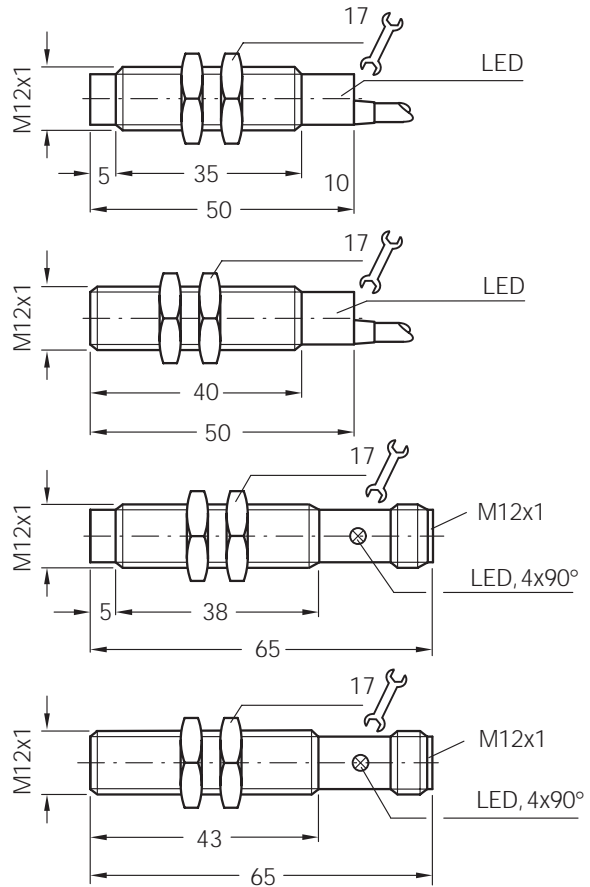

Connection diagram

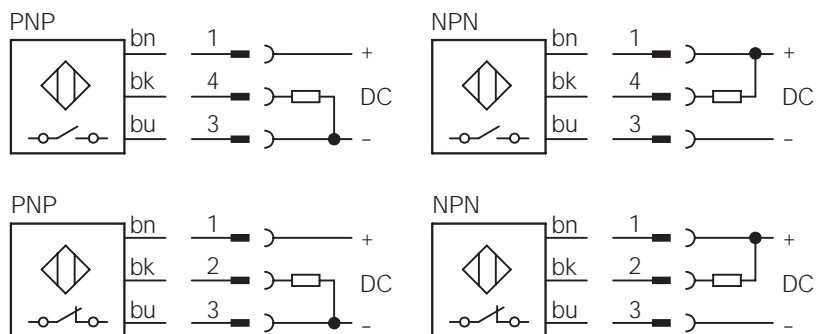

Wire colour	Contact	Assignment
bn	brown	1 + V DC
bk	black	2/4 NC/NO
bu	blue	3 - V DC

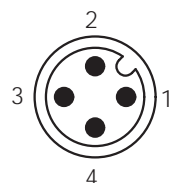

Electrical and mechanical data

Operating voltage U_b	10 ... 30 V DC	Short-circuit protection (pulsed)	yes
Ripple U_{pp}	$\leq 10\%$ of U_b	Reverse polarity protection	yes
Voltage drop U_d (at I_a max.)	≤ 1.2 V	Power-up pulse suppression	yes
Power consumption (without load)	≤ 10 mA	Enclosure rating to EN 60529	IP 67
Continuous current I_a	≤ 200 mA	Shock and vibration stress	30 g, 11 ms 10 to 55 Hz, 1 mm
Time delay before availability t_v	≤ 100 ms	Ambient temperature T_a	- 25 ... + 70 °C
Hysteresis H	1% - 15% of s_r	Housing material	Brass, nickel-plated, plastic
Repeatability R (U_b and T_a constant)	$\leq 5\%$ of s_r	Tightening torque	10 Nm
Temperature drift	$\pm 10\%$ of s_r	Connection cable	PVC, 3 x 0.22 mm ²
EMC	to EN 60 947-5-2		

Selection table

Sensing range s_n mm	Installation in metal	Switching output	Output function	Switching frequency f in Hz	Connection	Type	Order number
4		PNP		1000	Cable 2 m	IM12-04BPS-ZW1	7900033
4		NPN		1000	Cable 2 m	IM12-04BNS-ZW1	7900034
4		PNP		1000	Cable 2 m	IM12-04BPO-ZW1	7900035
4		PNP		1000	Connector M12 x 1 mm	IM12-04BPS-ZC1	7900037
4		NPN		1000	Connector M12 x 1 mm	IM12-04BNS-ZC1	7900038
4		PNP		1000	Connector M12 x 1 mm	IM12-04BPO-ZC1	7900039
8		PNP		1000	Cable 2 m	IM12-08NPS-ZW1	7900041
8		NPN		1000	Cable 2 m	IM12-08NNS-ZW1	7900042
8		PNP		1000	Cable 2 m	IM12-08NPO-ZW1	7900043
8		NPN		1000	Cable 2 m	IM12-08NNO-ZW1	7900044
8		PNP		1000	Connector M12 x 1 mm	IM12-08NPS-ZC1	7900045
8		NPN		1000	Connector M12 x 1 mm	IM12-08NNS-ZC1	7900046
8		PNP		1000	Connector M12 x 1 mm	IM12-08NPO-ZC1	7900047

* see installation notes



Inductive proximity sensors

IM 12 series, sensing range 2 / 4 mm

DC 4-wire, metal housing

Dimensions in mm

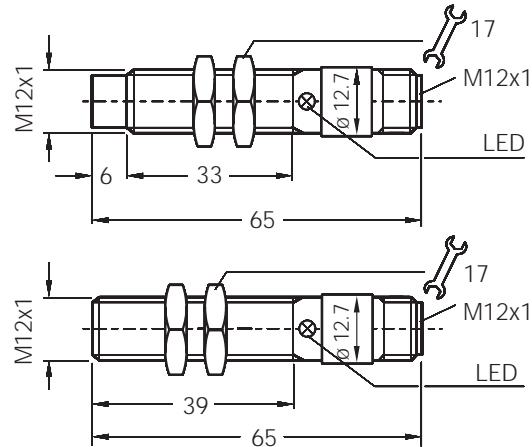

For harsh environment

Features



- ▶ For harsh environment, resistant to most cutting oils
- ▶ Enclosure rating IP 68
- ▶ Can be installed flush or non-flush in metal
- ▶ PNP or NPN output
- ▶ Complementary output function
- ▶ Short-circuit protection (pulsed)
- ▶ Robust brass housing, nickel-plated with fine thread M12 x 1 mm
- ▶ Internal enclosure housing in technopolymer
- ▶ Connector
- ▶ LED status indicator (NO function)

Accessories

- Round connectors
- Mounting bracket

Connection diagram

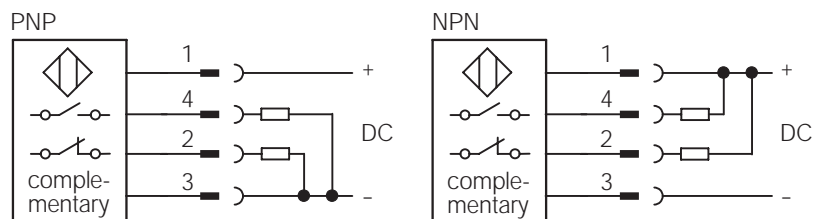



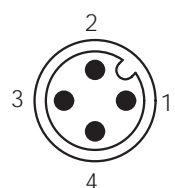





Wire colour	Contact	Assignment
bn brown	1	+ V DC
wh white	2	NC
bu blue	3	- V DC
bk black	4	NO



Electrical and mechanical data

Operating voltage U_b	10 ... 30 V DC	Short-circuit protection (pulsed)	yes
Ripple U_{pp}	$\leq 10\%$	Reverse polarity protection	yes
Voltage drop U_d (at I_a max.)	≤ 1.2 V	Power-up pulse suppression	yes
Power consumption (without load)	≤ 20 mA	Enclosure rating	IP 68
Continuous current I_a	≤ 100 mA	Shock and vibration stress	30 g, 11 ms 10 to 55 Hz, 1 mm
Time delay before availability t_v	≤ 100 ms	Ambient temperature T_a	- 25 ... + 70 °C
Hysteresis H	2% - 10% of s_r	Housing material	Brass, nickel-plated, plastic
Repeatability R (U_b and T_a constant)	$\leq 5\%$ of s_r	Tightening torque	10 Nm
Temperature drift EMC	$\pm 10\%$ of s_r to EN 60 947-5-2		

Selection table

Sensing range s_n mm	Installation in metal	Switching output	Output function	Switching frequency f in Hz	Connection	Type	Order number
2		PNP	 complementary	2000	Connector M12 x 1 mm	IM12-02BPP-ZC1	7902923
2		NPN	 complementary	2000	Connector M12 x 1 mm	IM12-02BNP-ZC1	7902924
4		PNP	 complementary	2000	Connector M12 x 1 mm	IM12-04NPP-ZC1	7902925
4		NPN	 complementary	2000	Connector M12 x 1 mm	IM12-04NNP-ZC1	7902926



Multitalents

Features



- ▶ Free configurable output functions in one sensor
PNP / NO, PNP / NC
NPN / NO, NPN / NC
- ▶ Can be installed flush or non-flush in metal
- ▶ Short-circuit protection
- ▶ Robust brass housing, nickel-plated with fine thread M12 x 1 mm
- ▶ Cable or connector
- ▶ Enclosure rating IP 67
- ▶ LED status indicator (NO function)

Accessories

Round connectors
Mounting bracket

Inductive proximity sensors

IM 12 series, sensing range 2 / 4 mm

DC 4-wire, metal housing

Dimensions in mm

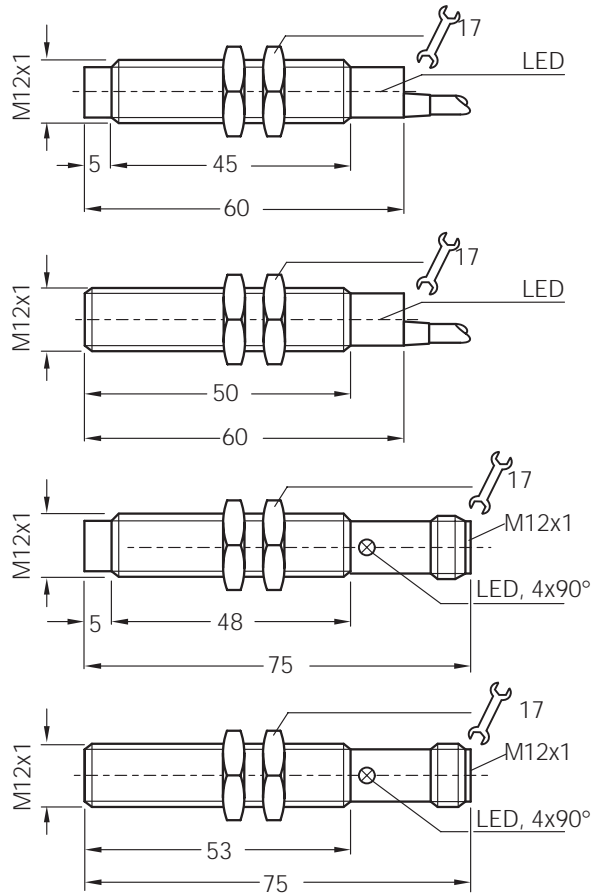

Connection diagram

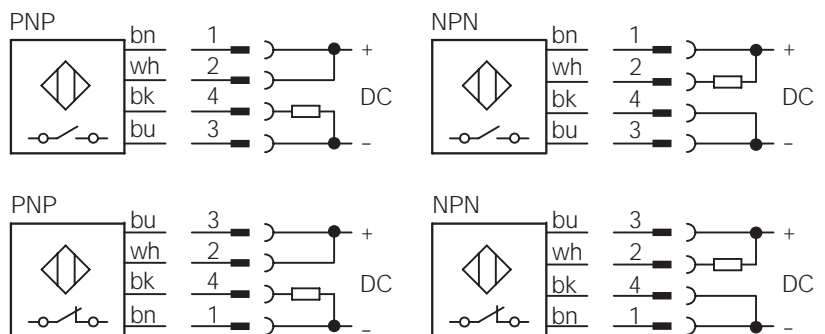



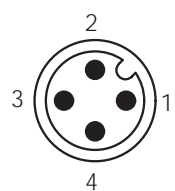





Wire colour		Contact	configurable output function			
			PNP		NPN	
bn	brown	1	+V DC	-V DC	+V DC	-V DC
wh	white	2	+V DC	+V DC	NO	NC
bu	blue	3	-V DC	+V DC	-V DC	+V DC
bk	black	4	NO	NC	-V DC	-V DC



Electrical and mechanical data

Operating voltage U_b	10 ... 30 V DC	Short-circuit protection	yes
Ripple U_{pp}	$\leq 10\%$	Reverse polarity protection	yes
Voltage drop U_d (at I_a max.)	≤ 1.2 V	Power-up pulse suppression	yes
Power consumption (without load)	≤ 30 mA	Enclosure rating to EN 60529	IP 67
Continuous current I_a	≤ 100 mA	Shock and vibration stress	30 g, 11 ms 10 to 55 Hz, 1 mm
Time delay before availability t_v	≤ 250 ms	Ambient temperature T_a	- 25 ... + 70 °C
Hysteresis H	2% - 10% of s_r	Housing material	Brass, nickel-plated, plastic
Repeatability R (U_b and T_a constant)	$\leq 5\%$ of s_r	Tightening torque	15 Nm
Temperature drift	$\pm 10\%$ of s_r	Connection cable	PVC, 4 x 0.22 mm ²
EMC	to EN 60 947-5-2		

Selection table

Sensing range s_n mm	Installation in metal	Switching output	Output function	Switching frequency f in Hz	Connection	Type	Order number
2		PNP/NPN config.		1000	Cable 2 m	IM12-02BCP-ZW1	7902927
2		PNP/NPN config.		1000	Connector M12 x 1 mm	IM12-02BCP-ZC1	7902928
4		PNP/NPN config.		1000	Cable 2 m	IM12-04NCP-ZW1	7902929
4		PNP/NPN config.		1000	Connector M12 x 1 mm	IM12-04NCP-ZC1	7902930

Inductive proximity sensors

IM 18 series, sensing range 5 / 8 mm

DC 3-wire, metal housing

Dimensions in mm



Standard series

Features



- ▶ Can be installed flush or non-flush in metal
- ▶ PNP or NPN output
- ▶ Normally open/ normally closed function
- ▶ Short-circuit protection (pulsed)
- ▶ Robust brass housing, nickel-plated with fine thread M18 x 1 mm
- ▶ Cable or connector
- ▶ Enclosure rating IP 67
- ▶ LED status indicator

Accessories

Round connectors
Mounting bracket

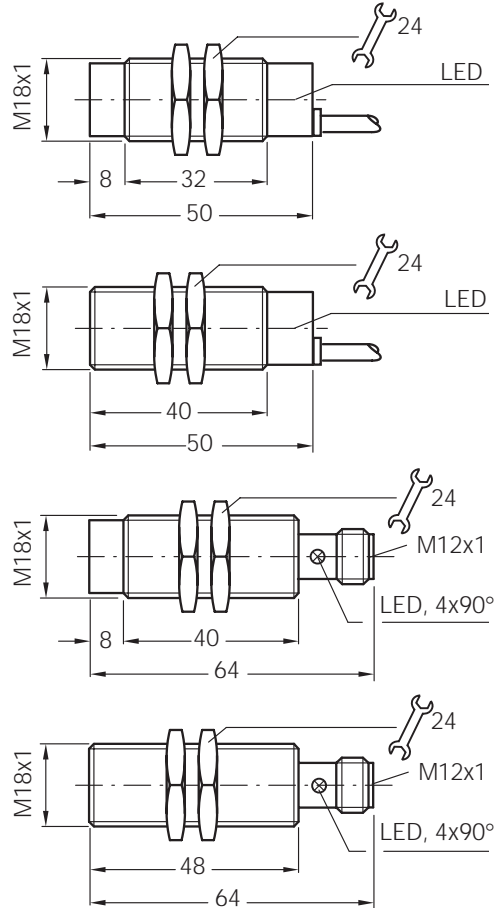

Connection diagram

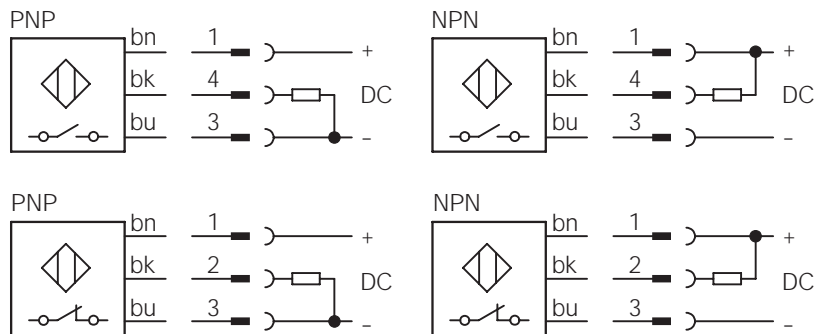



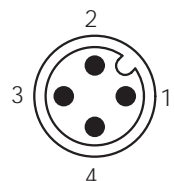





















Wire colour	Colour	Contact	Assignment
bn	brown	1	+ V DC
bk	black	2/4	NC/NO
bu	blue	3	- V DC



Electrical and mechanical data

Operating voltage U_b	10 ... 30 V DC	Short-circuit protection (pulsed)	yes
Ripple U_{pp}	$\leq 10\%$	Reverse polarity protection	yes
Voltage drop U_d (at I_a max.)	≤ 1 V	Power-up pulse suppression	yes
Power consumption (without load)	≤ 20 mA	Enclosure rating to EN 40050	IP 67
Continuous current I_a	≤ 400 mA	Shock and vibration stress	30 g, 11 ms 10 to 55 Hz, 1 mm
Time delay before availability t_v	≤ 100 ms	Ambient temperature T_a	- 25 ... + 70 °C
Hysteresis H	2% - 10% of s_r	Housing material	Brass, nickel-plated, plastic
Repeatability R (U_b and T_a constant)	$\leq 2\%$ of s_r	Tightening torque	30 Nm
Temperature drift	$\pm 10\%$ of s_r	Connection cable	PVC, 3 x 0.34 mm ²
EMC	to EN 60 947-5-2		

Selection table

Sensing range s_n mm	Installation in metal	Switching output	Switching function	Switching frequency f in Hz	Connection	Type	Order number
5		PNP		600	Cable 2 m	IM18-05BPS-ZW1	6011987
5		NPN		600	Cable 2 m	IM18-05BNS-ZW1	6011988
5		PNP		600	Cable 2 m	IM18-05BPO-ZW1	6011989
5		PNP		600	Connector M12 x 1 mm	IM18-05BPS-ZC1	6011991
5		NPN		600	Connector M12 x 1 mm	IM18-05BNS-ZC1	6011992
5		PNP		600	Connector M12 x 1 mm	IM18-05BPO-ZC1	6011993
8		PNP		600	Cable 2 m	IM18-08NPS-ZW1	6011995
8		NPN		600	Cable 2 m	IM18-08NNS-ZW1	6011996
8		NPN		600	Cable 2 m	IM18-08NNO-ZW1	6011998
8		PNP		600	Connector M12 x 1 mm	IM18-08NPS-ZC1	6011999
8		NPN		600	Connector M12 x 1 mm	IM18-08NNS-ZC1	6012000
8		PNP		600	Connector M12 x 1 mm	IM18-08NPO-ZC1	6012001

Inductive proximity sensors

IM 18 series, sensing range 5 / 8 mm

DC 3-wire, metal housing

Dimensions in mm



Short version

Features



- ▶ Can be installed flush or non-flush in metal
- ▶ PNP or NPN output
- ▶ Normally open function
- ▶ Short-circuit protection (pulsed)
- ▶ Robust brass housing, nickel-plated with fine thread M18 x 1 mm
- ▶ Cable and connector
- ▶ Enclosure rating IP 67
- ▶ LED status indicator

Accessories

Round connectors
Mounting bracket

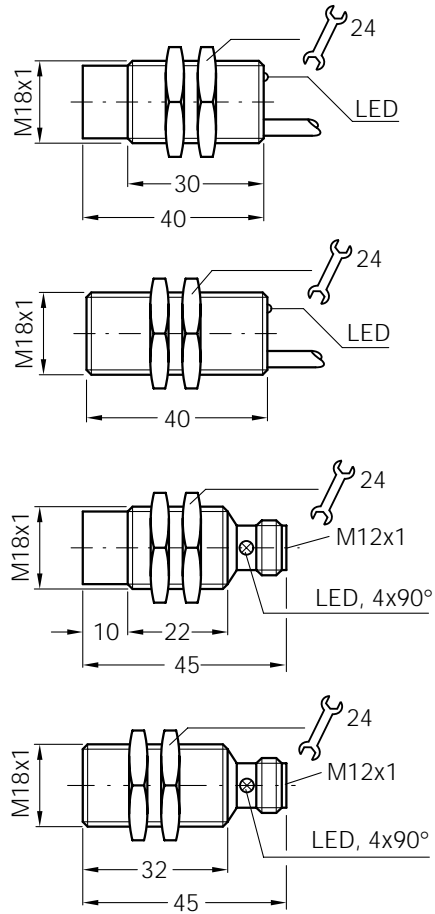

Connection diagram

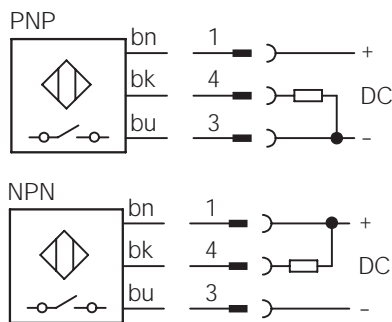



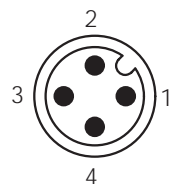













Wire colour	Contact	Assignment
bn	brown	1 + V DC
bk	black	4 NO
bu	blue	3 - V DC



Electrical and mechanical data

Operating voltage U_b	10 ... 30 V DC	Wire-break protection	yes
Ripple U_{pp}	$\leq 10\%$ of U_b	Short-circuit protection (pulsed)	yes
Voltage drop U_d (at I_a max.)	≤ 1.5 V	Reverse polarity protection	yes
Power consumption (without load)	≤ 10 mA	Power-up pulse suppression	yes
Continuous current I_a	≤ 300 mA	Enclosure rating to EN 60529	IP 67
Time delay before availability t_v	≤ 10 ms	Shock and vibration stress	30 g, 11 ms 10 to 55 Hz, 1 mm
Hysteresis H	2% - 10% of s_r	Ambient temperature T_a	- 25 ... + 75 °C
Repeatability R (U_b and T_a constant)	$\leq 2\%$ of s_r	Housing material	Brass, nickel-plated, plastic
Temperature drift	$\pm 10\%$ of s_r	Tightening torque	25 Nm
EMC	to EN 60 947-5-2	Connection cable	PUR-PVC, 3 x 0.25 mm ²

Selection table

Sensing range s_n mm	Installation in metal	Switching output	Switching function	Switching frequency f in Hz	Connection	Type	Order number
5		PNP		1000	Cable 2 m	IM18-05BPS-ZUK	1017430
5		NPN		1000	Cable 2 m	IM18-05BNS-ZUK	1017442
5		PNP		1000	Connector M12 x 1 mm	IM18-05BPS-ZCK	1017432
5		NPN		1000	Connector M12 x 1 mm	IM18-05BNS-ZCK	1017444
8		PNP		1000	Cable 2 m	IM18-08NPS-ZUK	1017431
8		NPN		1000	Cable 2 m	IM18-08NNS-ZUK	1017443
8		PNP		1000	Connector M12 x 1 mm	IM18-08NPS-ZCK	1017433
8		NPN		1000	Connector M12 x 1 mm	IM18-08NNS-ZCK	1017445



Advanced series

Inductive proximity sensors

IM 18 series, sensing range 8 / 12 mm

DC 3-wire, metal housing

Dimensions in mm

Features



- ▶ Enhanced sensing range
- ▶ Can be installed flush or non-flush in metal
- ▶ PNP or NPN output
- ▶ Normally open/ normally closed function
- ▶ High switching frequency
- ▶ Short-circuit protection (pulsed)
- ▶ Robust brass housing, nickel-plated with fine thread M18 x 1 mm
- ▶ Cable and connector
- ▶ Enclosure rating IP 67
- ▶ LED status indicator

Accessories

Round connectors
Mounting bracket

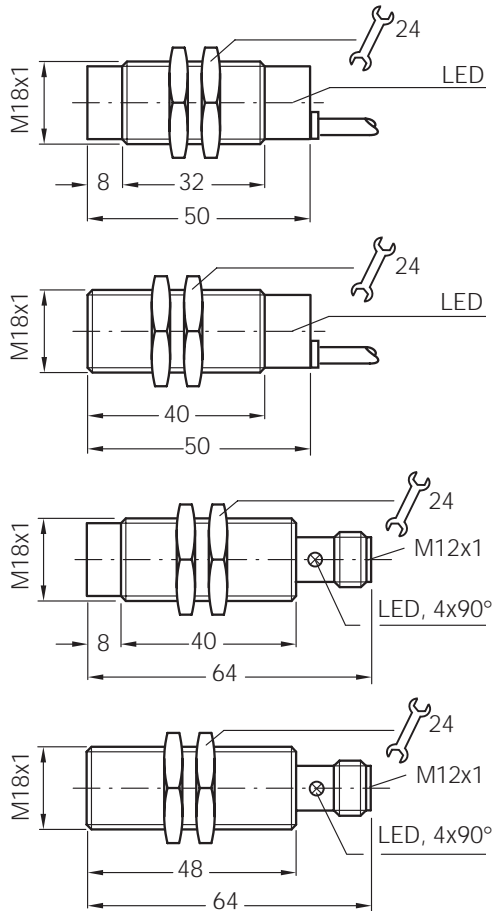

Connection diagram

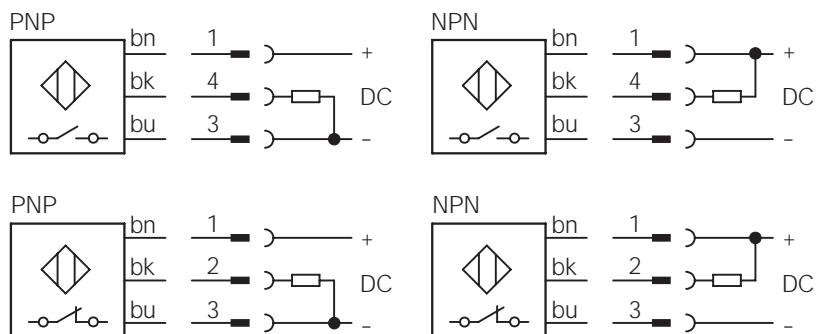



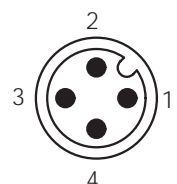

















Wire colour	Contact	Assignment
bn brown	1	+ V DC
bk black	2/4	NC/NO
bu blue	3	- V DC



Electrical and mechanical data

Operating voltage U_b	10 ... 30 V DC	Short-circuit protection (pulsed)	yes
Ripple U_{pp}	$\leq 10\%$ of U_b	Reverse polarity protection	yes
Voltage drop U_d (at I_a max.)	≤ 1 V	Power-up pulse suppression	yes
Power consumption (without load)	≤ 10 mA	Enclosure rating to EN 60529	IP 67
Continuous current I_a	≤ 400 mA	Shock and vibration stress	30 g, 11 ms 10 to 55 Hz, 1 mm
Time delay before availability t_v	≤ 100 ms	Ambient temperature T_a	- 25 ... + 70 °C
Hysteresis H	2% - 15% of s_r	Housing material	Brass, nickel-plated, plastic
Repeatability R (U_b and T_a constant)	$\leq 5\%$ of s_r	Tightening torque	30 Nm
Temperature drift	$\pm 10\%$ of s_r	Connection cable	PVC, 3 x 0.34 mm ²
EMC	to EN 60 947-5-2		

Selection table

Sensing range s_n mm	Installation in metal	Switching output	Output function	Switching frequency f in Hz	Connection	Type	Order number
8		PNP		300	Cable 2 m	IM18-08BPS-ZW1	7900081
8		NPN		300	Cable 2 m	IM18-08BNS-ZW1	7900082
8		PNP		300	Connector M12 x 1 mm	IM18-08BPS-ZC1	7900085
8		NPN		300	Connector M12 x 1 mm	IM18-08BNS-ZC1	7900086
8		PNP		300	Connector M12 x 1 mm	IM18-08BPO-ZC1	7900087
12		PNP		300	Cable 2 m	IM18-12NPS-ZW1	7900093
12		NPN		300	Cable 2 m	IM18-12NNS-ZW1	7900094
12		PNP		300	Connector M12 x 1 mm	IM18-12NPS-ZC1	7900097
12		NPN		300	Connector M12 x 1 mm	IM18-12NNS-ZC1	7900098
12		PNP		300	Connector M12 x 1 mm	IM18-12NPO-ZC1	7900099

* see installation notes



Inductive proximity sensors

IM 18 series, sensing range 5 / 8 mm

DC 4-wire, metal housing

Dimensions in mm

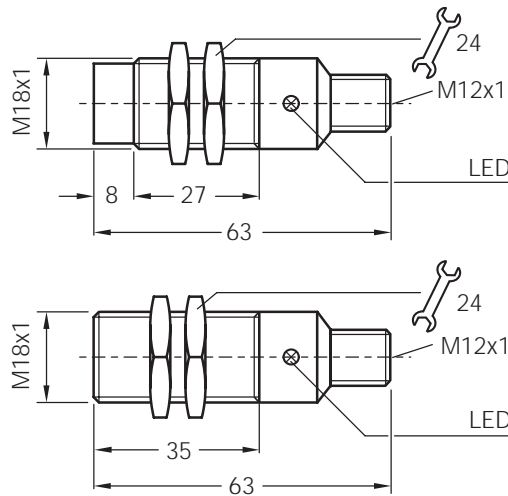

For harsh environment

Features



- ▶ For harsh environment, resistant to most cutting oils
- ▶ Enclosure rating IP 68
- ▶ Can be installed flush or non-flush in metal
- ▶ PNP or NPN output
- ▶ Complementary output function
- ▶ Short-circuit protection (pulsed)
- ▶ Robust brass housing, nickel-plated with fine thread M12 x 1 mm
- ▶ Internal enclosure housing in technopolymer
- ▶ Connector
- ▶ LED status indicator (NO function)

Accessories

- Round connectors
- Mounting bracket

Connection diagram

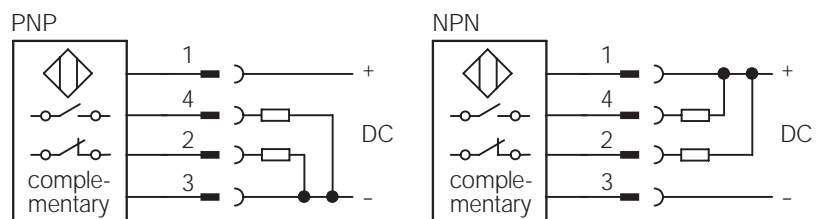



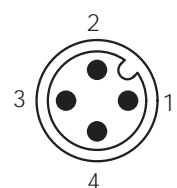





Wire colour	Contact	Assignment
bn brown	1	+ V DC
wh white	2	NC
bu blue	3	- V DC
bk black	4	NO



Electrical and mechanical data

Operating voltage U_b	10 ... 30 V DC	Short-circuit protection (pulsed)	yes
Ripple U_{pp}	$\leq 10\%$	Reverse polarity protection	yes
Voltage drop U_d (at I_a max.)	≤ 0.8 V	Power-up pulse suppression	yes
Power consumption (without load)	≤ 20 mA	Enclosure rating	IP 68
Continuous current I_a	≤ 400 mA	Shock and vibration stress	30 g, 11 ms 10 to 55 Hz, 1 mm
Time delay before availability t_v	≤ 100 ms	Ambient temperature T_a	- 25 ... + 70 °C
Hysteresis H	2% - 10% of s_r	Housing material	Brass, nickel-plated, plastic
Repeatability R (U_b and T_a constant)	$\leq 5\%$ of s_r	Tightening torque	40 Nm
Temperature drift EMC	$\pm 10\%$ of s_r to EN 60 947-5-2		

Selection table

Sensing range s_n mm	Installation in metal	Switching output	Output function	Switching frequency f in Hz	Connection	Type	Order number
5		PNP	 complementary	1000	Connector M12 x 1 mm	IM18-05BPP-ZC1	7902931
5		NPN	 complementary	1000	Connector M12 x 1 mm	IM18-05BNP-ZC1	7902932
8		PNP	 complementary	1000	Connector M12 x 1 mm	IM18-08NPP-ZC1	7902933
8		NPN	 complementary	1000	Connector M12 x 1 mm	IM18-08NNP-ZC1	7902934

Inductive proximity sensors

IM 18 series, sensing range 5 / 8 mm

DC 4-wire, metal housing

Dimensions in mm



Multitalents

Features



- ▶ Free configurable output functions in one sensor
PNP / NO, PNP / NC
NPN / NO, NPN / NC
- ▶ Can be installed flush or non-flush in metal
- ▶ Short-circuit protection
- ▶ Robust brass housing, nickel-plated with fine thread M18 x 1 mm
- ▶ Cable or connector
- ▶ Enclosure rating IP 67
- ▶ LED status indicator (NO function)

Accessories

Round connectors
Mounting bracket

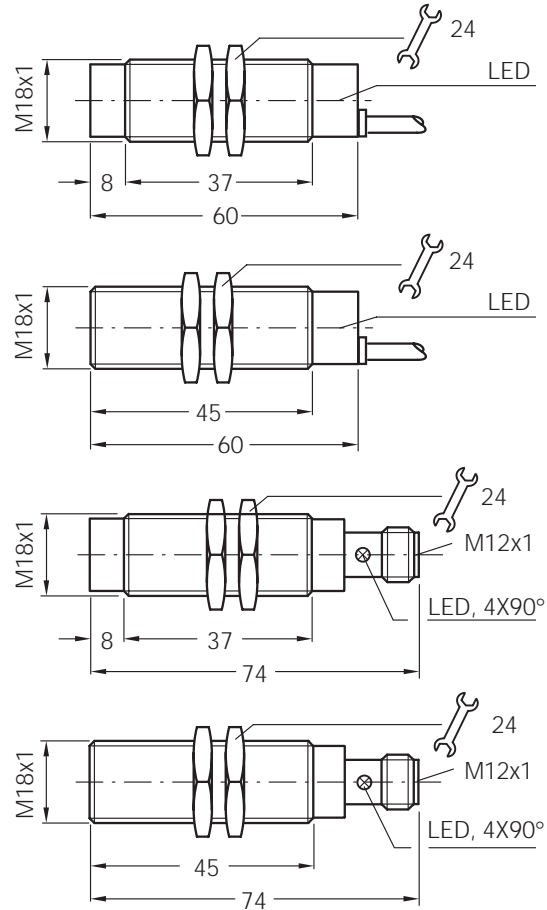

Connection diagram

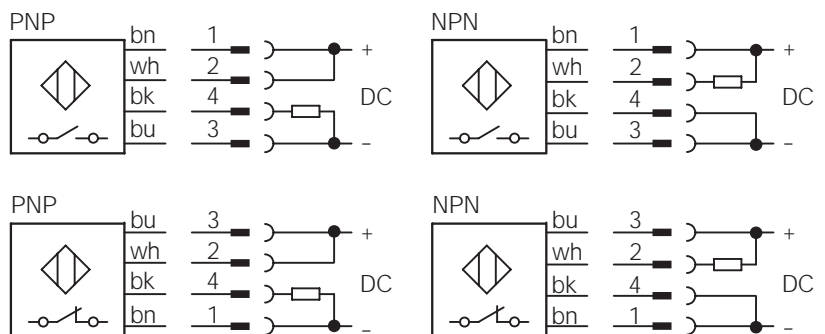



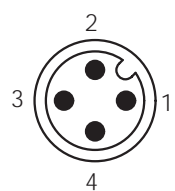





Wire colour		Contact	configurable output function			
			PNP		NPN	
			+V DC	-V DC	+V DC	-V DC
bn	brown	1	+V DC	-V DC	+V DC	-V DC
wh	white	2	+V DC	+V DC	NO	NC
bu	blue	3	-V DC	+V DC	-V DC	+V DC
bk	black	4	NO	NC	-V DC	-V DC



Electrical and mechanical data

Operating voltage U_b	10 ... 30 V DC	Short-circuit protection	yes
Ripple U_{pp}	$\leq 10\%$	Reverse polarity protection	yes
Voltage drop U_d (at I_a max.)	≤ 1.2 V	Power-up pulse suppression	yes
Power consumption (without load)	≤ 30 mA	Enclosure rating to EN 60529	IP 67
Continuous current I_a	≤ 100 mA	Shock and vibration stress	30 g, 11 ms 10 to 55 Hz, 1 mm
Time delay before availability t_v	≤ 200 ms	Ambient temperature T_a	- 25 ... + 70 °C
Hysteresis H	2% - 10% of s_r	Housing material	Brass, nickel-plated, plastic
Repeatability R (U_b and T_a constant)	$\leq 5\%$ of s_r	Tightening torque	40 Nm
Temperature drift	$\pm 10\%$ of s_r	Connection cable	PVC, 4 x 0.34 mm ²
EMC	to prEN 60 947-5-2		

Selection table

Sensing range s_n mm	Installation in metal	Switching output	Output function	Switching frequency f in Hz	Connection	Type	Order number
5		PNP/NPN config.		300	Cable 2 m	IM18-05BCP-ZW1	7902935
5		PNP/NPN config.		300	Connector M12 x 1 mm	IM18-05BCP-ZC1	7902936
8		PNP/NPN config.		300	Cable 2 m	IM18-08NCP-ZW1	7902937
8		PNP/NPN config.		300	Connector M12 x 1 mm	IM18-08NCP-ZC1	7902938

Inductive proximity sensors

IM 30 series, sensing range 10 / 15 mm

DC 3-wire, metal housing

Dimensions in mm



Standard series

Features



- ▶ Can be installed flush or non-flush in metal
- ▶ PNP or NPN output
- ▶ Normally open/ normally closed function
- ▶ High switching frequency
- ▶ Short-circuit protection (pulsed)
- ▶ Robust brass housing, nickel-plating with fine thread M30 x 1.5 mm
- ▶ Cable or connector
- ▶ Enclosure rating IP 67
- ▶ LED status indicator

Accessories

Round connectors
Mounting bracket

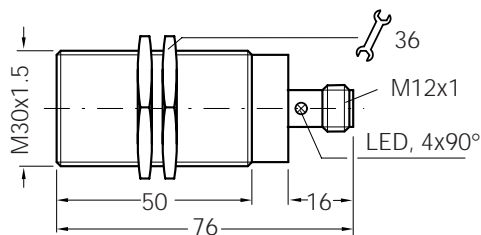
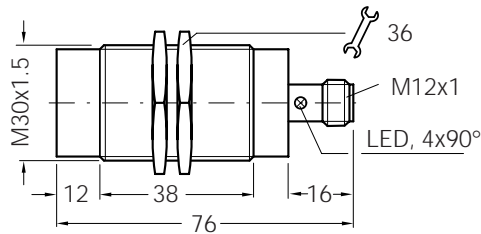
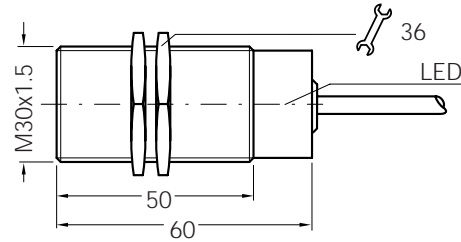
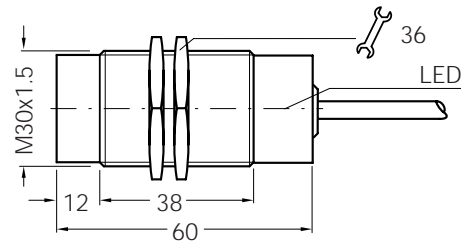

Connection diagram

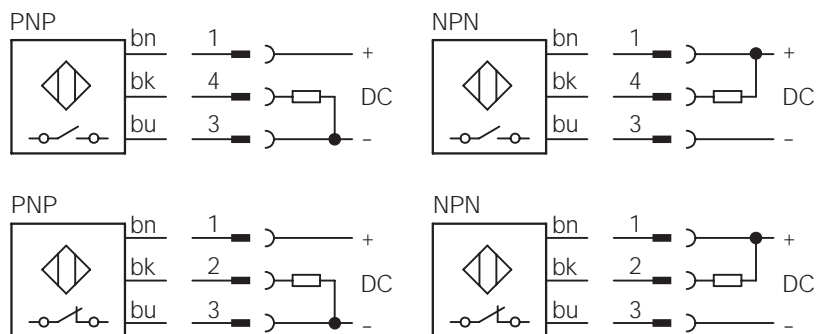



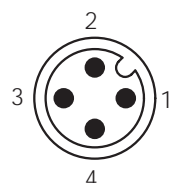

















Wire colour	Contact	Assignment
bn	brown	1 + V DC
bk	black	2/4 NC/NO
bu	blue	3 - V DC



Electrical and mechanical data

Operating voltage U_b	10 ... 30 V DC	Short-circuit protection (pulsed)	yes
Ripple U_{pp}	$\leq 10\%$	Reverse polarity protection	yes
Voltage drop U_d (at I_a max.)	≤ 1 V	Power-up pulse suppression	yes
Power consumption (without load)	≤ 20 mA	Enclosure rating to EN 60529	IP 67
Continuous current I_a	≤ 400 mA	Shock and vibration stress	30 g, 11 ms 10 to 55 Hz, 1 mm
Time delay before availability t_v	≤ 100 ms	Ambient temperature T_a	- 25 ... + 70 °C
Hysteresis H	2% - 10% of s_r	Housing material	Brass, nickel-plated, plastic
Repeatability R (U_b and T_a constant)	$\leq 2\%$ of s_r	Tightening torque	60 Nm
Temperature drift	$\pm 10\%$ of s_r	Connection cable	PVC, 3 x 0.5 mm ²
EMC	to EN 60 947-5-2		

Selection table

Sensing range s_n mm	Installation in metal	Switching output	Output function	Switching frequency f in Hz	Connection	Type	Order number
10		PNP		200	Cable 2 m	IM30-10BPS-ZW1	6020274
10		NPN		200	Cable 2 m	IM30-10BNS-ZW1	6020275
10		PNP		200	Connector M12 x 1 mm	IM30-10BPS-ZC1	6020278
10		NPN		200	Connector M12 x 1 mm	IM30-10BNS-ZC1	6020279
10		PNP		200	Connector M12 x 1 mm	IM30-10BPO-ZC1	6020280
15		PNP		200	Cable 2 m	IM30-15NPS-ZW1	6020282
15		NPN		200	Cable 2 m	IM30-15NNS-ZW1	6020283
15		PNP		200	Cable 2 m	IM30-15NPO-ZW1	6020284
15		PNP		200	Connector M12 x 1 mm	IM30-15NPS-ZC1	6020286
15		NPN		200	Connector M12 x 1 mm	IM30-15NNS-ZC1	6020287

Inductive proximity sensors

IM 30 series, sensing range 10 / 15 mm

DC 3-wire, metal housing

Dimensions in mm



Short version

Features



- ▶ Can be installed flush or non-flush in metal
- ▶ PNP or NPN output
- ▶ Normally open function
- ▶ Short-circuit protection (pulsed)
- ▶ Robust brass housing, nickel-plating with fine thread M30 x 1.5 mm
- ▶ Cable or connector
- ▶ Enclosure rating IP 67
- ▶ LED status indicator

Accessories

Round connectors
Mounting bracket

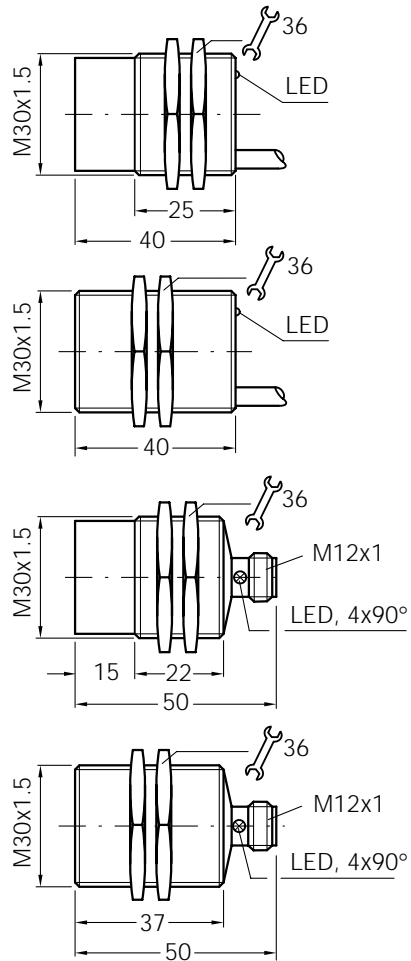

Connection diagram

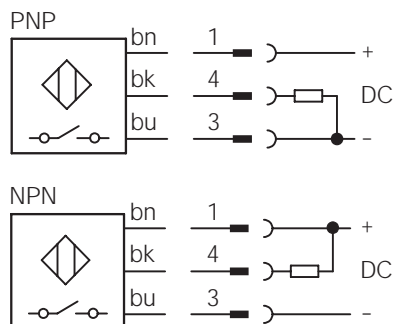



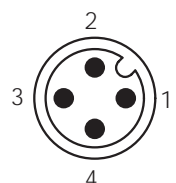













Wire colour	Colour	Contact	Assignment
bn	brown	1	+ V DC
bk	black	4	NO
bu	blue	3	- V DC



Electrical and mechanical data

Operating voltage U_b	10 ... 30 V DC	Wire-break protection	yes
Ripple U_{pp}	$\leq 10\%$ of U_b	Short-circuit protection (pulsed)	yes
Voltage drop U_d (at I_a max.)	≤ 1.5 V	Reverse polarity protection	yes
Power consumption (without load)	≤ 10 mA	Power-up pulse suppression	yes
Continuous current I_a	≤ 300 mA	Enclosure rating to EN 60529	IP 67
Time delay before availability t_v	≤ 15 ms	Shock and vibration stress	30 g, 11 ms 10 to 55 Hz, 1 mm
Hysteresis H	1% - 10% of s_r	Ambient temperature T_a	- 25 ... + 75 °C
Repeatability R (U_b and T_a constant)	$\leq 3\%$ of s_r	Housing material	Brass, nickel-plated, plastic
Temperature drift	$\pm 10\%$ of s_r	Tightening torque	50 Nm
EMC	to EN 60 947-5-2	Connection cable	PUR-PVC, 3 x 0.5 mm ²

Selection table

Sensing range s_n mm	Installation in metal	Switching output	Output function	Switching frequency f in Hz	Connection	Type	Order number
10		PNP		500	Cable 2 m	IM30-10BPS-ZUK	1017434
10		NPN		500	Cable 2 m	IM30-10BNS-ZUK	1017446
10		PNP		500	Connector M12 x 1 mm	IM30-10BPS-ZCK	1017436
10		NPN		500	Connector M12 x 1 mm	IM30-10BNS-ZCK	1017448
15		PNP		500	Cable 2 m	IM30-15NPS-ZUK	1017435
15		NPN		500	Cable 2 m	IM30-15NNS-ZUK	1017447
15		PNP		500	Connector M12 x 1 mm	IM30-15NPS-ZCK	1017437
15		NPN		500	Connector M12 x 1 mm	IM30-15NNS-ZCK	1017449

Inductive proximity sensors

IM 30 series, sensing range 15 / 20 mm

DC 3-wire, metal housing

Dimensions in mm



Advanced series

Features



- ▶ Enhanced sensing range
- ▶ Can be installed flush or non-flush in metal
- ▶ PNP or NPN output
- ▶ Normally open/ normally closed function
- ▶ High switching frequency
- ▶ Short-circuit protection (pulsed)
- ▶ Robust brass housing, nickel-plated with fine thread M30 x 1.5 mm
- ▶ Cable or connector
- ▶ Enclosure rating IP 67
- ▶ LED status indicator

Accessories

Round connectors
Mounting bracket

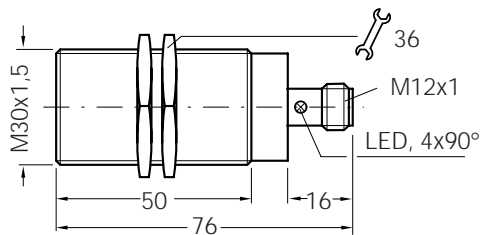
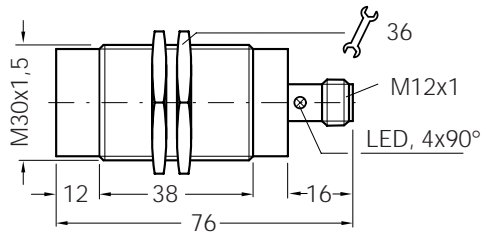
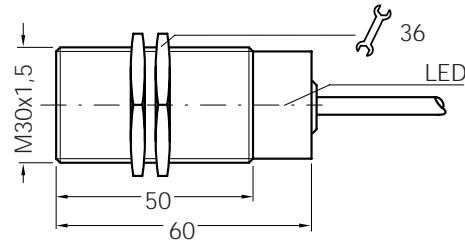
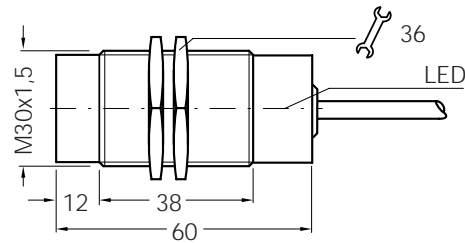

Connection diagram

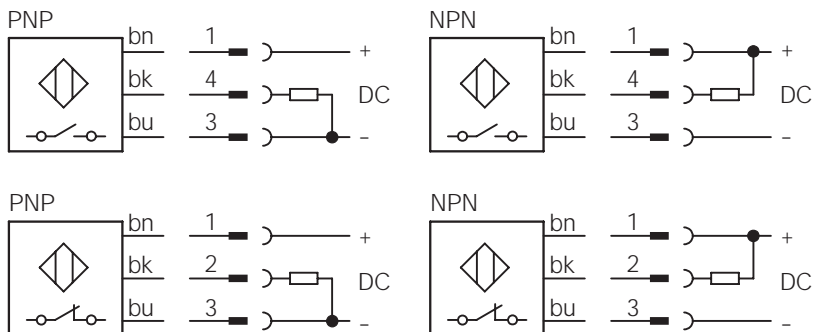

Wire colour	Contact	Assignment
bn	brown	1 + V DC
bk	black	2/4 NC/NO
bu	blue	3 - V DC

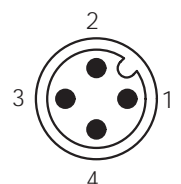

Electrical and mechanical data

Operating voltage U_b	10 ... 30 V DC	Short-circuit protection (pulsed)	yes
Ripple U_{pp}	$\leq 10\%$ of U_b	Reverse polarity protection	yes
Voltage drop U_d (at I_a max.)	≤ 1 V	Power-up pulse suppression	yes
Power consumption (without load)	≤ 10 mA	Enclosure rating to EN 60529	IP 67
Continuous current I_a	≤ 400 mA	Shock and vibration stress	30 g, 11 ms 10 to 55 Hz, 1 mm
Time delay before availability t_v	≤ 100 ms	Ambient temperature T_a	- 25 ... + 70 °C
Hysteresis H	2% - 15% of s_r	Housing material	Brass, nickel-plated, plastic
Repeatability R (U_b and T_a constant)	$\leq 5\%$ of s_r	Tightening torque	60 Nm
Temperature drift	$\pm 10\%$ of s_r	Connection cable	PVC, 3 x 0.5 mm ²
EMC	to EN 60 947-5-2		

Selection table

Sensing range s_n mm	Installation in metal	Switching output	Output function	Switching frequency f in Hz	Connection type	Type	Order number
15		PNP		150	Cable 2 m	IM30-15BPS-ZW1	7900141
15		NPN		150	Cable 2 m	IM30-15BNS-ZW1	7900142
15		PNP		150	Cable 2 m	IM30-15BPO-ZW1	7900143
15		PNP		150	Connector M12 x 1 mm	IM30-15BPS-ZC1	7900145
15		NPN		150	Connector M12 x 1 mm	IM30-15BNS-ZC1	7900146
15		PNP		150	Connector M12 x 1 mm	IM30-15BPO-ZC1	7900147
20		PNP		150	Cable 2 m	IM30-20NPS-ZW1	7900153
20		PNP		150	Cable 2 m	IM30-20NPO-ZW1	7900155
20		PNP		150	Connector M12 x 1 mm	IM30-20NPS-ZC1	7900157
20		NPN		150	Connector M12 x 1 mm	IM30-20NNS-ZC1	7900158

* see installation notes



Miniature series

Inductive proximity sensors

IH 03 series, sensing range 0.6 mm

DC 3-wire, miniature metal housing

Dimensions in mm

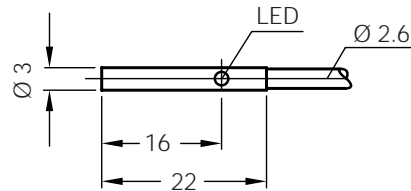

Features



- ▶ Can be installed flush
- ▶ PNP or NPN output
- ▶ Normally open function
- ▶ High switching frequency
- ▶ Short-circuit protection (pulsed)
- ▶ Solid stainless steel housing
- ▶ Cable
- ▶ Enclosure rating IP 67
- ▶ LED status indicator

Connection diagram

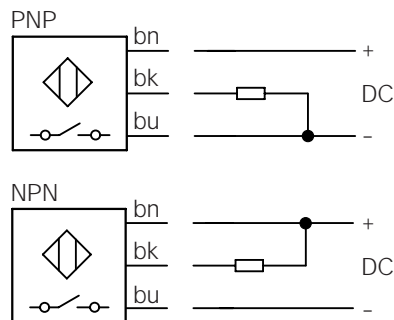





Wire colour	Assignment
bn brown	+ V DC
bk black	NO
bu blue	- V DC

Electrical and mechanical data

Operating voltage U_b	10 ... 30 V DC	Short-circuit protection (pulsed)	yes
Ripple U_{pp}	$\leq 20\%$ of U_b	Reverse polarity protection	yes
Voltage drop U_d (at I_a max.)	≤ 0.6 V max.	Power-up pulse suppression	yes
Power consumption (without load)	10 mA	Enclosure rating to EN 60529	IP 67
Continuous current I_a	≤ 100 mA	Shock and vibration stress	30 g, 11 ms 10 to 55 Hz, 1 mm
Time delay before availability t_v	≤ 10 ms	Ambient temperature T_a	- 25 ... + 70 °C
Hysteresis H	10% of s_r	Housing material	Stainless steel, plastic
Repeatability R (U_b and T_a constant)	$\leq 2\%$	Connection cable	PUR, 3 x 0.055 mm ²
Temperature drift	$\pm 10\%$ of s_r		
EMC	to EN 60 947-5-2		

Selection table

Sensing range s_n mm	Installation in metal	Switching output	Output function	Switching frequency f in Hz	Connection	Type	Order number
0.6		PNP		2000	Cable 2 m	IH03-0B6PS-VU1	6020141
0.6		NPN		2000	Cable 2 m	IH03-0B6NS-VU1	6020142

Normally closed function available on request



Inductive proximity sensors

IH 04 series, sensing range 0.8 mm

DC 3-wire, miniature metal housing

Dimensions in mm

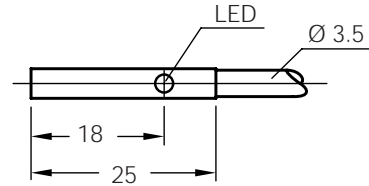

Miniature series

Features



- ▶ Can be installed flush
- ▶ PNP or NPN output
- ▶ Normally open function
- ▶ High switching frequency
- ▶ Short-circuit protection (pulsed)
- ▶ Solid stainless steel housing
- ▶ Cable or connector
- ▶ Enclosure rating IP 67
- ▶ LED status indicator

Accessories

Round connectors

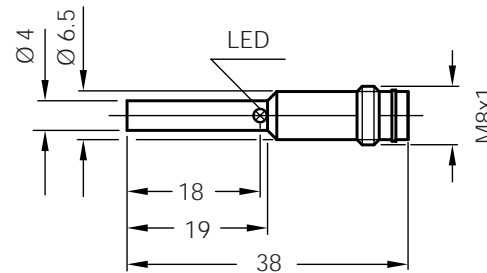

Connection diagram

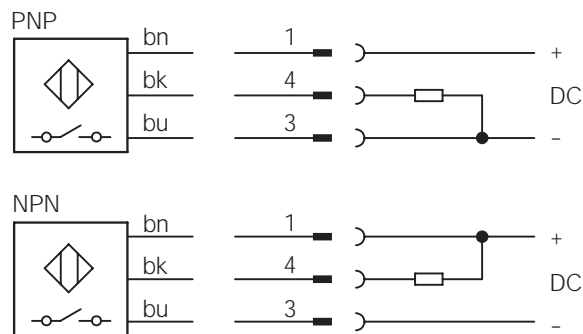



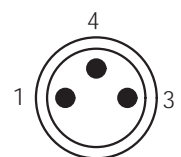





Wire colour	Contact	Assignment
bn brown	1	+ V DC
bk black	4	NO
bu blue	3	- V DC



Electrical and mechanical data

Operating voltage U_b	10 ... 30 V DC	Short-circuit protection (pulsed)	yes
Ripple U_{pp}	$\leq 20\%$ of U_b	Reverse polarity protection	yes
Voltage drop U_d (at I_a max.)	≤ 2.0 V max.	Power-up pulse suppression	yes
Power consumption (without load)	10 mA	Enclosure rating to DIN 40050	IP 67
Continuous current I_a	≤ 200 mA	Shock and vibration stress	30 g, 11 ms 10 to 55 Hz, 1 mm
Time delay before availability t_v	≤ 10 ms	Ambient temperature T_a	- 25 ... + 70 °C
Hysteresis H	10% of s_r	Housing material	Stainless steel, plastic
Repeatability R (U_b and T_a constant)	$\leq 1.5\%$	Connection cable	PVC, 3 x 0.14 mm ²
Temperature drift EMC	$\pm 10\%$ of s_r to EN 60 947-5-2		

Selection table

Sensing range s_n mm	Installation in metal	Switching output	Output function	Switching frequency f in Hz	Connection	Type	Order number
0.8		PNP		5000	Cable 2 m	IH04-0B8PS-VW1	6020113
0.8		NPN		5000	Cable 2 m	IH04-0B8NS-VW1	6020149
0.8		PNP		5000	Connector M8 x 1 mm	IH04-0B8PS-VT1	6020114
0.8		NPN		5000	Connector M8 x 1 mm	IH04-0B8NS-VT1	6020152

Normally closed function available on request

Inductive proximity sensors

IH 06 series, sensing range 1,5 mm

DC 3-wire, metal housing

Dimensions in mm



Miniature series

Features



- ▶ Can be installed flush
- ▶ PNP or NPN output
- ▶ Normally open function
- ▶ High switching frequency
- ▶ Short-circuit protection (pulsed)
- ▶ Solid stainless steel housing
- ▶ Cable or connector
- ▶ Enclosure rating IP 67
- ▶ LED status indicator

Accessories

Round connectors

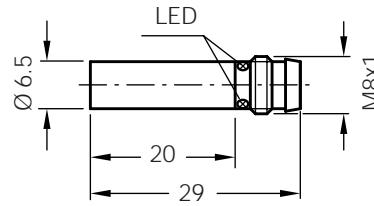
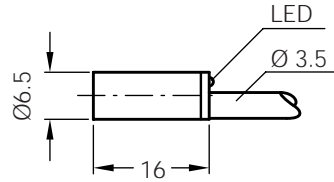

Connection diagram

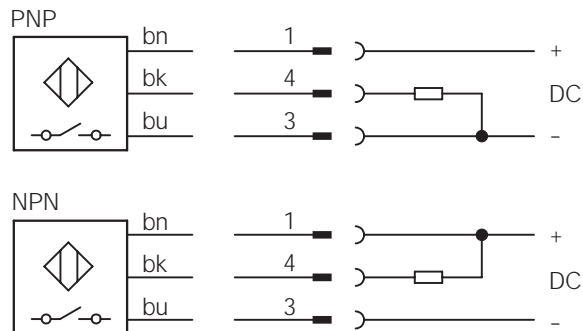



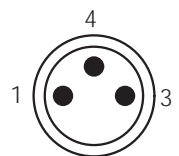





Wire colour	Colour	Contact	Assignment
bn	brown	1	+ V DC
bk	black	4	NO/NC
bu	blue	3	- V DC



Electrical and mechanical data

Operating voltage U_b	10 ... 30 V DC	Short-circuit protection (pulsed)	yes
Ripple U_{pp}	$\leq 20\%$ of U_b	Reverse polarity protection	yes
Voltage drop U_d (at I_a max.)	≤ 2.0 V max.	Power-up pulse suppression	yes
Power consumption (without load)	10 mA	Enclosure rating to EN 60529	IP 67
Continuous current I_a	≤ 200 mA	Shock and vibration stress	30 g, 11 ms 10 to 55 Hz, 1 mm
Time delay before availability t_v	≤ 10 ms	Ambient temperature T_a	- 25 ... + 70 °C
Hysteresis H	10% of s_r	Housing material	Stainless steel, plastic
Repeatability R (U_b and T_a constant)	$\leq 5\%$	Connection cable	PVC, 3 x 0.14 mm ²
Temperature drift	$\pm 10\%$ of s_r		
EMC	to EN 60 947-5-2		

Selection table

Sensing range s_n mm	Installation in metal	Switching output	Output function	Switching frequency f in Hz	Connection	Type	Order number
1.5		PNP		5000	Cable 2 m	IH06-1B5PS-VWK	6020165
1.5		NPN		5000	Cable 2 m	IH06-1B5NS-VWK	6020166
1.5		PNP		5000	Connector M8 x 1 mm	IH06-1B5PS-VTK	6020169
1.5		NPN		5000	Connector M8 x 1 mm	IH06-1B5NS-VTK	6020170

Accessories

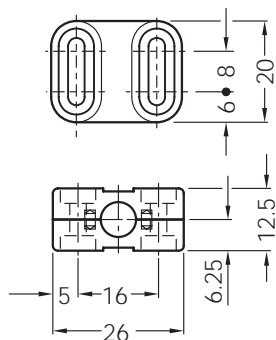

Mounting clamp for H06 type
Plastic with 2 screws

Order No. 7901771



Inductive proximity sensors

IH 06 series, sensing range 2 / 4 mm

DC 3-wire, metal housing

Dimensions in mm

Advanced series

Features



- ▶ Enhanced sensing range
- ▶ Can be installed flush or non-flush in metal
- ▶ PNP or NPN output
- ▶ Normally closed or normally open function
- ▶ High switching frequency
- ▶ Short-circuit protection (pulsed)
- ▶ Solid stainless steel housing
- ▶ Cable or connector
- ▶ Enclosure rating IP 67
- ▶ LED status indicator

Accessories

Round connectors

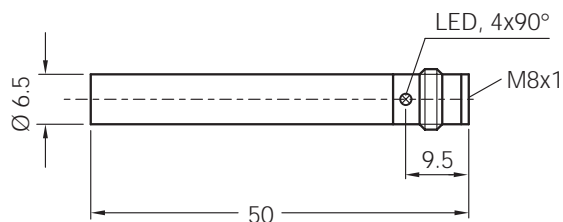
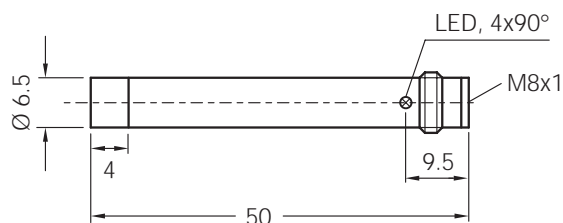
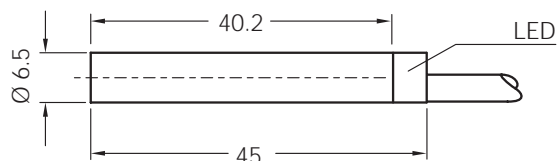
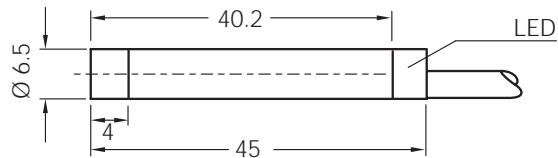

Connection diagram

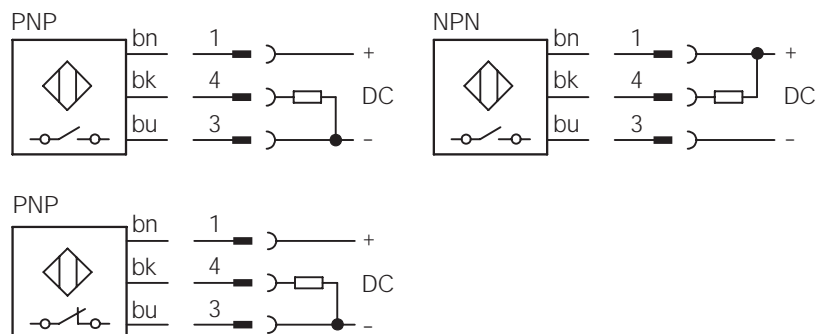

Wire colour	Contact	Assignment
bn	brown	1 + V DC
bk	black	4 NO/NC
bu	blue	3 - V DC

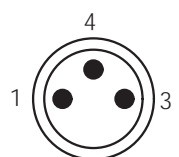

Electrical and mechanical data

Operating voltage U_b	10 ... 30 V DC	Short-circuit protection (pulsed)	yes
Ripple U_{pp}	$\leq 10\%$ of U_b	Reverse polarity protection	yes
Voltage drop U_d (at I_a max.)	≤ 1.2 V	Power-up pulse suppression	yes
Power consumption (without load)	≤ 20 mA	Enclosure rating to EN 60529	IP 67
Continuous current I_a	≤ 200 mA	Shock and vibration stress	30 g, 11 ms 10 to 55 Hz, 1 mm
Time delay before availability t_v	≤ 100 ms	Ambient temperature T_a	- 25 ... + 70 °C
Hysteresis H	2% - 15% of s_r	Housing material	Stainless steel, plastic
Repeatability R (U_b and T_a constant)	$\leq 5\%$ of s_r	Connection cable	PVC, 3 x 0.14 mm ²
Temperature drift	$\pm 10\%$ of s_r		
EMC	to EN 60 947-5-2		

Selection table

Sensing range s_n mm	Installation in metal	Switching output	Output function	Switching frequency f in Hz	Connection	Type	Order number
2		PNP		3000	Cable 2 m	IH06-02BPS-VW1	7900177
2		NPN		3000	Cable 2 m	IH06-02BNS-VW1	7900178
2		PNP		3000	Connector M8 x 1 mm	IH06-02BPS-VT1	7900179
2		NPN		3000	Connector M8 x 1 mm	IH06-02BNS-VT1	7900180
2		PNP		3000	Connector M8 x 1 mm	IH06-02BPO-VT1	1016857
4		PNP		3000	Cable 2 m	IH06-04NPS-VW1	7900181
4		NPN		3000	Cable 2 m	IH06-04NNS-VW1	7900182
4		PNP		3000	Connector M8 x 1 mm	IH06-04NPS-VT1	7900183

* see installation notes

Accessories

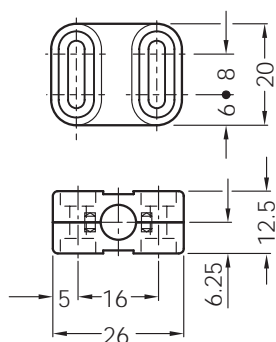

Mounting clamp for H06 type
Plastic with 2 screws

Order No. 7901771



Inductive proximity sensors

IQ 05 series, sensing range 0.8 mm

DC 3-wire, miniature metal housing

Dimensions in mm

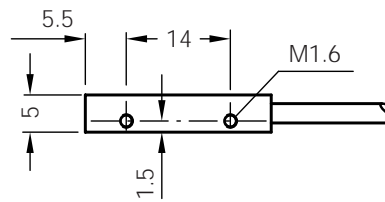
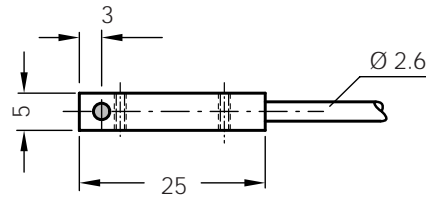

Features



- ▶ Can be installed flush
- ▶ PNP or NPN output
- ▶ Normally open function
- ▶ High switching frequency
- ▶ Short-circuit protection (pulsed)
- ▶ Robust brass housing, nickel-plated
- ▶ Cable
- ▶ Enclosure rating IP 67
- ▶ LED status indicator

Connection diagram

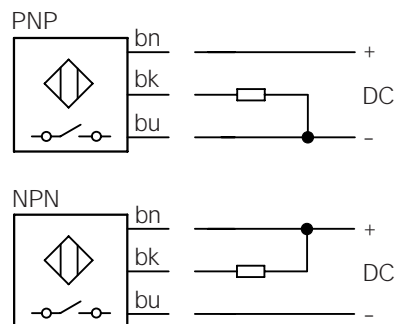





Wire colour	Assignment
bn brown	+ V DC
bk black	NO
bu blue	- V DC

Electrical and mechanical data

Operating voltage U_b	10 ... 30 V DC	Short-circuit protection (pulsed)	yes
Ripple U_{pp}	$\leq 20\%$ of U_b	Reverse polarity protection	yes
Voltage drop U_d (at $I_a = 200$ mA)	≤ 2.0 V max.	Power-up pulse suppression	yes
Power consumption (without load)	≤ 10 mA	Enclosure rating to EN 60529	IP 67
Continuous current I_a	≤ 200 mA	Shock and vibration stress	30 g, 11 ms 10 to 55 Hz, 1 mm
Time delay before availability t_v	≤ 10 ms	Ambient temperature T_a	- 25 ... + 70 °C
Hysteresis H	10% of s_r	Housing material	Brass, nickel-plated, plastic
Repeatability R (U_b and T_a constant)	$\leq 1.5\%$ of s_r	Connection cable	PUR, 3 x 0.055 mm ²
Temperature drift EMC	$\pm 10\%$ of s_r to EN 60 947-5-2		

Selection table

Sensing range s_n mm	Installation in metal	Switching output	Output function	Switching frequency f in Hz	Connection	Type	Order number
0.8		PNP		5000	Cable 2 m	IQ05-0B8PS-ZU1	6020161
0.8		NPN		5000	Cable 2 m	IQ05-0B8NS-ZU1	6020162

Normally closed function available on request



Inductive proximity sensors

IQ 08 series, sensing range 2 / 4 mm

DC 3-wire, plastic housing

Dimensions in mm

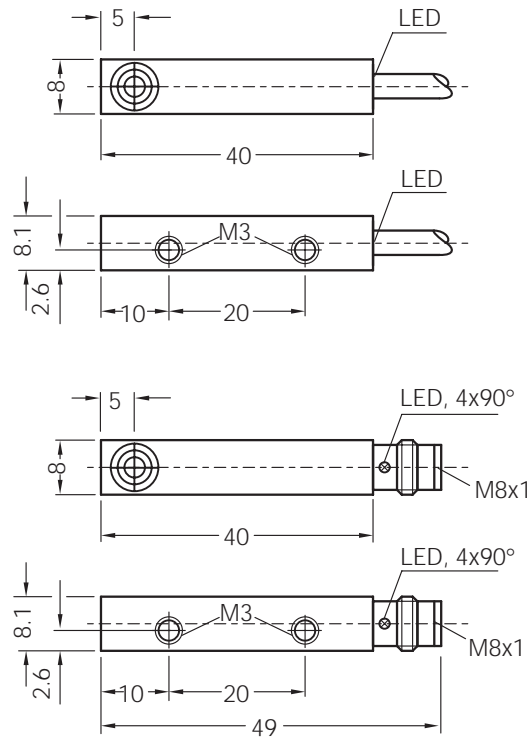

Features



- ▶ Can be installed flush or non-flush in metal
- ▶ PNP or NPN output
- ▶ High switching frequency
- ▶ Short-circuit protection (pulsed)
- ▶ Small plastic housing
- ▶ Cable or connector
- ▶ Enclosure rating IP 67
- ▶ LED status indicator
- ▶ For the series IQ08-04N the added plastic screws shall be used
- ▶ Installation notes see page 17

Accessories

Round connectors

Connection diagram

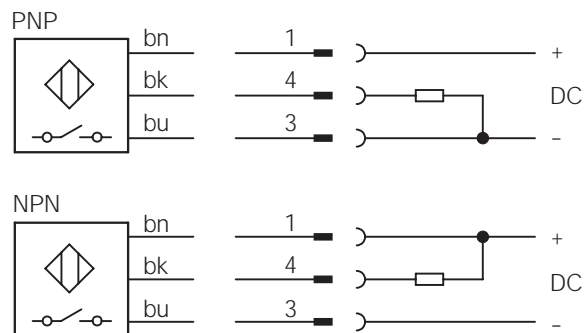



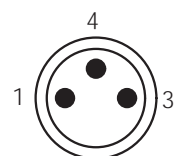









Wire colour	Colour	Contact	Assignment
bn	brown	1	+ V DC
bk	black	4	NO
bu	blue	3	- V DC



Electrical and mechanical data

Operating voltage U_b	10 ... 30 V DC	Wire-break protection	yes
Ripple U_{pp}	$\leq 10\%$ of U_b	Short-circuit protection (pulsed)	yes
Voltage drop U_d (at I_a max.)	≤ 1.5 V	Reverse polarity protection	yes
Power consumption (without load)	≤ 10 mA	Power-up pulse suppression	yes
Continuous current I_a	≤ 300 mA	Enclosure rating to EN 60529	IP 67
Time delay before availability t_v	≤ 2 ms	Shock and vibration stress	30 g, 11 ms 10 to 55 Hz, 1 mm
Hysteresis H	1% - 10% of s_r	Ambient temperature T_a	- 25 ... + 75 °C
Repeatability R (U_b and T_a constant)	$\leq 1\%$ of s_r	Housing material	Plastic
Temperature drift	$\pm 10\%$ of s_r	Connection cable	PVC, 3 x 0.25 mm ²
EMC	to EN 60 947-5-2		

Selection table

Sensing range s_n mm	Installation in metal	Switching output	Output function	Switching frequency f in Hz	Connection	Type	Order number
2		PNP		5000	Cable 2 m	IQ08-02BPS-KW1	7900195
2		NPN		5000	Cable 2 m	IQ08-02BNS-KW1	7900196
2		PNP		5000	Connector M8 x 1 mm	IQ08-02BPS-KT1	7900197
2		NPN		5000	Connector M8 x 1 mm	IQ08-02BNS-KT1	7900198
4		PNP		5000	Cable 2 m	IQ08-04NPS-KW1	7900199
4		PNP		5000	Connector M8 x 1 mm	IQ08-04NPS-KT1	7900201

Inductive proximity sensors

IQ 10 series, sensing range 3 / 6 mm

DC 3-wire, plastic housing

Dimensions in mm



Features



- ▶ Can be installed flush or non-flush in metal
- ▶ PNP or NPN output
- ▶ Normally closed or normally open function
- ▶ High switching frequency
- ▶ Short-circuit protection (pulsed)
- ▶ Plastic housing
- ▶ Cable or connector
- ▶ Enclosure rating IP 67
- ▶ LED status indicator
- ▶ Installation notes see page 17

Accessories

Round connectors

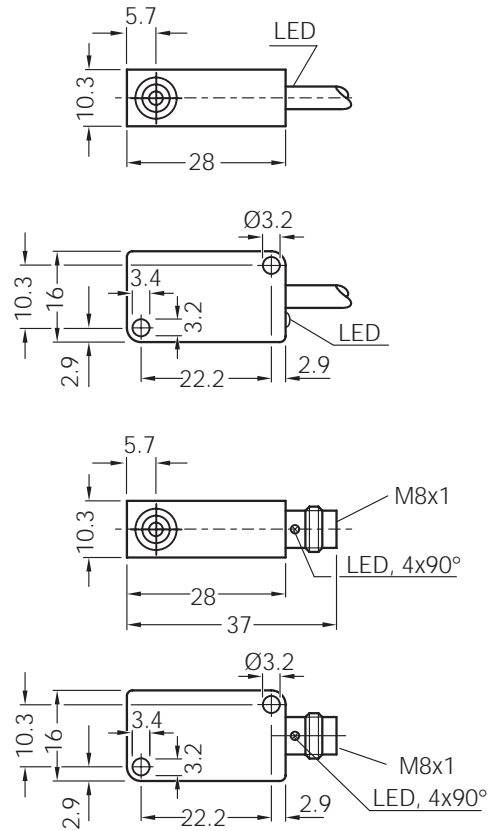

Connection diagram

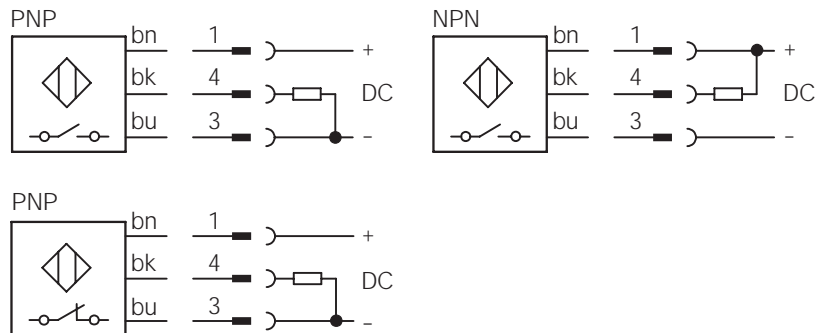



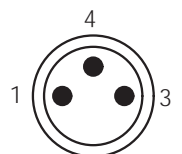















Wire colour	Contact	Assignment
bn brown	1	+ V DC
bk black	4	NO
bu blue	3	- V DC



Electrical and mechanical data

Operating voltage U_b	10 ... 30 V DC	Wire-break protection	yes
Ripple U_{pp}	$\leq 10\%$ of U_b	Short-circuit protection (pulsed)	yes
Voltage drop U_d (at I_a max.)	≤ 1.5 V	Reverse polarity protection	yes
Power consumption (without load)	≤ 5 mA	Power-up pulse suppression	yes
Continuous current I_a	≤ 300 mA	Enclosure rating to EN 60529	IP 67
Time delay before availability t_v	≤ 10 ms	Shock and vibration stress	30 g, 11 ms 10 to 55 Hz, 1 mm
Hysteresis H	1% - 15% of s_r	Ambient temperature T_a	- 25 ... + 75 °C
Repeatability R (U_b and T_a constant)	$\leq 1\%$ of s_r	Housing material	Plastic
Temperature drift EMC	$\pm 10\%$ of s_r to EN 60 947-5-2	Connection cable	PVC, 3 x 0.25 mm ²

Selection table

Sensing range s_n mm	Installation in metal	Switching output	Output function	Switching frequency f in Hz	Connection	Type	Order number
3		PNP		3000	Cable 2 m	IQ10-03BPS-KW1	7900203
3		NPN		3000	Cable 2 m	IQ10-03BNS-KW1	7900204
3		PNP		3000	Connector M8 x 1 mm	IQ10-03BPS-KT1	7900205
3		NPN		3000	Connector M8 x 1 mm	IQ10-03BNS-KT1	7900206
3		PNP		3000	Connector M8 x 1 mm	IQ10-03BPO-KT1	7901530
6		PNP		1000	Cable 2 m	IQ10-06NPS-KW1	7900207
6		NPN		1000	Cable 2 m	IQ10-06NNS-KW1	7900208
6		PNP		1000	Connector M8 x 1 mm	IQ10-06NPS-KT1	7900209
6		NPN		1000	Connector M8 x 1 mm	IQ10-06NNS-KT1	7900210



Inductive proximity sensors

IQ 12 series, sensing range 3 / 6 mm

DC 3-wire, plastic housing

Dimensions in mm

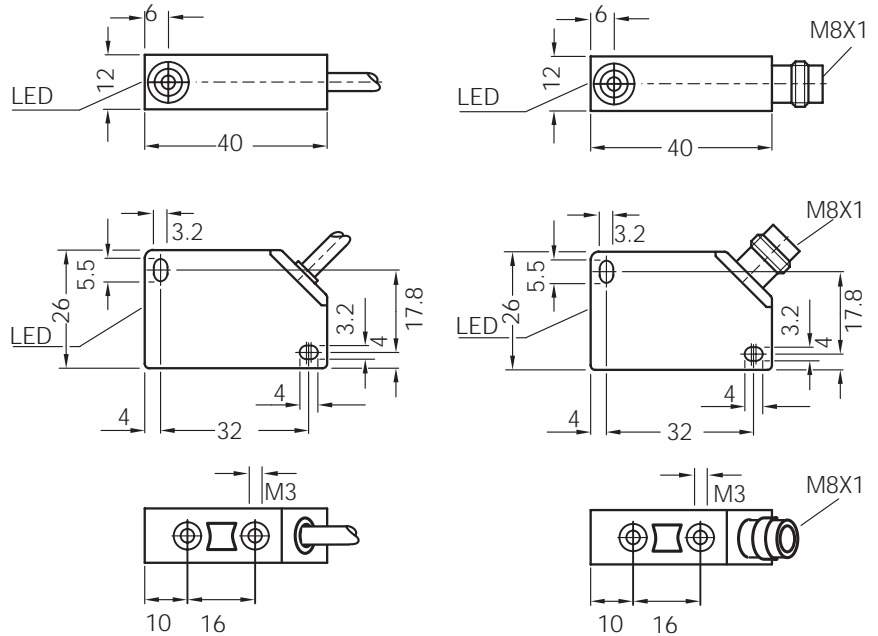

Features



- ▶ Can be installed flush or non-flush in metal
- ▶ PNP or NPN output
- ▶ High switching frequency
- ▶ Short-circuit protection (pulsed)
- ▶ Plastic housing
- ▶ Cable or connector
- ▶ Enclosure rating IP 67
- ▶ LED status indicator
- ▶ Installation notes see page 17

Accessories

Round connectors

Connection diagram

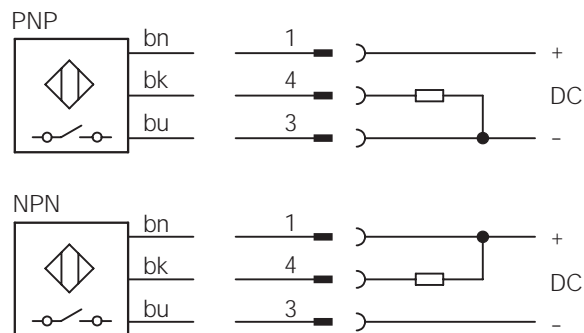



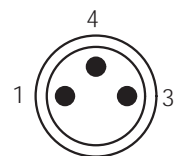









Wire colour	Wire colour	Contact	Assignment
bn	brown	1	+ V DC
bk	black	4	NO
bu	blue	3	- V DC



Electrical and mechanical data

Operating voltage U_b	6 ... 36 V DC	Wire-break protection	yes
Ripple U_{pp}	$\leq 10\%$ of U_b	Short-circuit protection (pulsed)	yes
Voltage drop U_d (at I_a max.)	≤ 1.5 V	Reverse polarity protection	yes
Power consumption (without load)	≤ 5 mA	Power-up pulse suppression	yes
Continuous current I_a	≤ 300 mA	Enclosure rating to EN 60529	IP 67
Time delay before availability t_v	≤ 10 ms	Shock and vibration stress	30 g, 11 ms 10 to 55 Hz, 1 mm
Hysteresis H	1% - 15% of s_r	Ambient temperature T_a	- 25 ... + 75 °C
Repeatability R (U_b and T_a constant)	$\leq 1\%$ of s_r	Housing material	Plastic
Temperature drift	$\pm 10\%$ of s_r	Connection cable	PVC, 3 x 0.25 mm ²
EMC	to EN 60 947-5-2		

Selection table

Sensing range s_n mm	Installation in metal	Switching output	Output function	Switching frequency f in Hz	Connection	Type	Order number
3		PNP		3000	Cable 2 m	IQ12-03BPS-KW1	1016275
3		NPN		3000	Cable 2 m	IQ12-03BNS-KW1	1016299
3		PNP		3000	Connector M8 x 1 mm	IQ12-03BPS-KT1	1016276
3		NPN		3000	Connector M8 x 1 mm	IQ12-03BNS-KT1	1016461
6		PNP		1000	Cable 2 m	IQ12-06NPS-KW1	1016463
6		PNP		1000	Connector M8 x 1 mm	IQ12-06NPS-KT1	1016467

Inductive proximity sensors

IQ 40 series, sensing range 15 / 20 mm

DC 3-wire, plastic housing

Dimensions in mm

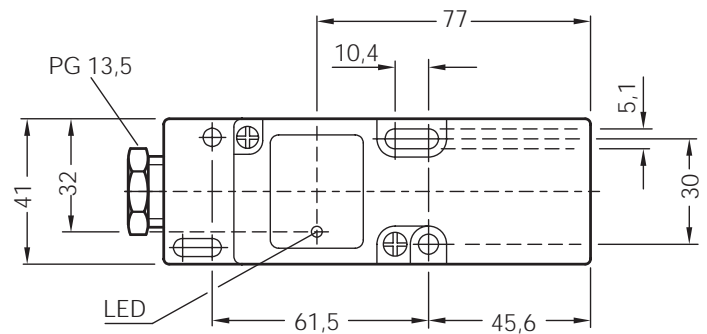
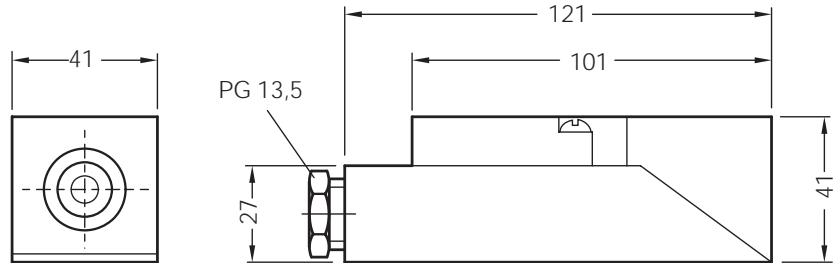

Features



- ▶ Can be installed flush or non-flush in metal
- ▶ Variable switching zone
- ▶ PNP output
- ▶ Programmable NO/NC function
- ▶ Short-circuit protection (pulsed)
- ▶ Plastic housing
- ▶ Terminal
- ▶ Enclosure rating IP 65
- ▶ LED status indicator
- ▶ Installation notes see page 17
- ▶  

Connection diagram

PNP

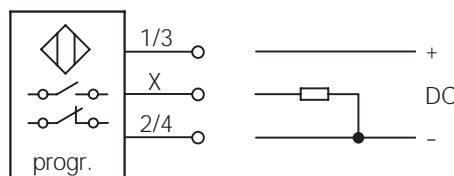



Programming with wirelinks
 Link closed: NO
 Link open: NC

Terminal	Assignment
1/3	+ V DC
X	NO/NC
2/4	- V DC

Electrical and mechanical data

Operating voltage U_b	10 ... 36 V DC	Short-circuit protection (pulsed)	yes
Voltage drop U_d (at I_a max. and U_b 24 V)	≤ 2.5 V	Reverse polarity protection	yes
Power consumption (without load)	≤ 15 mA	Power-up pulse suppression	yes
Continuous current I_a	≤ 250 mA	Enclosure rating to EN 60529	IP 65
Time delay before availability t_v	approx. 4 ms	Protection class	□
Hysteresis H	1% - 15% of s_r	Shock and vibration stress	30 g, 11 ms 10 to 55 Hz, 1 mm
Repeatability R (U_b and T_a constant)	$\leq 10\%$ of s_r	Ambient temperature T_a	- 25 ... + 80 °C
Temperature drift	$\pm 10\%$ of s_r	Housing material	Plastic
EMC	to EN 60 947-5-2		

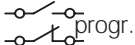
Selection table

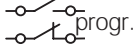
Sensing range s_n mm	Installation in metal	Switching output	Output function	Switching frequency f in Hz	Connection	Type	Order number
15		PNP		300	Terminal up to 2.5 mm ²	IQ40-15BPP-KK0	7900219
20		PNP		300	Terminal up to 2.5 mm ²	IQ40-20NPP-KK0	7900221



Short version

Inductive proximity sensors

IQ 40 series, sensing range 15 / 20 / 35 mm

DC 3/4-wire, plastic housing

Dimensions in mm

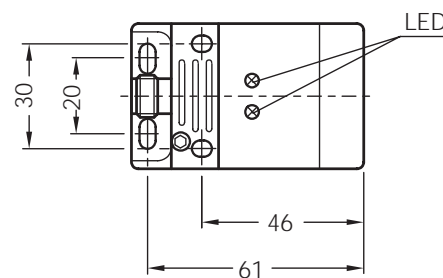
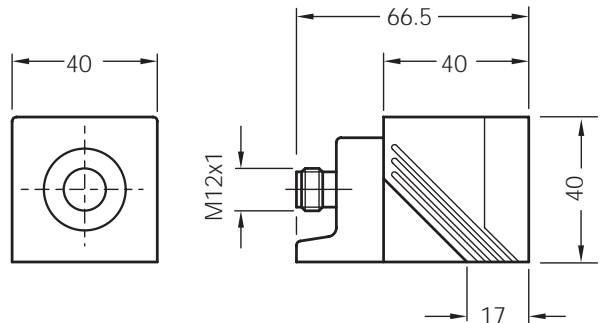

Features



- ▶ Can be installed flush or non-flush in metal
- ▶ Variable switching zone
- ▶ PNP output
- ▶ NO and complementary output function
- ▶ Short-circuit protection (pulsed)
- ▶ Plastic housing
- ▶ Connector
- ▶ Enclosure rating IP 67
- ▶ LED status indicator
- ▶ LED function indicator
- ▶ Installation notes see page 17
- ▶ (only normally open function)

Accessories

Round connectors

Connection diagram

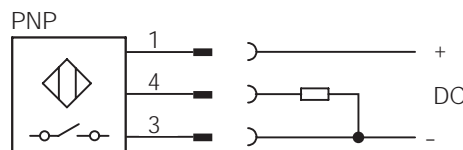

Contact	Assignment
1	+ V DC
4	NO
3	- V DC
2	free

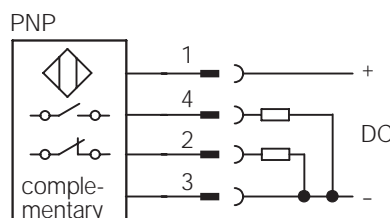



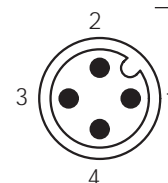





Contact	Assignment
1	+ V DC
2	NC
3	- V DC
4	NO



Electrical and mechanical data

Operating voltage U_b	10 ... 36 V DC	Short-circuit protection (pulsed)	yes
Voltage drop U_d (at I_a max. and U_b 24 V)	≤ 2.5 V	Reverse polarity protection	yes
Power consumption (without load)	≤ 15 mA	Power-up pulse suppression	yes
Continuous current I_a	≤ 250 mA	Enclosure rating to EN 60529	IP 67
Time delay before availability t_v	approx. 4 ms	Protection class	□
Hysteresis H	1% - 15% of s_r	Shock and vibration stress	30 g, 11 ms 10 to 55 Hz, 1 mm
Repeatability R (U_b and T_a constant)	$\leq 10\%$ of s_r	Ambient temperature T_a	- 25 ... + 70 °C
Temperature drift	$\pm 10\%$ of s_r	Housing material	Plastic
EMC	to EN 60 947-5-2		

Selection table

Sensing range s_n mm	Installation in metal	Switching output	Output function	Switching frequency f in Hz	Connection	Type	Order number
15		PNP		300	Connector M12 x 1 mm	IQ40-15BPS-KC0	7900223
20		PNP	 antivalent	200	Connector M12 x 1 mm	IQ40-20BPP-KCK	6012014
35		PNP		100	Connector M12 x 1 mm	IQ40-35NPS-KC0	7900224
35		PNP	 antivalent	100	Connector M12 x 1 mm	IQ40-35NPP-KCK	6012015

Inductive proximity sensors

IQ 80 series, sensing range 60 mm

DC 3-wire, plastic housing

Dimensions in mm

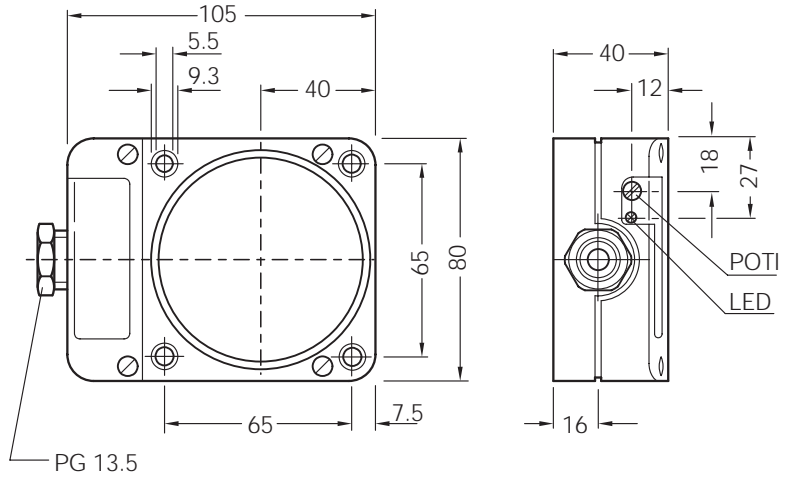
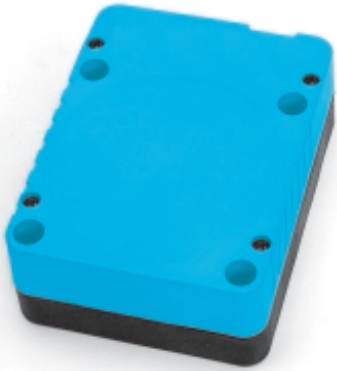

Features



- ▶ Can be installed non-flush in metal
- ▶ Adjustable switching distance between 20 to 60 mm
- ▶ PNP output
- ▶ Programmable NO/NC function
- ▶ Short-circuit protection (pulsed)
- ▶ Robust plastic housing
- ▶ Terminal connection
- ▶ Enclosure rating IP 65
- ▶ LED status indicator
- ▶

Connection diagram

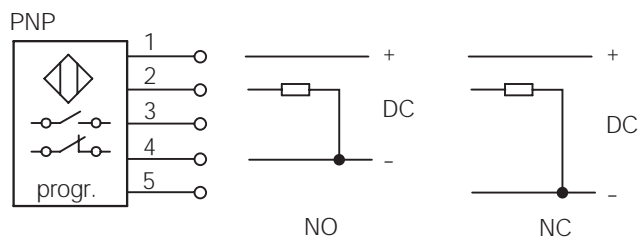

Terminal	Assignment
1	+ V DC
2	Output
3	free
4	- V DC / NO
5	- V DC / NC

Electrical and mechanical data

Operating voltage U_b	10 ... 36 V DC	Short-circuit protection (pulsed)	yes
Voltage drop U_d	≤ 2.5 V at I_a max. and U_b 24 V	Reverse polarity protection	yes
Power consumption (without load)	≤ 15 mA	Power-up pulse suppression	yes
Continuous current I_a	≤ 250 mA	Enclosure rating to EN 60529	IP 65
Time delay before availability t_v	approx. 250 ms	Protection class	
Hysteresis H	1% - 15% of s_r	Shock and vibration stress	30 g, 11 ms 10 to 55 Hz, 1 mm
Repeatability R (U_b and T_a constant)	$\leq 10\%$ of s_r	Ambient temperature T_a	- 25 ... + 80 °C
Temperature drift	$\pm 10\%$ of s_r	Housing material	Plastic
EMC	to EN 60 947-5-2		

Selection table

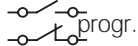
Sensing range s_n mm	Installation in metal	Switching output	Output function	Switching frequency f in Hz	Connection	Type	Order number
60		PNP		4	Terminal up to 2.5 mm ²	IQ80-60NPP-KK0	7900227



Inductive proximity sensors

IM 12 series, sensing range 2 / 4 mm

DC 2-wire, metal housing

Dimensions in mm

Features



- ▶ Can be installed flush or non-flush in metal
- ▶ Normally open function
- ▶ Short-circuit protection (pulsed)
- ▶ Robust brass housing, nickel-plated with fine thread M12 x 1 mm
- ▶ Cable or connector
- ▶ Enclosure rating IP 67
- ▶ LED-status indicator

Accessories

Round connector
Mounting bracket

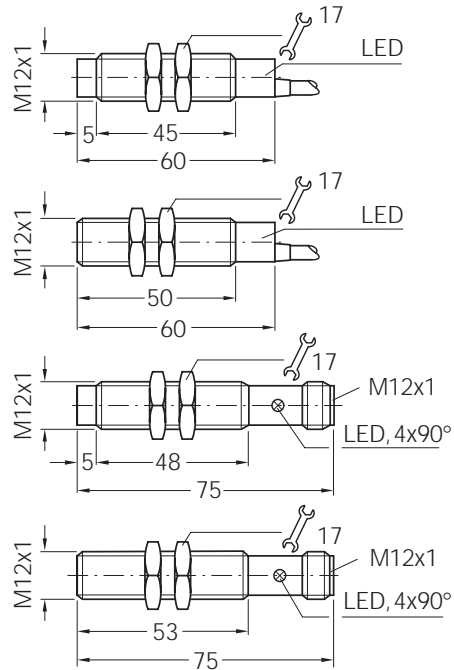

Connection diagram

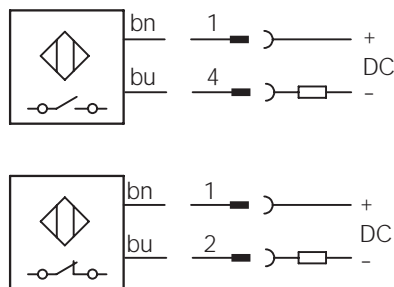



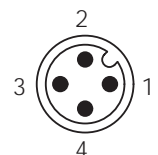





Wire colour	Contact	Assignment
bn brown	1	+ V DC
bu blue	2/4	- V DC



Electrical and mechanical data

Operating voltage U_b	10 ... 30 V DC	Short-circuit protection (pulsed)	yes
Ripple U_{pp}	$\leq 10\%$	Reverse polarity protection	yes
Voltage drop U_d (at I_a max)	≤ 2.8 V	Enclosure rating to EN 60529	IP 67
Load current	≥ 3 mA	Shock and vibration stress	30 g, 11 ms 10 bis 55 Hz, 1 mm
Continuous current I_a	≤ 100 mA	Ambient temperature T_a	- 25 ... + 70 °C
Off state current	≤ 0.8 mA	Housing material	Brass, nickel-plated, plastic
Time delay before availability t_v	≤ 50 ms	Tightening torque	10 Nm
Hysteresis H	2% - 10% of s_r	Connection cable	PVC, 2 x 0.22 mm ²
Repeatability R (U_b and T_a constant)	$\leq 5\%$ of s_r		
Temperature drift	$\pm 10\%$ of s_r		
EMC	to EN 60 947-5-2		

Selection table

Sensing range s_n mm	Installation in metall	Output function	Switching frequency f in Hz	Connection	Type	Order number
2			1500	Cable 2 m	IM12-02BDS-ZW1	6020310
2			1500	Connector M12 x 1 mm	IM12-02BDS-ZC1	6020312
4			1500	Cable 2 m	IM12-04NDS-ZW1	6020314
4			1500	Connector M12 x 1 mm	IM12-04NDS-ZC1	6020316

Normally closed function available on request



Inductive proximity sensors

IM 18 series, sensing range 5 / 8 mm

DC 2-wire, metal housing

Dimensions in mm

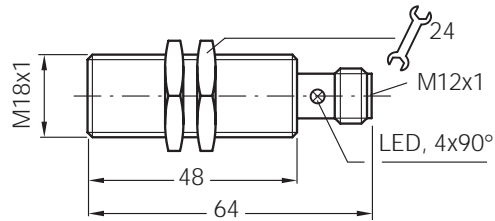
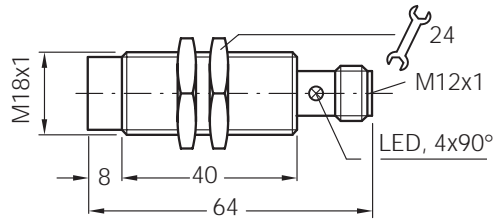
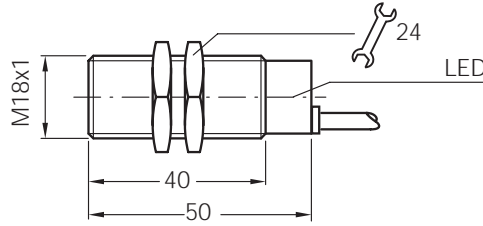
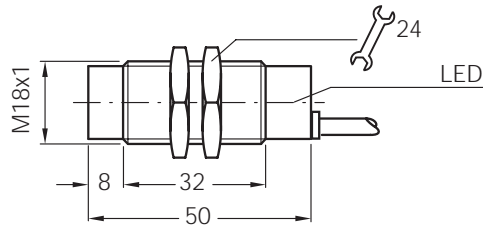

Features



- ▶ Can be installed flush or non-flush in metal
- ▶ Normally open function
- ▶ Short-circuit protection (pulsed)
- ▶ Robust brass housing, nickel-plated with fine thread M18 x 1 mm
- ▶ Cable or connector
- ▶ Enclosure rating IP 67
- ▶ LED-status indicator

Accessories

- Round connector
- Mounting bracket

Connection diagram

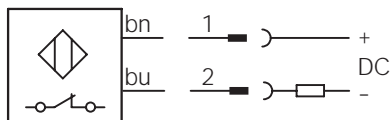
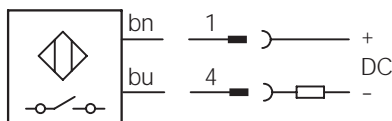



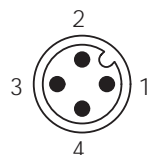





Wire colour	Contact	Assignment
bn brown	1	+ V DC
bu blue	2/4	- V DC



Electrical and mechanical data

Operating voltage U_b	10 ... 30 V DC	Short-circuit protection (pulsed)	yes
Ripple U_{pp}	$\leq 10\%$	Reverse polarity protection	yes
Voltage drop U_d (at I_a max)	≤ 2.8 V	Enclosure rating to EN 60529	IP 67
Load current	≥ 3 mA	Shock and vibration stress	30 g, 11 ms 10 bis 55 Hz, 1 mm
Continuous current I_a	≤ 100 mA	Ambient temperature T_a	- 25 ... + 70 °C
Off state current	≤ 0.8 mA	Housing material	Brass nickel-plated, plastic
Time delay before availability t_v	≤ 50 ms	Tightening torque	30 Nm
Hysteresis H	2% - 10% of s_r	Connection cable	PVC, 2 x 0.34 mm ²
Repeatability R (U_b and T_a constant)	$\leq 2\%$ of s_r		
Temperature drift	$\pm 10\%$ of s_r		
EMC	to EN 60 947-5-2		

Selection table

Sensing range s_n mm	Installation in metall	Output function	Switching frequency f in Hz	Connection	Type	Order number
5			300	Cable 2 m	IM18-05BDS-ZW1	6020318
5			300	Connector M12 x 1 mm	IM18-05BDS-ZC1	6020320
8			300	Cable 2 m	IM18-08NDS-ZW1	6020322
8			300	Connector M12 x 1 mm	IM18-08NDS-ZC1	6020324

Normally closed function available on request

Inductive proximity sensors

IM 30 series, sensing range 10 / 15 mm

DC 2-wire, metal housing



Dimensions in mm

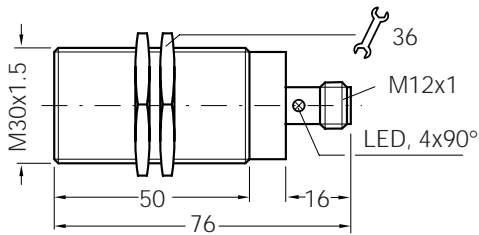
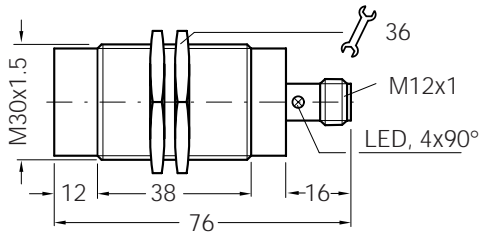
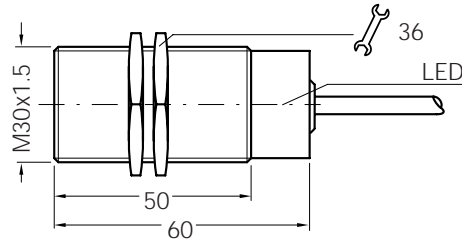
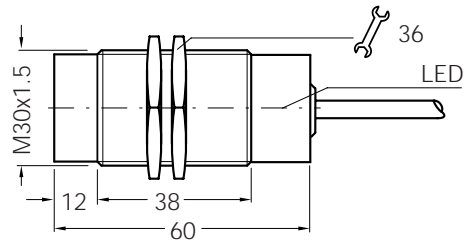

Features



- ▶ Can be installed flush or non-flush in metal
- ▶ Normally open function
- ▶ Short-circuit protection (pulsed)
- ▶ Robust brass housing, nickel-plated with fine thread M30 x 1 mm
- ▶ Cable or connector
- ▶ Enclosure rating IP 67
- ▶ LED-status indicator

Accessories

- Round connector
- Mounting bracket

Connection diagram

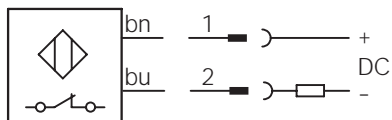
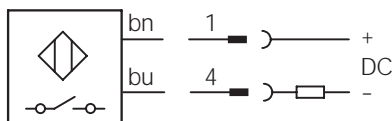



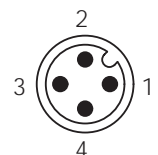





Wire colour	Contact	Assignment
bn brown	1	+ V DC
bu blue	2/4	- V DC



Electrical and mechanical data

Operating voltage U_b	10 ... 30 V DC	Short-circuit protection (pulsed)	yes
Ripple U_{pp}	$\leq 10\%$	Reverse polarity protection	yes
Voltage drop U_d (at I_a max)	≤ 2.8 V	Enclosure rating to EN 60529	IP 67
Load current	≥ 3 mA	Shock and vibration stress	30 g, 11 ms 10 bis 55 Hz, 1 mm
Continuous current I_a	≤ 100 mA	Ambient temperature T_a	- 25 ... + 70 °C
Off state current	≤ 0.8 mA	Housing material	Brass, nickel-plated, plastic
Time delay before availability t_v	≤ 50 ms	Tightening torque	60 Nm
Hysteresis H	2% - 10% of s_r	Connection cable	PVC, 2 x 0.34 mm ²
Repeatability R (U_b and T_a constant)	$\leq 2\%$ of s_r		
Temperature drift	$\pm 10\%$ of s_r		
EMC	to EN 60 947-5-2		

Selection table

Sensing range s_n mm	Installation in metall	Output function	Switching frequency f in Hz	Connection	Type	Order number
10			150	Cable 2 m	IM30-10BDS-ZW1	6020326
10			150	Connector M12 x 1 mm	IM30-10BDS-ZC1	6020328
15			150	Cable 2 m	IM30-15NDS-ZW1	6020330
15			150	Connector M12 x 1 mm	IM30-15NDS-ZC1	6020332

Normally closed function available on request



Inductive proximity sensors

IM 12 series, sensing range 2 / 4 mm

AC 2-wire, metal housing

Dimensions in mm

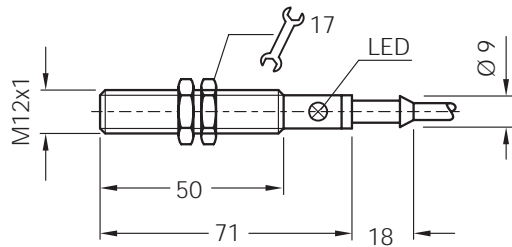
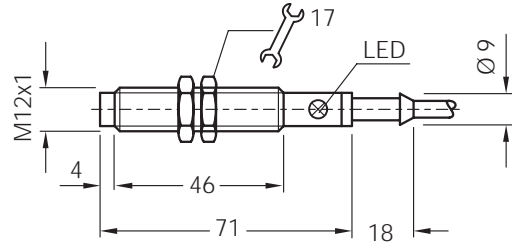

Features



- ▶ Can be installed flush or non-flush in metal
- ▶ Broad operating voltage range in AC
- ▶ Normally open/ normally closed function
- ▶ Robust brass housing, nickel-plated, with fine thread M12 x 1 mm
- ▶ Enclosure rating IP 67
- ▶ LED status indicator

Accessories

Mounting bracket

Connection diagram

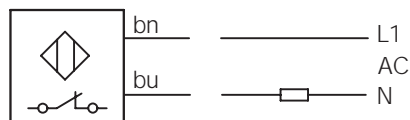
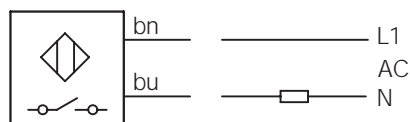

Wire colour	Assignment
bn brown	L1
bu blue	N

Electrical and mechanical data

Operating voltage U_b	20 ... 250 V AC	Wire-break protection	-
Voltage drop U_d (at I_a max.)	≤ 8.5 V AC	Short-circuit protection (pulsed)	-
Continuous current I_a	≤ 250 mA AC (... + 50 °C) ≤ 200 mA AC (... + 80 °C)	Reverse polarity protection	-
Peak current I_k	0.9 A (20 ms/0.5 Hz)	Power-up pulse suppression	yes
Min. load current	8 mA	Enclosure rating to EN 60529	IP 67
Residual current	≤ 3 mA (250 V AC) ≤ 1.5 mA (120 V AC)	Protection class	<input type="checkbox"/>
Time delay before availability t_v	approx. 10 ms	Shock and vibration stress	30 g, 11 ms 10 to 55 Hz, 1 mm
Hysteresis H	1% - 15% of s_r	Ambient temperature T_a	- 25 ... + 80 °C
Repeatability R (U_b and T_a constant)	$\leq 10\%$ of s_r	Housing material	Brass, nickel-plated, plastic
Temperature drift	$\pm 10\%$ of s_r	Tightening torque	7 Nm
EMC	to EN 60 947-5-2	Connection cable	PUR-PVC, 2 x 0.5 mm ²

Selection table

Sensing range s_n mm	Installation in metal	Output function	Switching frequency f in Hz	Connection	Type	Order number
2			25	Cable 2 m	IM12-02BAS-ZU0	7902118
2			25	Cable 2 m	IM12-02BAO-ZU0	7902119
4			25	Cable 2 m	IM12-04NAS-ZU0	7902120
4			25	Cable 2 m	IM12-04NAO-ZU0	7902121



Inductive proximity sensors

IM 18 series, sensing range 5 / 8 mm

AC / DC 2-wire, metal housing

Dimensions in mm

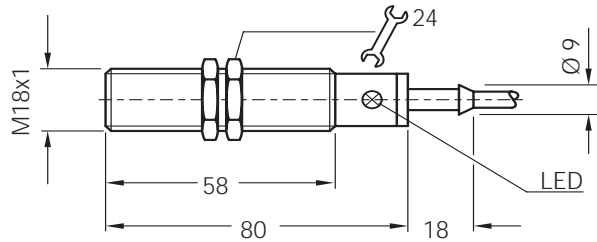
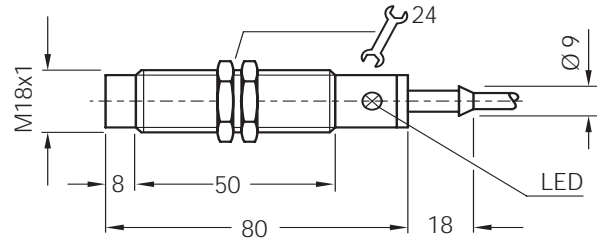

Features



- ▶ Can be installed flush or non-flush in metal
- ▶ Broad operating voltage range in AC and DC
- ▶ Normally open/ normally closed function
- ▶ High switching frequency
- ▶ Robust brass housing, nickel-plated, with fine thread M18 x 1 mm
- ▶ Enclosure rating IP 67
- ▶ LED status indicator

Accessories

Mounting bracket

Connection diagram

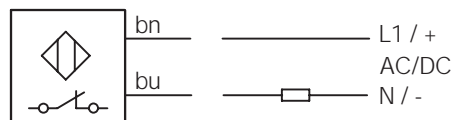
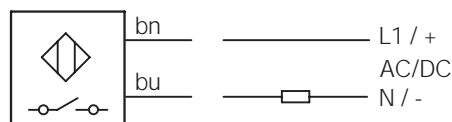









Wire colour	Assignment
bn	L1 / +
bu	N / -

Electrical and mechanical data

Operating voltage U_b	20 ... 250 V AC / DC	Wire-break protection	-
Voltage drop U_d (at I_a max.)	≤ 6.5 V AC / ≤ 6 V DC	Short-circuit protection (pulsed)	-
Continuous current I_a	≤ 350 mA AC (... + 50 °C) ≤ 250 mA AC (... + 80 °C) ≤ 100 mA DC	Reverse polarity protection	-
Peak current I_k	2.2 A (20ms/0.5 Hz)	Power-up pulse suppression	yes
Min. load current	5 mA	Enclosure rating to EN 60529	IP 67
Residual current	≤ 2.5 mA (250 V AC) ≤ 1.3 mA (110 V AC) ≤ 0.8 mA (24 V DC)	Protection class	
Time delay before availability t_v	approx. 8 ms	Shock and vibration stress	30 g, 11 ms 10 to 55 Hz, 1 mm
Hysteresis H	1% - 15% of s_r	Ambient temperature T_a	- 25 ... + 80 °C
Repeatability R (U_b and T_a constant)	$\leq 10\%$ of s_r	Housing material	Brass, nickel-plated, plastic
Temperature drift	$\pm 10\%$ of s_r	Tightening torque	35 Nm
EMC	to EN 60 947-5-2	Connection cable	PUR-PVC, 2 x 0.5 mm ²

Selection table

Sensing range s_n mm	Installation in metal	Output function	Switching frequency f in Hz	Connection	Type	Order number
5			25 (AC) / 100 (DC)	Cable 2 m	IM18-05BUS-ZU0	7902122
5			25 (AC) / 100 (DC)	Cable 2 m	IM18-05BUO-ZU0	7902123
8			25 (AC) / 100 (DC)	Cable 2 m	IM18-08NUS-ZU0	7902124
8			25 (AC) / 100 (DC)	Cable 2 m	IM18-08NUO-ZU0	7902125

Inductive proximity sensors

IM 30 series, sensing range 10 / 15 mm

AC / DC 2-wire, metal housing

Dimensions in mm

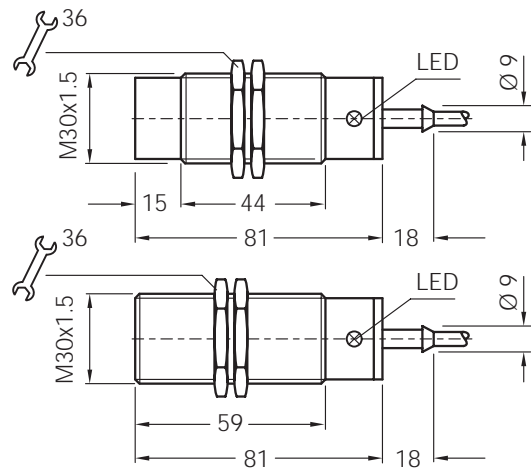

Features



- ▶ Can be installed flush or non-flush in metal
- ▶ Broad operating voltage range in AC and DC
- ▶ Normally open/ normally closed function
- ▶ Robust brass housing, nickel-plated, with fine thread M30 x 1.5 mm
- ▶ Enclosure rating IP 67
- ▶ LED status indicator

Accessories

Mounting bracket

Connection diagram

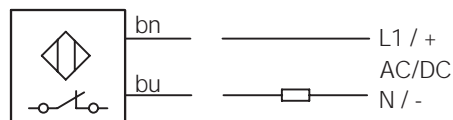
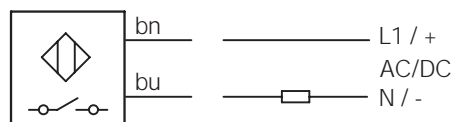

Wire colour	Assignment
bn	brown L1 / +
bu	blue N / -

Electrical and mechanical data

Operating voltage U_b	20 ... 250 V AC / DC	Wire-break protection	-
Voltage drop U_d (at I_a max.)	≤ 6.5 V AC / ≤ 6 V DC	Short-circuit protection (pulsed)	-
Continuous current I_a	≤ 350 mA AC (... + 50 °C) ≤ 250 mA AC (... + 80 °C) ≤ 100 mA DC	Reverse polarity protection	-
Peak current I_k	2.2 A (20ms/0.5 Hz)	Power-up pulse suppression	yes
Min. load current	5 mA	Enclosure rating to EN 60529	IP 67
Residual current	≤ 2.5 mA (250 V AC) ≤ 1.3 mA (110 V AC) ≤ 0.8 mA (24 V DC)	Protection class	□
Time delay before availability t_v	approx. 8 ms	Shock and vibration stress	30 g, 11 ms 10 to 55 Hz, 1 mm
Hysteresis H	1% - 15% of s_r	Ambient temperature T_a	- 25 ... + 80 °C
Repeatability R (U_b and T_a constant)	$\leq 10\%$ of s_r	Housing material	Brass, nickel-plated, plastic
Temperature drift	$\pm 10\%$ of s_r	Tightening torque	50 Nm
EMC	to EN 60 947-5-2	Connection cable	PUR-PVC, 2 x 0.5 mm ²

Selection table

Sensing range s_n mm	Installation in metal	Output function	Switching frequency f in Hz	Connection	Type	Order number
10			25 (AC) / 30 (DC)	Cable 2 m	IM30-10BUS-ZU0	7902126
10			25 (AC) / 30 (DC)	Cable 2 m	IM30-10BUO-ZU0	7902127
15			25 (AC) / 30 (DC)	Cable 2 m	IM30-15NUS-ZU0	7902128
15			25 (AC) / 30 (DC)	Cable 2 m	IM30-15NUO-ZU0	7902129



Inductive proximity sensors

IH 20 series, sensing range 10 mm

AC / DC 2-wire, plastic housing

Dimensions in mm

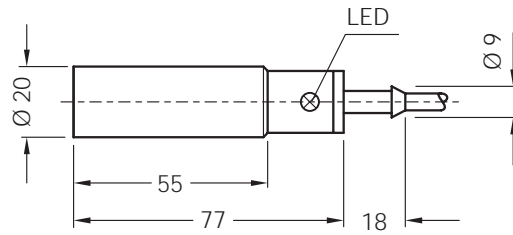

Features



- ▶ Can be installed non-flush in metal
- ▶ Broad operating voltage range in AC and DC
- ▶ Normally open function
- ▶ Plastic housing
- ▶ Enclosure rating IP 67
- ▶ LED status indicator

Accessories

- ▶ Mounting clamps incl.

Connection diagram

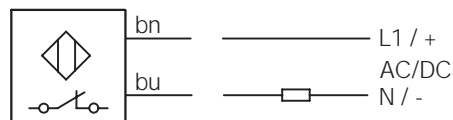
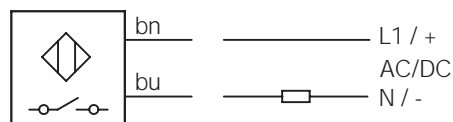



Wire colour	Assignment
bn brown	L1 / +
bu blue	N / -

Electrical and mechanical data

Operating voltage U_b	20 ... 250 V AC / DC	Wire-break protection	-
Voltage drop U_d (at I_a max.)	≤ 6.5 V AC / ≤ 6 V DC	Short-circuit protection (pulsed)	-
Continuous current I_a	≤ 350 mA AC (... + 50 °C) ≤ 100 mA DC	Reverse polarity protection	-
Peak current I_k	2.2 A (20ms/0.5 Hz)	Power-up pulse suppression	yes
Min. load current	5 mA	Enclosure rating to EN 60529	IP 67
Residual current	≤ 2.5 mA (250 V AC) ≤ 1.3 mA (110 V AC) ≤ 0.8 mA (24 V DC)	Protection class	<input type="checkbox"/>
Time delay before availability t_v	approx. 45 ms	Shock and vibration stress	30 g, 11 ms 10 to 55 Hz, 1 mm
Hysteresis H	1% - 15% of s_r	Ambient temperature T_a	- 25 ... + 80 °C
Repeatability R (U_b and T_a constant)	$\leq 10\%$ of s_r	Housing material	Plastic
Temperature drift	$\pm 10\%$ of s_r	Connection cable	PUR-PVC, 2 x 0.5 mm ²
EMC	to EN 60 947-5-2		

Selection table

Sensing range s_n mm	Installation in metal	Output function	Switching frequency f in Hz	Connection	Type	Order number
10			25 (AC) / 70 (DC)	Cable 2 m	IH20-10NUS-KU0	7902130



Inductive proximity sensors

IH 34 series, sensing range 30 mm

AC / DC 2-wire, plastic housing

Dimensions in mm

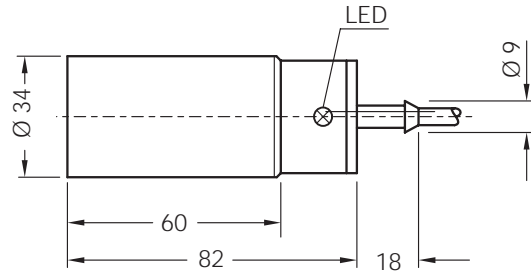

Features



- ▶ Can be installed non-flush in metal
- ▶ Enhanced sensing range
- ▶ Broad operating voltage range in AC and DC
- ▶ Normally open/ normally closed function
- ▶ Plastic housing
- ▶ Enclosure rating IP 67
- ▶ LED status indicator

Accessories

- ▶ Mounting clamps incl.

Connection diagram

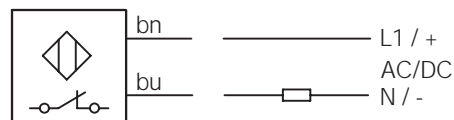
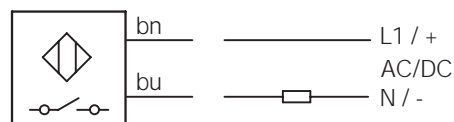

Wire colour	Assignment
bn brown	L1 / +
bu blue	N / -

Electrical and mechanical data

Operating voltage U_b	20 ... 250 V AC / DC	Wire-break protection	-
Voltage drop U_d (at I_a max.)	≤ 6.5 V AC / ≤ 6 V DC	Short-circuit protection (pulsed)	-
Continuous current I_a	≤ 350 mA AC (... + 50 °C) ≤ 250 mA AC (... + 80 °C) ≤ 100 mA DC	Reverse polarity protection	-
Peak current I_k	2.2 A (20ms / 0.5 Hz)	Power-up pulse suppression	yes
Min. load current	5 mA	Enclosure rating to EN 60529	IP 67
Residual current	≤ 2.5 mA (250 V AC) ≤ 1.3 mA (110 V AC) ≤ 0.8 mA (24 V DC)	Protection class	□
Time delay before availability t_v (with s_n 20 / 30 mm)	approx. 8 / 50 ms	Shock and vibration stress	30 g, 11 ms 10 to 55 Hz, 1 mm
Hysteresis H	1% - 15% of s_r	Ambient temperature T_a	- 25 ... + 80 °C
Repeatability R (U_b and T_a constant)	$\leq 10\%$ of s_r	Housing material	Plastic
Temperature drift	$\pm 10\%$ of s_r	Connection cable	PUR-PVC, 2 x 0.5 mm ²
EMC	to EN 60 947-5-2		

Selection table

Sensing range s_n mm	Installation in metal	Output function	Switching frequency f in Hz	Connection	Type	Order number
30			7	Cable 2 m	IH34-30NUS-KU0	7902134
30			7	Cable 2 m	IH34-30NUO-KU0	7902135

Inductive proximity sensors

IQ 40 series, sensing range 15 / 20 mm

AC / DC 2-wire, plastic housing

Dimensions in mm

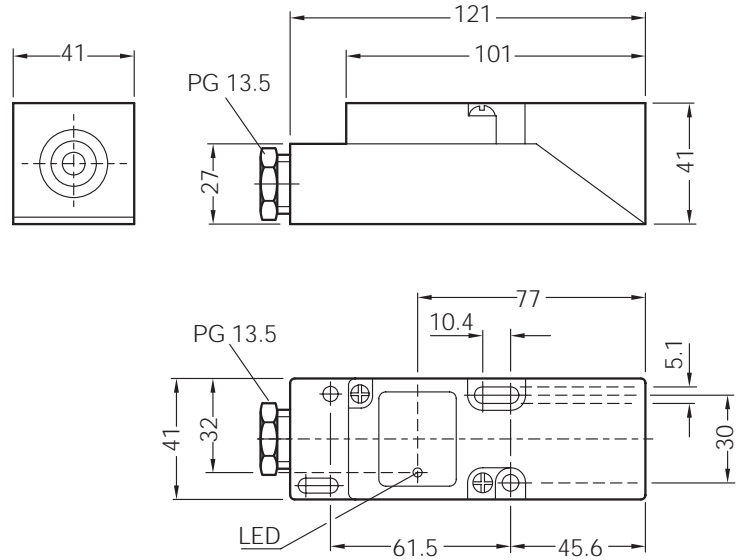

Features



- ▶ Can be installed flush or non-flush in metal
- ▶ Variable switching zone
- ▶ Broad operating voltage range in AC and DC
- ▶ Programmable switching output: NO or NC
- ▶ Plastic housing
- ▶ Enclosure rating IP 65
- ▶ Terminal connection
- ▶ LED status indicator

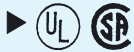

Connection diagram

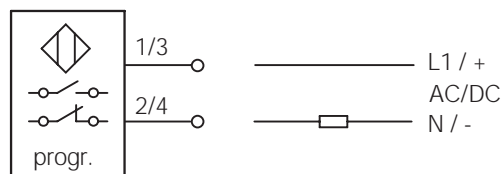



Programming with wire links
 Link closed: NO
 Link open: NC

Terminal	Assignment
1/3	L1 / +
2/4	N / -

Electrical and mechanical data

Operating voltage U_b	20 ... 250 V AC / DC	Wire-break protection	-
Voltage drop U_d (at I_a max.)	≤ 6.5 V AC / ≤ 6 V DC	Short-circuit protection (pulsed)	-
Continuous current I_a	≤ 350 mA AC (... + 50 °C) ≤ 250 mA AC (... + 80 °C) ≤ 100 mA DC	Reverse polarity protection	-
Peak current I_k	2.2 A (20 ms / 0.5 Hz)	Power-up pulse suppression	yes
Min. load current	5 mA	Enclosure rating to EN 60529	IP 65
Residual current	≤ 2.5 mA (250 V AC) ≤ 1.3 mA (110 V AC) ≤ 0.8 mA (24 V DC)	Protection class	
Time delay before availability t_v	approx. 8 ms	Shock and vibration stress	30 g, 11 ms 10 to 55 Hz, 1 mm
Hysteresis H	1% - 15% of s_r	Ambient temperature T_a	- 25 ... + 80 °C
Repeatability R (U_b and T_a constant)	$\leq 10\%$ of s_r	Housing material	Plastic
Temperature drift	$\pm 10\%$ of s_r		
EMC	to EN 60 947-5-2		

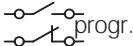
Selection table

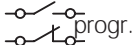
Sensing range s_n mm	Installation in metal	Output function	Switching frequency f in Hz	Connection	Type	Order number
15			20 (AC) / 55 (DC)	Terminal up to 2.5 mm ²	IQ40-15BUP-KK0	7902136
20			20 (AC) / 55 (DC)	Terminal up to 2.5 mm ²	IQ40-20NUP-KK0	7902137

Inductive proximity sensors

IQ 80 series, sensing range 60 mm

AC / DC 2-wire, plastic housing

Dimensions in mm

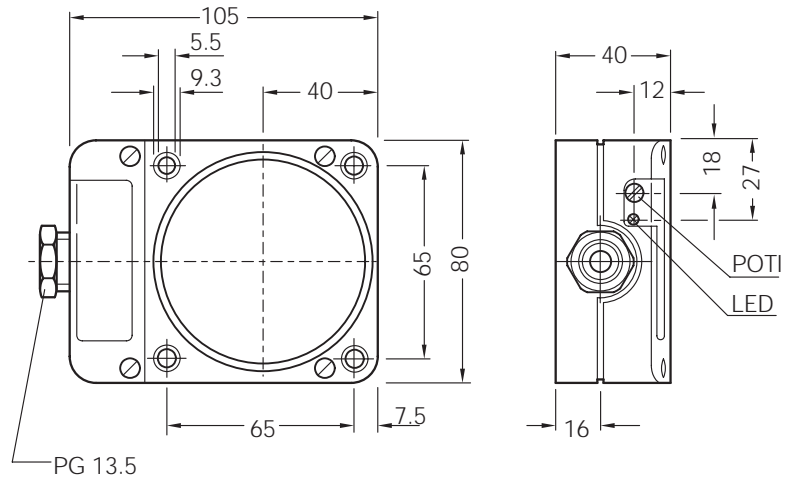
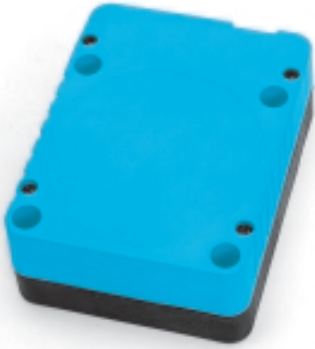

Features



- ▶ Can be installed non-flush in metal
- ▶ Adjustable switching distance between 20 and 60 mm
- ▶ Broad operating voltage range in AC and DC
- ▶ Programmable switching output: NO or NC
- ▶ Robust plastic housing
- ▶ Enclosure rating IP 65
- ▶ Terminal connection
- ▶ LED status indicator



Connection diagram

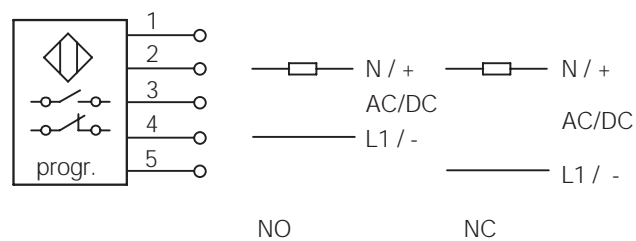

Terminal	Assignment
1	free
2	N / +
3	free
4	L1 / - (NO)
5	L1 / - (NC)

Electrical and mechanical data

Operating voltage U_b	20 ... 250 V AC / DC	Wire-break protection	-
Voltage drop U_d (at I_a max.)	≤ 6.5 V AC / ≤ 6 V DC	Short-circuit protection (pulsed)	-
Continuous current I_a	≤ 350 mA AC (... + 50 °C) ≤ 100 mA DC	Reverse polarity protection	-
Peak current I_k	2.2 A (20 ms / 0.5 Hz)	Power-up pulse suppression	yes
Min. load current	5 mA	Enclosure rating to EN 60529	IP 65
Residual current	≤ 2.5 mA (250 V AC) ≤ 1 mA (24 V DC)	Protection class	□
Time delay before availability t_v	approx. 8 ms	Shock and vibration stress	30 g, 11 ms 10 to 55 Hz, 1 mm
Hysteresis H	1% - 15% of s_r	Ambient temperature T_a	- 25 ... + 80 °C
Repeatability R (U_b and T_a constant)	$\leq 10\%$ of s_r	Housing material	Plastic
Temperature drift	$\pm 10\%$ of s_r		
EMC	to EN 60 947-5-2		

Selection table

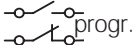
Sensing range s_n mm	Installation in metal	Output function	Switching frequency f in Hz	Connection	Type	Order number
60			4	Terminal up to 2.5 mm ²	IQ80-60NUP-KK0	7902138

Inductive proximity sensors

IM 08 series, sensing range 1 mm

NAMUR, metal housing

Dimensions in mm

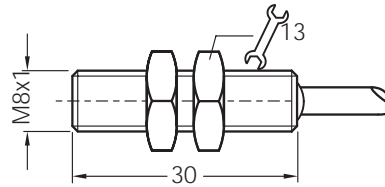

Features



- ▶ Can be installed flush in metal
- ▶ NAMUR to EN 50227
- ▶ High switching frequency
- ▶ Robust brass housing, nickel-plated, with fine thread M8 x 1 mm
- ▶ Enclosure rating IP 67
- ▶ **PTB classification for division 1 areas**
EEx ib IIC T6

Accessories

Isolating unit EN2Ex

Connection diagram

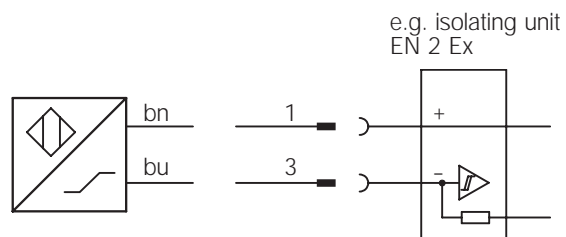



Wire colour			Assignment
bn	braun	brown	+ V DC
bu	blau	blue	- V DC

Electrical and mechanical data

Operating voltage U_b	5 ... 25 V DC	Enclosure rating to EN 60529	IP 67
Nominal voltage U_n	8.2 V DC	Shock and vibration stress	30 g, 11 ms 10 to 55 Hz, 1 mm
Power consumption, attenuated	≤ 1.0 mA	Ambient temperature T_a	- 25 ... + 70 °C
Power consumption, unattenuated	≥ 2.2 mA	Housing material	Brass, nickel-plated, plastic
Internal capacitance	≤ 80 nF	Tightening torque	2.5 Nm
Internal inductance	≤ 110 μ H	Connection cable	PVC, 2 x 0.14 mm ² , blue
Cable resistance	≤ 50 Ω		
Temperature drift	$\pm 10\%$ of s_r		
EMC	to EN 60 947-5-2		

Selection table

Sensing range s_n mm	Installation in metal	Version	Output function	Switching frequency f in Hz	Connection	Type	Order number
1		NAMUR		2000	Cable 2 m	IM08-01B-N-ZW0	6021123

Inductive proximity sensors

IM 12 series, sensing range 2 / 4 mm

NAMUR, metal housing

Dimensions in mm

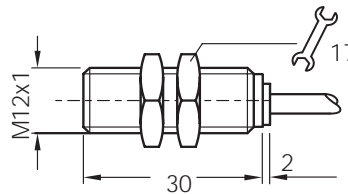
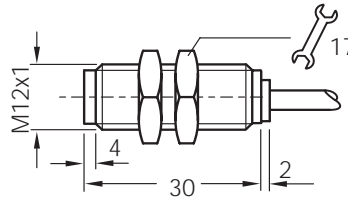

Features



- ▶ Can be installed flush or non-flush in metal
- ▶ NAMUR to EN 50227
- ▶ High switching frequency
- ▶ Robust brass housing, nickel-plated, with fine thread M12 x 1 mm
- ▶ Enclosure rating IP 67
- ▶ **PTB classification for division 1 areas**
- ▶ **Ex EEx ia IIC T6**

Accessories

Isolating unit EN2Ex
Mounting bracket

Connection diagram

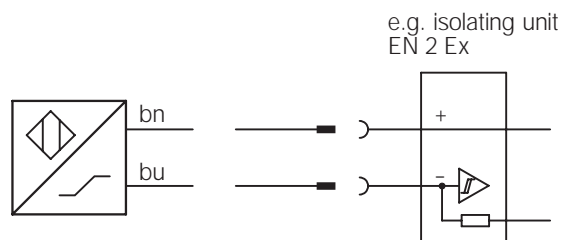





Wire colour			Assignment
bn	braun	brown	+ V DC
bu	blau	blue	- V DC

Electrical and mechanical data

Operating voltage U_b	5 ... 25 V DC	Short-circuit protected	yes
Rated voltage U_n	8.2 V DC	Reverse polarity protected	yes
Power consumption, attenuated	≤ 1.0 mA	Enclosure rating to EN 60529	IP 67
Power consumption, unattenuated	≥ 2.2 mA	Shock and vibration stress	30 g, 11 ms 10 to 55 Hz, 1 mm
Internal capacitance	≤ 230 nF	Ambient temperature T_a	- 25 ... + 70 °C
Internal inductance	≤ 380 μ H	Housing material	Brass, nickel-plated, plastic
Cable resistance	≤ 50 ω	Tightening torque	7.0 Nm
Temperature drift	$\pm 10\%$ of s_n	Connection cable	PVC, 2 x 0.34 mm ² , blue
EMC	to EN 60 947-5-2		

Selection table

Sensing range s_n mm	Installation in metal	Version	Output function	Switching frequency f in Hz	Connection	Type	Order number
2		NAMUR		1200	Cable 2 m	IM12-02B-N-ZW0	6021124
4		NAMUR		1500	Cable 2 m	IM12-04N-N-ZW0	6021125



Inductive proximity sensors

IM 18 series, sensing range 5 / 8 mm

NAMUR, metal housing

Dimensions in mm

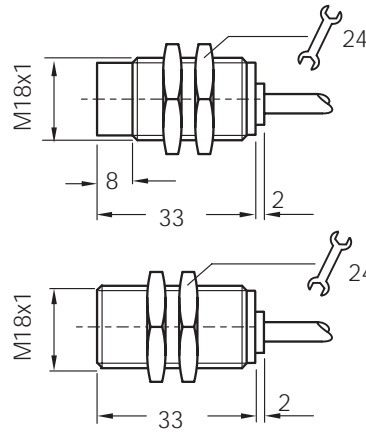

Features



- ▶ Can be installed flush or non-flush in metal
- ▶ NAMUR to EN 50227
- ▶ High switching frequency
- ▶ Robust brass housing, nickel-plated, with fine thread M18 x 1 mm
- ▶ Enclosure rating IP 67
- ▶ **PTB classification for division 1 areas**
Ex EEx ia IIC T6

Accessories

Isolating unit EN2Ex
 Mounting bracket

Connection diagram

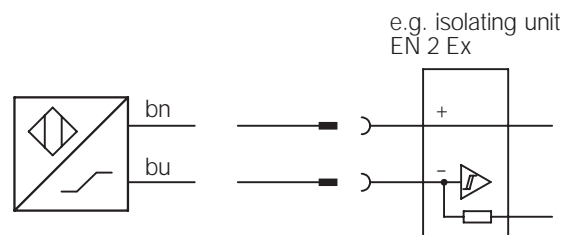





Wire colour			Assignment
bn	braun	brown	+ V DC
bu	blau	blue	- V DC

Electrical and mechanical data

Operating voltage U_b	5 ... 25 V DC	Short-circuit protected	yes
Rated voltage U_n	8.2 V DC	Reverse polarity protected	yes
Power consumption, attenuated	≤ 1.0 mA	Enclosure rating to EN 60529	IP 67
Power consumption, unattenuated	≥ 2.2 mA	Shock and vibration stress	30 g, 11 ms 10 to 55 Hz, 1 mm
Internal capacitance	≤ 230 nF (flush) ≤ 240 nF (non-flush)	Ambient temperature T_a	- 25 ... + 70 °C
Internal inductance	≤ 60 μ H	Housing material	Brass, nickel-plated, plastic
Cable resistance	≤ 50 ω	Tightening torque	35 Nm
Temperature drift	$\pm 10\%$ of s_r	Connection cable	PVC, 2 x 0.34 mm ² , blue
EMC	to EN 60 947-5-2		

Selection table

Sensing range s_n mm	Installation in metal	Version	Output function	Switching frequency f in Hz	Connection	Type	Order number
5		NAMUR		720	Cable 2 m	IM18-05B-N-ZW0	6021126
8		NAMUR		300	Cable 2 m	IM18-08N-N-ZW0	6021127

Inductive proximity sensors

IM 30 series, sensing range 10 / 15 mm

NAMUR, metal housing

Dimensions in mm

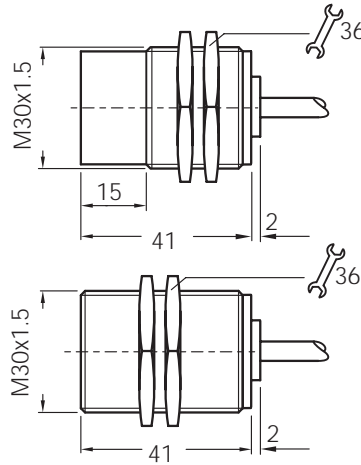

Features



- ▶ Can be installed flush or non-flush in metal
- ▶ NAMUR to EN 50227
- ▶ High switching frequency
- ▶ Robust brass housing, nickel-plated, with fine thread M30 x 1.5 mm
- ▶ Enclosure rating IP 67
- ▶ **PTB classification for division 1 areas**
EEx ia IIC T6

Accessories

Isolating unit EN2Ex
 Mounting bracket

Connection diagram

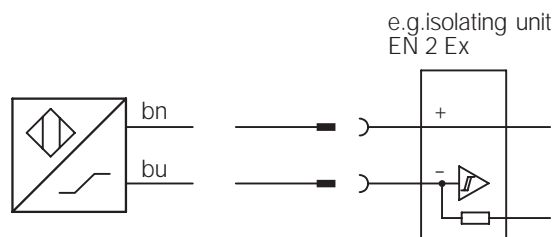





Wire colour			Assignment
bn	braun	brown	+ V DC
bu	blau	blue	- V DC

Electrical and mechanical data

Operating voltage U_b	5 ... 25 V DC	Short-circuit protected	yes
Rated voltage U_n	8.2 V DC	Reverse polarity protected	yes
Power consumption, attenuated	≤ 1.0 mA	Enclosure rating to EN 60529	IP 67
Power consumption, unattenuated	≥ 2.2 mA	Shock and vibration stress	30 g, 11 ms 10 to 55 Hz, 1 mm
Internal capacitance	≤ 230 nF (flush) ≤ 240 nF (non-flush)	Ambient temperature T_a	- 25 ... + 70 °C
Internal inductance	≤ 130 μ H (flush) ≤ 100 μ H (non-flush)	Housing material	Brass, nickel-plated, plastic
Cable resistance	≤ 50 Ω	Tightening torque	50 Nm
Temperature drift	$\pm 10\%$ of s_r	Connection cable	PVC, 2 x 0.5 mm ² , blue
EMC	to EN 60 947-5-2		

Selection table

Sensing range s_n mm	Installation in metal	Version	Output function	Switching frequency f in Hz	Connection	Type	Order number
10		NAMUR		450	Cable 2 m	IM30-10B-N-ZW0	6021128
15		NAMUR		200	Cable 2 m	IM30-15N-N-ZW0	6021129

Operating Principle

Capacitive proximity sensors

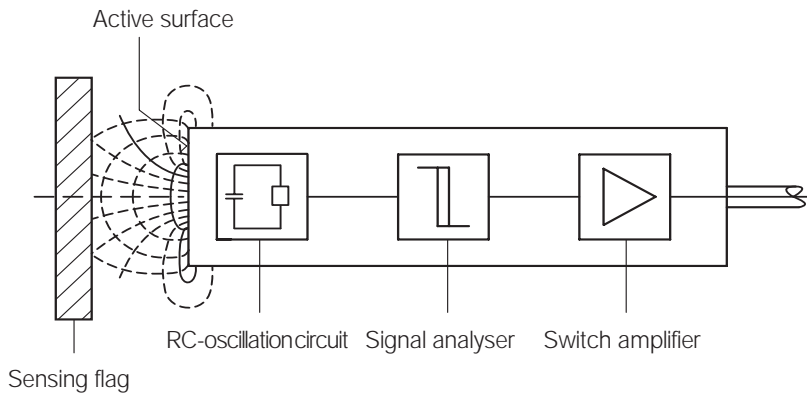

The active element in a capacitive proximity sensor consists of a sensor electrode and shielding. Together, these two electrodes form the capacitor. On the approach of a sensing flag (metallic or non-metallic object), a

change in capacity takes place in the electrical field of this capacitor, i.e. the capacitor of the RC oscillation circuit is arranged in such a way that its capacity increases when an object approaches.

The oscillator is set in such a way that it only becomes capable of oscillation through this increase in capacity. The start in oscillation when an object approaches is detected by the signal analyser and output via the signal amplifier.

Reduction factor R

As with the inductive proximity sensors, the reduction factor depends on the material. It describes the factor by which the sensing range s is reduced by a certain material, with reference to the nominal sensing range s_n , which results from the use of an earthed ST37 metal plate as sensing flag.

The most important reduction factors for capacitive proximity sensors are:

iron, earthed	1.0
water	1.0
wheat	0.
(moisture content 12%)	
wood	0.7
glass	0.6
oil	0.4
PVC	0.4
PE	0.37
ceramic material	0.3

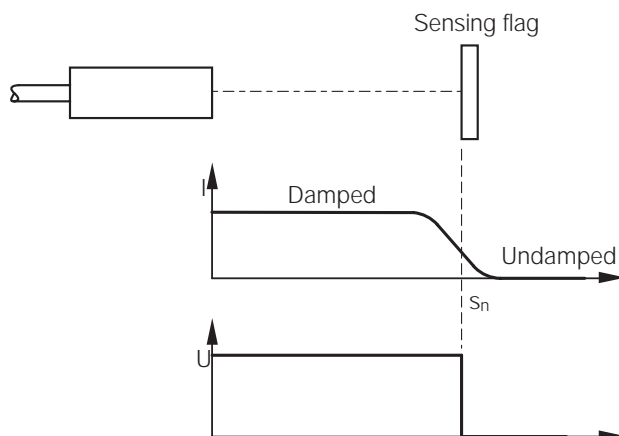

EMC-overview

Test	Standard	Product Standard EN 60947-5-2	Generic Standard EN 50082-2	SICK Capacitive Sensors
Electrostatic Discharge ESD	EN 61000-4-2 (IEC 1000-4-2)	4 kV cd / 8 kV ad*	4 kV cd/8 kV ad*	17 kV cd/ad*
HF radiated	EN 61000-4-3 (IEC 1000-4-3)	3 V/m 80 ... 1000 MHz	10 V/m 80 ... 1000 MHz	< 15 V/m 80 ... 1000 MHz
HF wire conducted	EN 61000-4-6 (IEC 1000-4-6)	-	10 V 0,15 ... 80 MHz	> 10 V
Burst	EN 61000-4-4 (IEC 1000-4-4)	1 kV	2 kV	4 kV
Surge	IEC 255-5	1 kV, 500 Ohm	-	2.5 kV, 500 Ohm

*cd = contact discharge ad = air discharge

Selection table/Type code

Capacitive proximity sensors

Series	Housing			Sensing range s _n in mm		Switching output	Outout function	Connection type		Electr. config.	Page
	Design	Size in mm	Material	Flush	N. flush	PNP	complementary	Cable	Connector		
CM18	with thread	M18	Plastic	8	12	•	•	•	•	DC	108
CM30		M30	Plastic	16	25	•	•	•	•	DC	110
CQ35	Cuboid	35x55x15	Plastic	16	25	•	•	•	•	DC	112

Character	1	2	3	4	5	6	7	8	9	10	11	12	13	14	Stelle	
	C	M	3	O	-	2	5	N	P	P	-	K	W	O		
1 Sensor technologie C Capacitive														other codes	14	
2 Design M Cylinder with thread Q Cuboid														Connection W Cable, PVC C Connector, M12x1	13	
3/4 Housing shape 18 Diameter 30 or 35 Edge length of sensing face														Housing material K Plastic	12	
6/7/8 Sensing range/ installation B flush N non flush 08B 8 mm; flush 25N 25 mm; non flush														Output P complementary	10	
															Interface P DC (3/4-wire) PNP N DC (3/4-wire) NPN	9

Capacitive proximity sensors

CM18 series, sensing range 8 / 12 mm

DC 4-wire, plastic housing

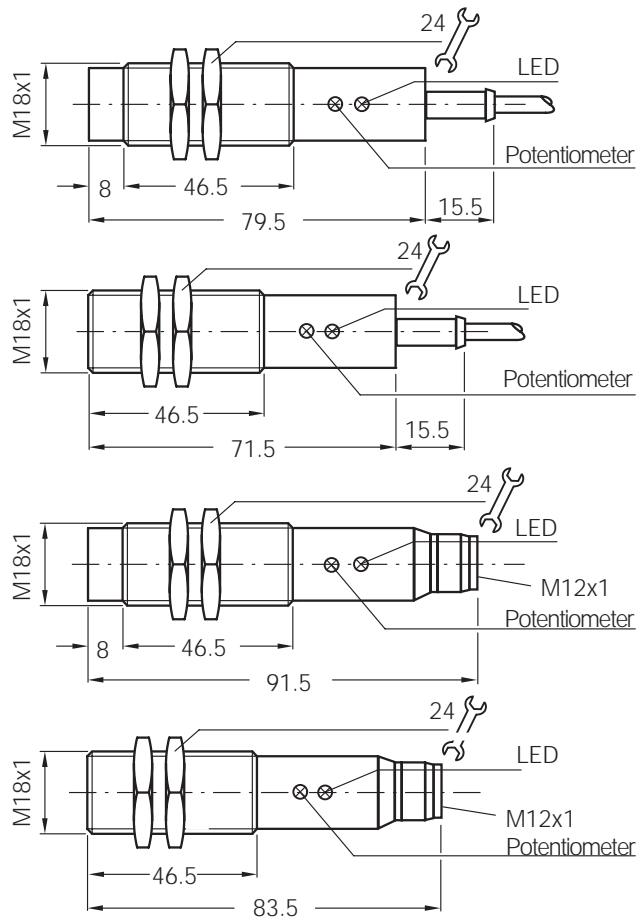

Features



- ▶ High EMC-immunity
- ▶ Can be installed flush or non-flush
- ▶ PNP output
- ▶ Adjustable sensing range: 3 to 8 mm (flush), 3 to 12 mm (non flush)
- ▶ Complementary output function
- ▶ Short-circuit protection (pulsed)
- ▶ Plastic housing with fine thread M18 x 1 mm
- ▶ Cable or connector
- ▶ Enclosure rating IP 67
- ▶ LED-status indicator
- ▶

Accessories

- Round connector
- Mounting bracket

Connection diagram

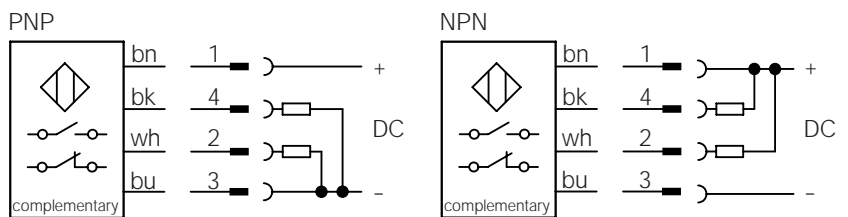



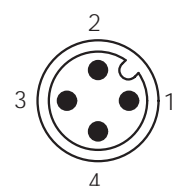













Wire colour	Contact	Assignment
bn brown	1	+ V DC
bk black	4	Schließer
wh white	2	Öffner
bu blue	3	- V DC



Electrical and mechanical data

Operating voltage U_b	10 ... 40 V DC	Short circuit protection (pulsed)	yes
Ripple U_{pp}	$\leq 10\%$ of U_b	Reverse polarity protection	yes
Voltage drop U_d	$\leq 2,5$ V	Power-up pulse suppression	yes
Power consumption (without load)	≤ 10 mA	Enclosure rating to EN 60529	IP 67
Continuous current I_a	≤ 200 mA	Shock und vibration stress	30 g, 11 ms 10 to 55 Hz, 1 mm
Time delay before availability t_v	≤ 100 ms	Ambient temperature T_a	- 25 ... + 80 °C
Hysteresis H	4% ... 20% of s_r	Housing material	Plastic
Repeatability R (U_b and T_a constant)	$\leq 5\%$ of s_r	Tightening torque	2,6 Nm
Temperature drift	$\pm 10\%$ of s_r	Connection cable	PVC, 4 x 0.34 mm ²
EMV	to EN 60 947-5-2		

Selection table

Sensing range s_n mm	Installation	Switching output	Output function	Switching frequency f in Hz	Connection	Type	Order number
8		PNP	 complementary	30	cable 2 m	CM18-08BPP-KW1	6020136
8		NPN	 complementary	30	cable 2 m	CM18-08BNP-KW1	6021455
8		PNP	 complementary	30	connector M12 x 1 mm	CM18-08BPP-KC1	6020388
8		NPN	 complementary	30	connector M12 x 1 mm	CM18-08BNP-KC1	6021456
12		PNP	 complementary	30	cable 2 m	CM18-12NPP-KW1	6020389
12		NPN	 complementary	30	cable 2 m	CM18-12NNP-KW1	6021457
12		PNP	 complementary	30	connector M12 x 1 mm	CM18-12NPP-KC1	6020410
12		NPN	 complementary	30	connector M12 x 1 mm	CM18-12NNP-KC1	6021458

Capacitive proximity sensors

CM30 series, sensing range 16 / 25 mm

DC 4-wire, plastic housing

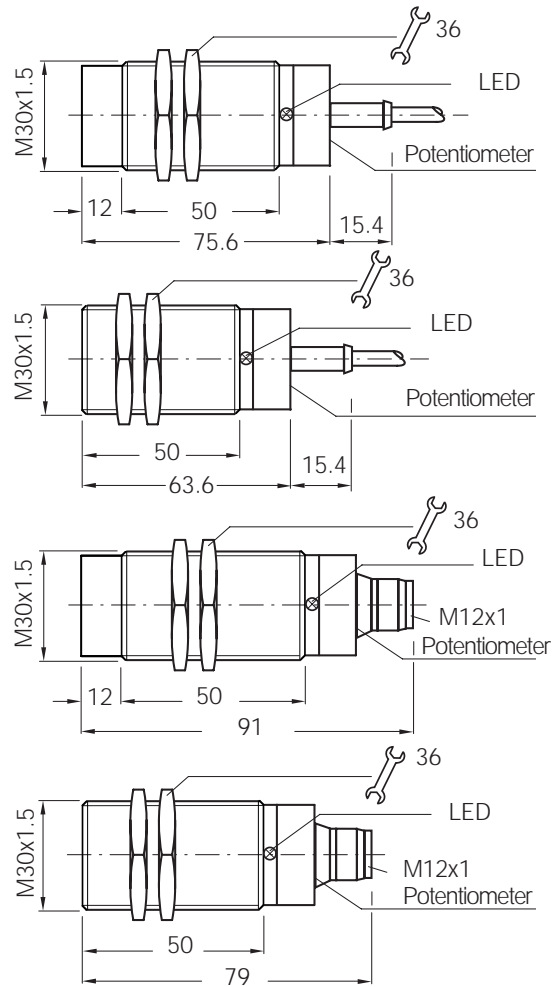

Features



- ▶ High EMC-immunity
- ▶ Can be installed flush or non-flush
- ▶ PNP output
- ▶ Adjustable sensing range: 2 to 16 mm (flush), 4 to 25 mm (non flush)
- ▶ Complementary output function
- ▶ Short-circuit protection (pulsed)
- ▶ Plastic housing with fine thread M30 x 1.5 mm
- ▶ Cable or connector
- ▶ Enclosure rating IP 67
- ▶ LED-status indicator
- ▶

Accessories

- Round connector
- Mounting bracket

Connection diagram

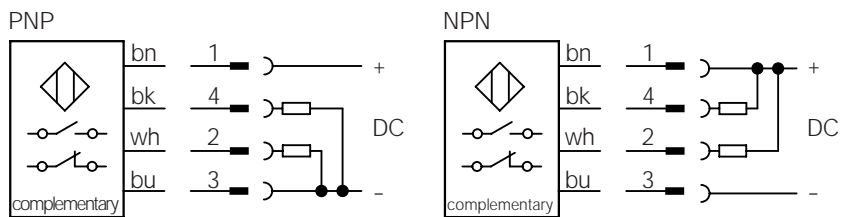



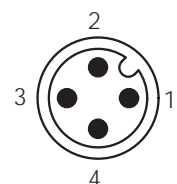











Wire colour	Contact	Assignment
bn brown	1	+ V DC
bk black	4	NO
wh white	2	NC
bu blue	3	- V DC



Electrical and mechanical data

Operating voltage U_b	10 ... 40 V DC	Short circuit protection (pulsed)	yes
Ripple U_{pp}	$\leq 10\%$ of U_b	Reverse polarity protection	yes
Voltage drop U_d	$\leq 2,5$ V	Power-up pulse suppression	yes
Power consumption (without load)	≤ 10 mA	Enclosure rating to EN 60529	IP 67
Continuous current I_a	≤ 200 mA	Shock und vibration stress	30 g, 11 ms 10 to 55 Hz, 1 mm
Time delay before availability t_v	≤ 100 ms	Ambient temperature T_a	- 25 ... + 80 °C
Hysteresis H	4% ... 20% of s_r	Housing material	Plastic
Repeatability R (U_b and T_a constant)	$\leq 5\%$ of s_r	Tightening torque	7,5 Nm
Temperature drift EMV	$\pm 10\%$ of s_r to EN 60 947-5-2	Connection cable	PVC, 4 x 0.34 mm ²

Selection table

Sensing range s_n mm	Installation	Switching output	Output function	Switching frequency f in Hz	Connection	Type	Order number
16		PNP	 complementary	50	cable 2 m	CM30-16BPP-KW1	6020473
16		NPN	 complementary	50	cable 2 m	CM30-16BNP-KW1	6021459
16		PNP	 complementary	50	connector M12 x 1 mm	CM30-16BPP-KC1	6020475
16		NPN	 complementary	50	connector M12 x 1 mm	CM30-16BNP-KC1	6021460
25		PNP	 complementary	50	cable 2 m	CM30-25NPP-KW1	6020476
25		NPN	 complementary	50	cable 2 m	CM30-25NNP-KW1	6021461
25		PNP	 complementary	50	connector M12 x 1 mm	CM30-25NPP-KC1	6020477
25		NPN	 complementary	50	connector M12 x 1 mm	CM30-25NNP-KC1	6021462

Capacitive proximity sensors

CQ35 series, sensing range 25 mm

DC 4-wire, plastic housing

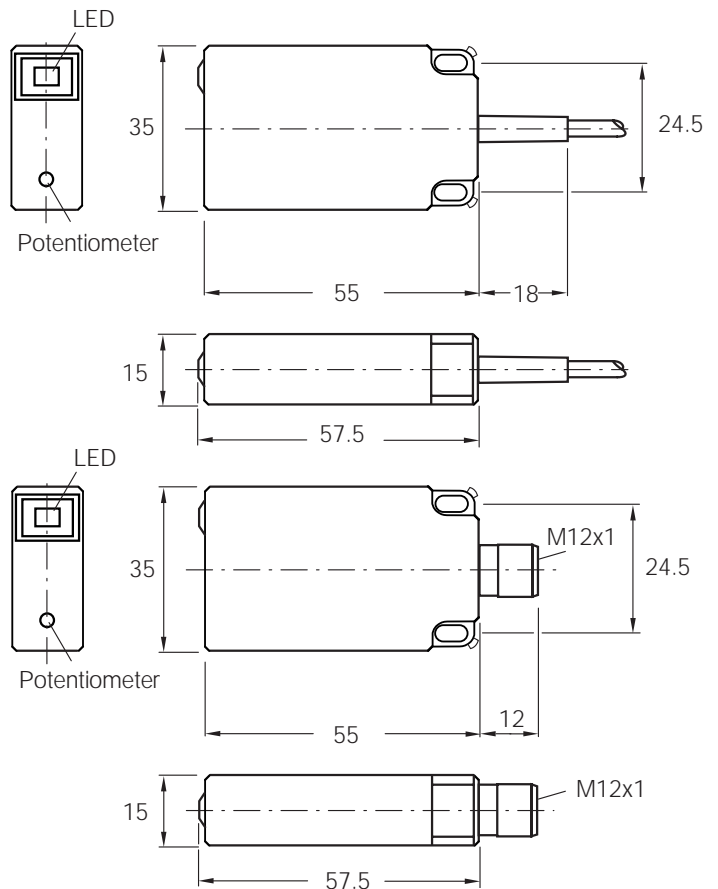

Features



- ▶ High EMC-immunity
- ▶ Can be installed flush or non-flush
- ▶ PNP output
- ▶ Adjustable sensing range: 4 to 25 mm (non flush)
- ▶ Device can be flush mounted, sensing range: 16 mm
- ▶ Complementary output function
- ▶ Short-circuit protection (pulsed)
- ▶ Plastic housing
- ▶ Cable or connector
- ▶ Enclosure rating IP 67
- ▶ LED-status indicator
- ▶

Accessories

Round connector

Connection diagram

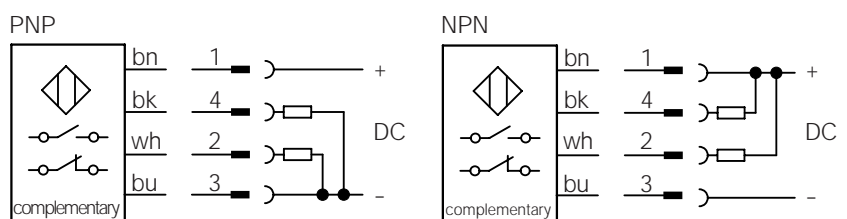



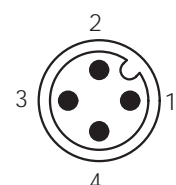





Wire colour	Contact	Assignment
bn brown	1	+ V DC
bk black	4	NO
wh white	2	NC
bu blue	3	- V DC



Electrical and mechanical data

Operating voltage U_b	10 ... 40 V DC	Short circuit protection (pulsed)	yes
Ripple U_{pp}	$\leq 10\%$ of U_b	Reverse polarity protection	yes
Voltage drop U_d	$\leq 2,5$ V	Power-up pulse suppression	yes
Power consumption (without load)	≤ 10 mA	Enclosure rating to EN 60529	IP 67
Continuous current I_a	≤ 200 mA	Shock and vibration stress	30 g, 11 ms 10 to 55 Hz, 1 mm
Time delay before availability t_v	≤ 100 ms	Ambient temperature T_a	- 25 ... + 75 °C
Hysteresis H	4% ... 20% of s_r	Housing material	Plastic
Repeatability R (U_b und T_a constant)	$\leq 5\%$ of s_r	Connection cable	PVC, 4 x 0.34 mm ²
Temperature drift EMV	$\pm 10\%$ of s_r to EN 60 947-5-2		

Selection table

Sensing range s_n mm	Installation	Switching output	Output function	Switching frequency f in Hz	Connection	Type	Order number
25		PNP	 complementary	50	cable 2 m	CQ35-25NPP-KW1	6020478
25		NPN	 complementary	50	cable 2 m	CQ35-25NNP-KW1	6021463
25		PNP	 complementary	50	connector M12 x 1 mm	CQ35-25NPP-KC1	6020479
25		NPN	 complementary	50	connector M12 x 1 mm	CQ35-25NNP-KC1	6021464

Operating Principle

Magnetic proximity sensors

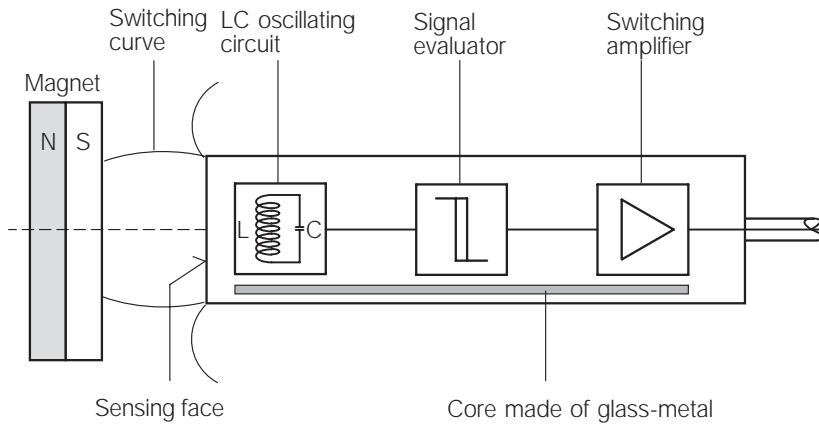

A major advantage of this technology is that large sensing ranges are possible even with small sensor types.

Permanent magnets are usually used to trigger magnetic proximity sensors. They comprise magnetically hard substances - steel alloyed with other metals such as aluminium, cobalt, and nickel. Magnetically hard ferrite with similar properties can also be produced from sintered compounds containing iron oxide and other metal oxides.

As with inductive proximity sensors, magnetic proximity sensors also have an LC oscillating circuit, a signal evaluator, and a switching amplifier. They also have a core (strip) made of amorphous, highly permeable, and magnetically soft glass-metal.

This strip attenuates the oscillating circuit using eddy-current losses. The core becomes magnetically saturated very quickly if a magnetic field is applied, e.g. if a magnet is brought

closer. The eddy-current losses attenuating the oscillating circuit are reduced and the oscillating de-attenuates. The power consumption of a magnetic proximity sensor therefore increases as a magnet is brought closer, in contrast to inductive proximity sensors where the oscillator current is reduced as the switching trigger is brought closer. For this reason, the starting curves are not the lines of an electromagnetic field, but "limit lines" which describe the saturation of the glass-metal strip by a magnet and the associated "switch-through" of the sensor.

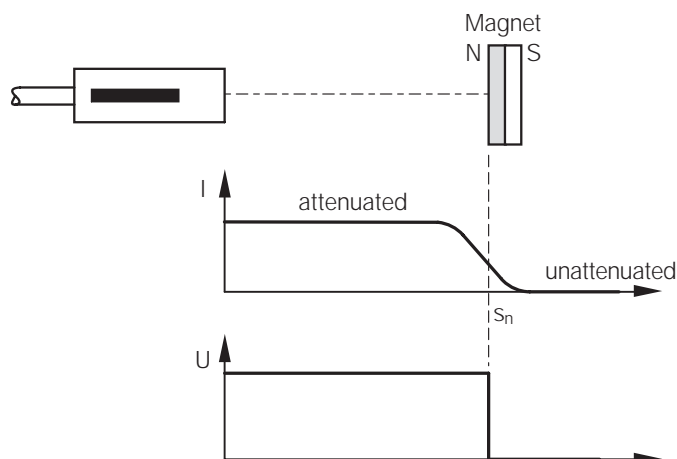

Glossary

Magnetic proximity sensors

Rated response sensitivity

The response sensitivity applies to both magnetic field poles without external field interference. In rooms and industrial plants, external magnetic fields are caused by the earth's magnetic field, electrical conductors, magnetic coils, permanent magnets, and steel objects containing residual magnetism. Neighbouring iron parts may increase external interference or have a shielding effect. External magnetic fields are usually constant or periodically effective and can therefore be taken into consideration. If necessary, magnetic shielding plates must be used or the sensors must be installed flush in the steel.

design	response sensitivity
MM08	1 mT
MM12	1 mT
MM18	0,9 mT
MQ10	1 mT

Magnetic induction

The illustration shows magnetic induction as a function of the distance to the actuating magnet. Electric coils or permanent magnets are used to adjust the response sensitivity of the sensors and also for comparative measurements. An oxide magnet made of barium ferrite with a 30 mm diameter and 10 mm in height (M4.0) is used as the standard measure.

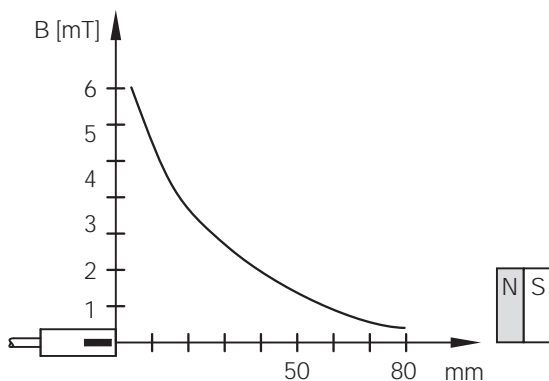

Approach curves

In the case of magnetic proximity sensors, it must be remembered that the alignment of the magnet relative to the sensor axis changes the sensing range. The lines of magnetic flux have to be in one line with the core of glass metal. A distinction can be made between the following cases:

Sensor and magnet axis are in alignment with each other.

Case 1

The sensor responds as soon as the magnet reaches the switching curve. It can approach the proximity sensor axially or pass in front of the sensor inside the sensing range.

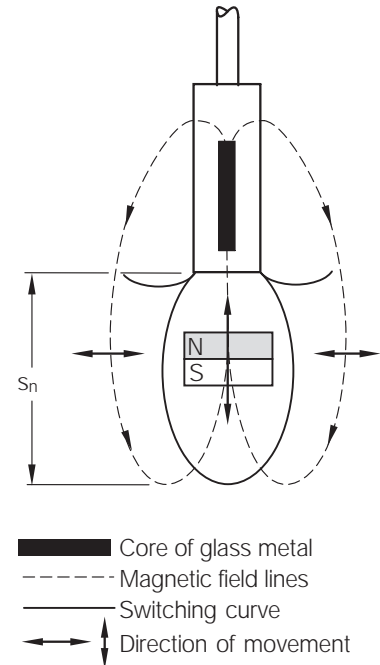

Case 2

The sensor responds if the magnet approaches the switching curve laterally. If the sensor leaves the switching curve, the sensor switches back again. This principle is largely used for magnetic cylinder sensors.

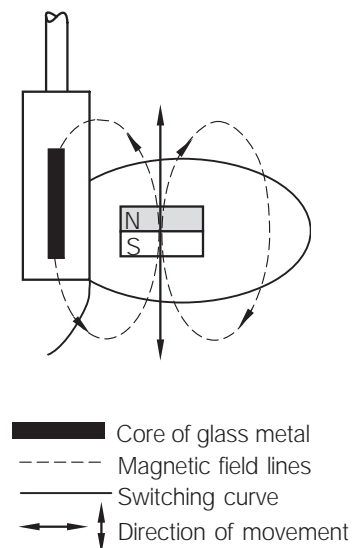

Glossary

Magnetic proximity sensors

Sensor and magnet axis are offset by 90°.

Case 3

If the magnet passes radially in front of the proximity sensor, the sensing range is smaller than that in the case 1. If, for example, the sensor enters the left-hand switching curve from the right-hand switching curve, it passes through an area in which the magnetic field is reversed. This briefly de-attenuates the proximity sensor before it is re-attenuated in the left-hand switching curve. Whether or not the evaluation unit can detect this interruption depends on the actuating speed and the axial distance of the traversing magnet.

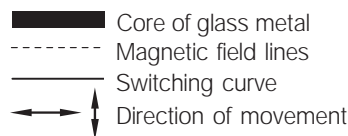
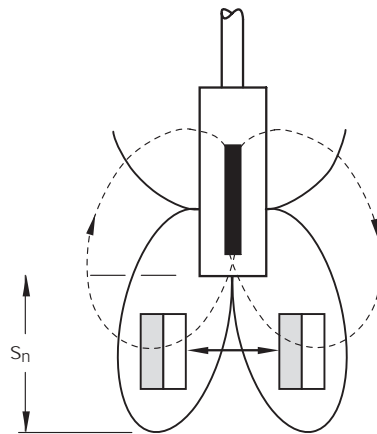

Case 4

In this case, the magnet passes through two switching curves. The magnetic field reverses at the boundary of these curves and two switching points are produced. The detection of this interruption again depends on the actuating speed and the radial distance relative to the sensor axis.

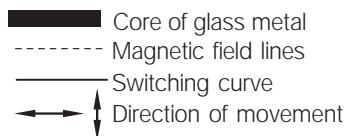
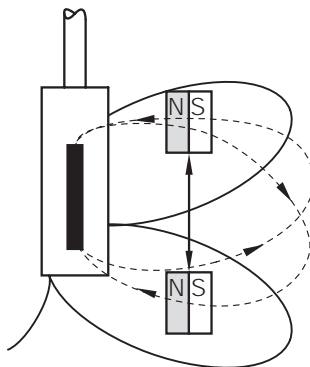

Traversal distance $S_{\bar{u}}$

The traversal distance $s_{\bar{u}}$ is the distance between the left- and right-hand boundary of the switching curve plus the diameter of the magnet. If a magnet approaches the switching curve from the left-hand side, the sensor responds. If the magnet leaves the switching curve at the opposite side, the sensor only switches if the magnet has completely left the envelope curve.

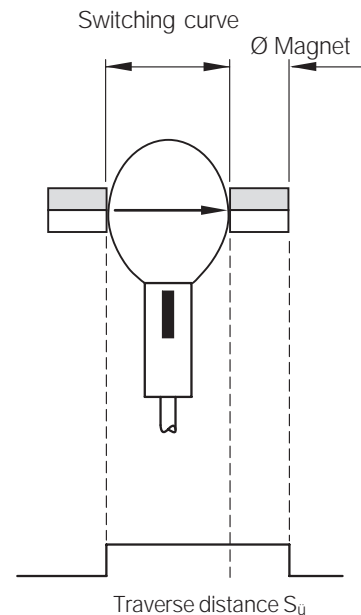

Traversal time $t_{\bar{u}}$

$$t_{\bar{u}} = \frac{S_{\bar{u}}}{v_{\bar{u}}}$$

$S_{\bar{u}}$ = Traversal distance

$v_{\bar{u}}$ = Traversal velocity

Sensing range and switching curves

The following tables show the sensing ranges s_n and switching curve diameter (s_D) relative to the actuating magnets (M1.0 - M5.0):

Series: MM08 - 60 A - ...
 MQ10 - 60 A - ...
 MM12 - 60 A - ...

Magnet type	S_n mm		s_{D1} mm	s_{D2} mm
	On	Off		
M 1.0	23	25	28	23
M 2.0	24	25	30	27
M 3.0	36	37	41	36
M 4.0	60	61	68	60
M 5.0	68	70	80	67

Series: MM18 - 70 A - ...

Magnet type	S_n mm		s_{D1} mm	s_{D2} mm
	On	Off		
M 1.0	24	25	30	26
M 2.0	25	26	36	32
M 3.0	38	39	45	40
M 4.0	70	72	75	65
M 5.0	85	87	86	75

The difference between S_n "ON" und S_n "OFF" describes the hysteresis of each sensor.

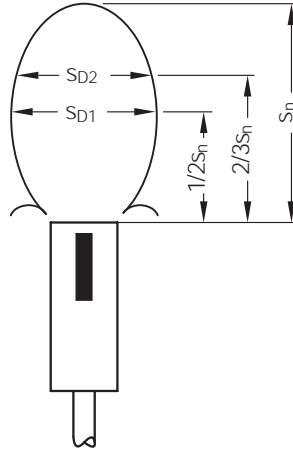

Magnet material

- M1.0 - Samarium cobalt (Ø 10 x 3 mm)
- M2.0 - AlNiCo (Ø 6 x 25 mm)
- M3.0 - Barium ferrite (Ø 20 x 6.5 mm)
- M4.0 - Barium ferrite (Ø 30 x 10 mm)
- M5.0/5.1 - Barium ferrite (Ø 30/35 x 15 mm)

The magnet M4.0 is used as the standard measure.

Installation Notes

Magnetic proximity sensors

Flush sensor installation

Magnetic proximity sensors can be installed flush in all materials and metals (with the exception of magnetizable material) without any detrimental effects to the sensing range.

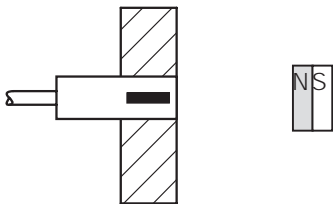

Flush magnet installation

The sensing range is reduced up to 60 % if the magnets are installed in magnetizable material.

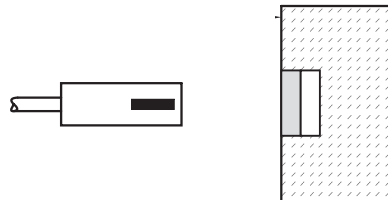

Penetration of material

Since magnetic fields do not penetrate all non-magnetizable material, magnetic proximity sensors can be used to detect magnets e.g. behind a non-ferrous metal, plastic, or wooden panel.

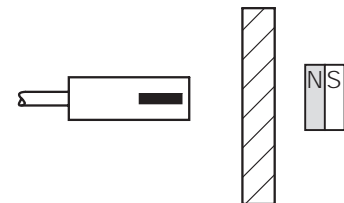

Non-flush sensor installation

The table shows how much the proximity sensor must protrude when installed in magnetizable material so that a reduction in sensing range of more than 5 % is avoided.

Mounting on magnetizable material

If the magnets are mounted on magnetizable material, the sensing range increases to the values printed in bold in the table below:

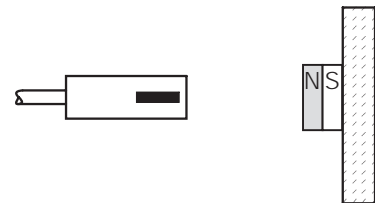

Standard measure M 4.0

Series	a = Free zone (mm)
MM08-60 A-...	10 mm
MM12-60 A-...	10 mm
MM18-70 A-...	15 mm
MQ10-60 A-...	10 mm

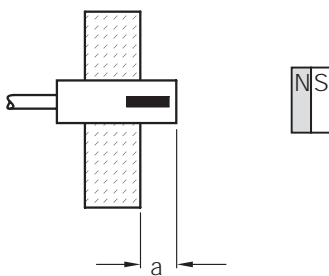

Series	Actuating magnets s_n mm				
	M 1.0	M 2.0	M 3.0	M 4.0	M 5.0
MM08-60 A-...	23 36	24 32	36 45	60 67	68 73
MM12-60 A-...	23 36	24 32	36 45	60 67	68 73
MM18-70 A-...	24 38	25 35	38 50	70 82	85 95
MQ10-60 A-...	23 36	24 32	36 45	60 67	68 73

Selection Table/Type Code

Magnetic proximity sensors

Series	Housing			Sensing range s_n in mm	Switching output		Output function NO	Connection		Electr. config.	Page
	Form	Size in mm	Material		PNP	NPN		Cable	Connector		
MM08	Cylinder	M8	Brass	60	•	•	•	•	•	DC	120
MM12	with thread	M12	Brass	60	•	•	•	•	•	DC	122
MM18		M18	Brass	70	•	•	•	•	•	DC	124
MQ10	Cuboid	10x28/37x16	Plastic	60	•	•	•	•	•	DC	126
MM12	Cylinder	M12	Brass	60				•	•	NAMUR	128
MM18	with thread	M18	Brass	70				•	•	NAMUR	130

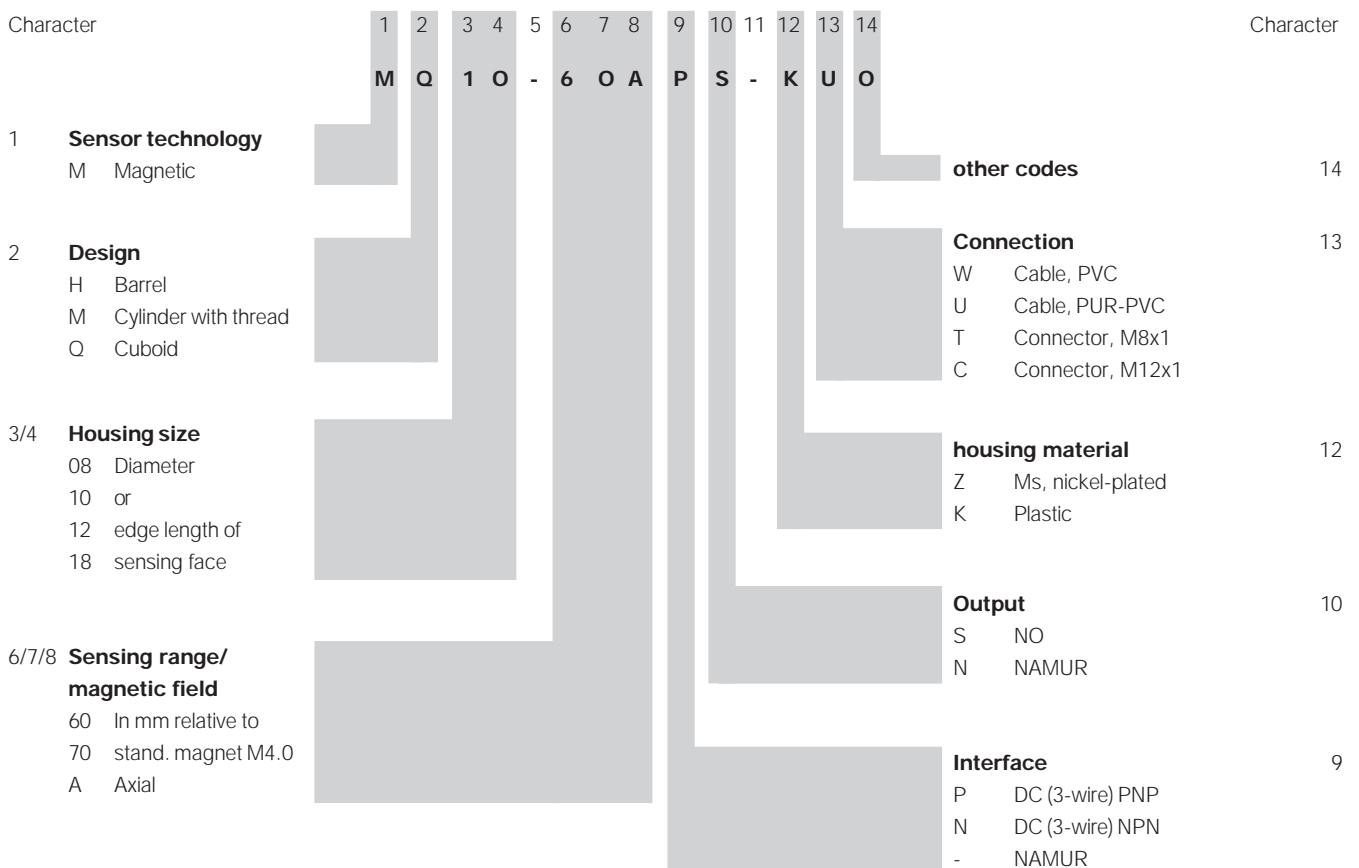



Magnetic proximity sensors

MM 08 series, sensing range 60 mm

DC 3-wire, metal housing

Dimensions in mm

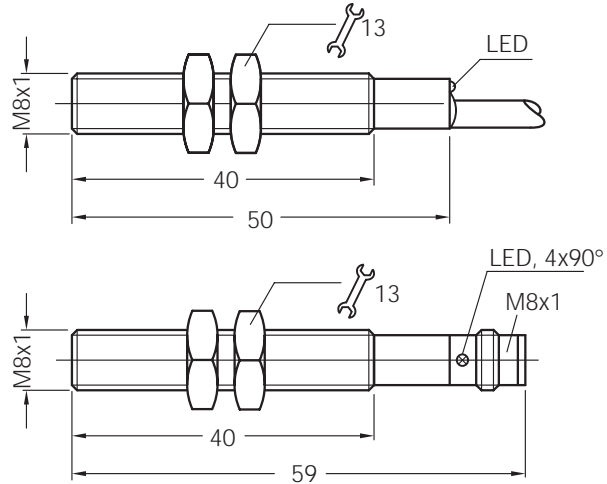

Features



- ▶ Can be installed flush and non-flush in metal
- ▶ Sensing range up to 60 mm
- ▶ PNP or NPN output
- ▶ High switching frequency
- ▶ Short-circuit protection (pulsed)
- ▶ Robust brass housing, nickel-plated with fine thread M8 x 1 mm
- ▶ Cable or connector
- ▶ Enclosure rating IP 67
- ▶ LED status indicator

Accessories

Round connectors
Magnets

Connection diagram

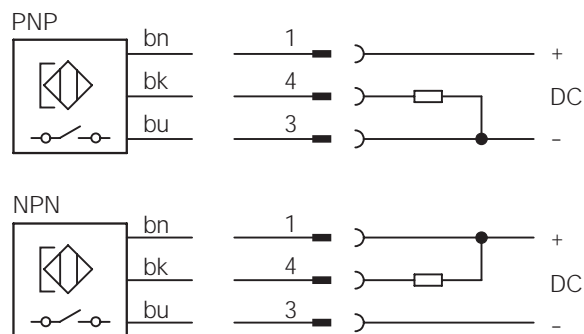

Wire colour	Wire colour	Contact	Assignment
bn	brown	1	+ V DC
bk	black	4	NO
bu	blue	3	- V DC

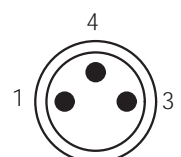

Electrical and mechanical data

Operating voltage U_b	10 ... 30 V DC	Wire-break protection	yes
Ripple U_{pp}	$\leq 10\%$ of U_b	Short-circuit protection (pulsed)	yes
Voltage drop U_d (at I_a max.)	≤ 1.5 V	Reverse polarity protection	yes
Power consumption (without load)	≤ 10 mA	Power-up pulse suppression	yes
Continuous current I_a	≤ 300 mA	Enclosure rating to EN 60529	IP 67
Time delay before availability t_v	≤ 2 ms	Shock and vibration stress	30 g, 11 ms 10 to 55 Hz, 1 mm
Hysteresis H	1% - 10% of s_r	Ambient temperature T_a	- 25 ... + 75 °C
Repeatability R (U_b and T_a constant)	$\leq 1\%$ of s_r	Housing material	Brass, nickel-plated, plastic
Temperature drift EMC	$\pm 10\%$ of s_r to EN 60 947-5-2	Tightening torque	0.8 Nm (with plastic nuts, included in package) 2.0 Nm (with metal nuts)
		Connection cable	PUR-PVC, 3 x 0.25 mm ²

Selection table

Sensing range s_n^* mm	Magnetic alignment	Switching output	Output function	Switching frequency f in Hz	Connection	Type	Order number
60	Axial	PNP		5000	Cable 2 m	MM08-60APS-ZU0	7900264
60	Axial	PNP		5000	Connector M8 x 1 mm	MM08-60APS-ZT0	7900266

* Sensing range s_n based on installation in non-magnetizable material using magnet M 4.0

Output NPN on request

Sensing ranges (Typical values)

Magnet type	Sensing range s_n Any installation type (flush or non-flush) in non-magnetizable material	Sensing range s_n Flush installation in magnetizable material (e.g. iron)
M 1.0	23 mm	12 mm
M 2.0	24 mm	10 mm
M 3.0	36 mm	15 mm
M 4.0	60 mm	20 mm
M 5.0 / 5.1	68 mm	25 mm

Magnetic proximity sensors

MM 12 series, sensing range 60 mm

DC 3-wire, metal housing

Dimensions in mm

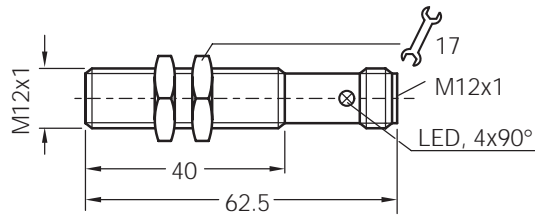
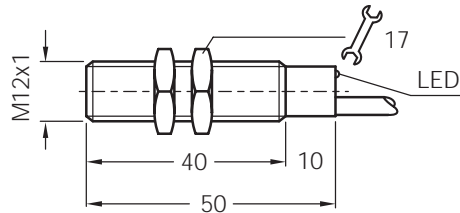

Features



- ▶ Can be installed flush and non-flush in metal
- ▶ Sensing range up to 60 mm
- ▶ PNP or NPN output
- ▶ High switching frequency
- ▶ Short-circuit protection (pulsed)
- ▶ Robust brass housing, nickel-plated with fine thread M12 x 1 mm
- ▶ Cable or connector
- ▶ Enclosure rating IP 67
- ▶ LED status indicator

Accessories

- Round connectors
- Magnets
- Mounting bracket

Connection diagram

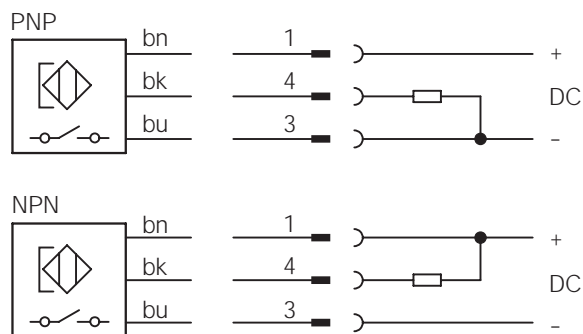

Wire colour	Colour	Contact	Assignment
bn	brown	1	+ V DC
bk	black	4	NO
bu	blue	3	- V DC
		2	free

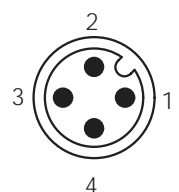

Electrical and mechanical data

Operating voltage U_b	10 ... 30 V DC	Wire-break protection	yes
Ripple U_{pp}	$\leq 10\%$ of U_b	Short-circuit protection (pulsed)	yes
Voltage drop U_d (at I_a max.)	≤ 1.5 V	Reverse polarity protection	yes
Power consumption (without load)	≤ 10 mA	Power-up pulse suppression	yes
Continuous current I_a	≤ 300 mA	Enclosure rating to EN 60529	IP 67
Time delay before availability t_v	≤ 2 ms	Shock and vibration stress	30 g, 11 ms 10 to 55 Hz, 1 mm
Hysteresis H	1% - 10% of s_r	Ambient temperature T_a	- 25 ... + 75 °C
Repeatability R (U_b and T_a constant)	$\leq 1\%$ of s_r	Housing material	Brass, nickel-plated, plastic
Temperature drift	$\pm 10\%$ of s_r	Tightening torque	7.0 Nm
EMC	to EN 60 947-5-2	Connection cable	PUR-PVC, 3 x 0.25 mm ²

Selection table

Sensing range s_n^* mm	Magnetic alignment	Switching output	Output function	Switching frequency f in Hz	Connection	Type	Order number
60	Axial	PNP		5000	Cable 2 m	MM12-60APS-ZU0	7900268
60	Axial	PNP		5000	Connector M12 x 1 mm	MM12-60APS-ZC0	7900270

* Sensing range s_n based on installation in non-magnetizable material using magnet M 4.0

Output NPN on request

Sensing ranges (Typical values)

Magnet type	Sensing range s_n Any installation version (flush or non-flush) in non-magnetizable material	Sensing range s_n Flush installation in magnetizable material (e.g. iron)
M 1.0	23 mm	17 mm
M 2.0	24 mm	14 mm
M 3.0	36 mm	23 mm
M 4.0	60 mm	37 mm
M 5.0 / 5.1	68 mm	44 mm

Magnetic proximity sensors

MM 18 sensors, sensing range 70 mm

DC 3-wire, metal housing

Dimensions in mm

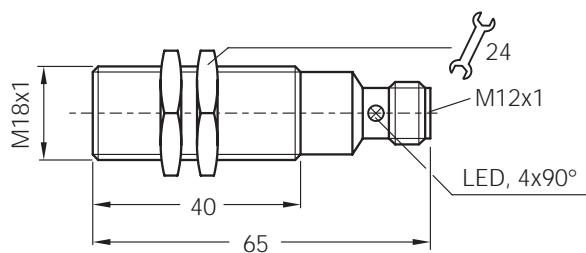
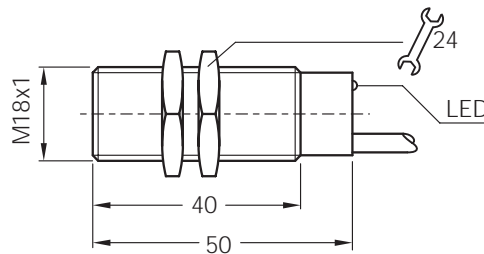

Features



- ▶ Can be installed flush and non-flush in metal
- ▶ Sensing range up to 70 mm
- ▶ PNP or NPN output
- ▶ High switching frequency
- ▶ Short-circuit protection (pulsed)
- ▶ Robust brass housing, nickel-plated with fine thread M18 x 1 mm
- ▶ Cable or connector
- ▶ Enclosure rating IP 67
- ▶ LED status indicator

Accessories

Round connectors
Magnets
Mounting bracket

Connection diagram

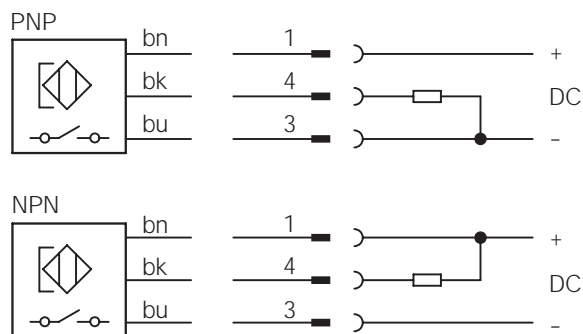

Wire colour	Colour	Contact	Assignment
bn	brown	1	+ V DC
bk	black	4	NO
bu	blue	3	- V DC
		2	free

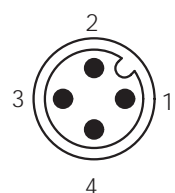

Electrical and mechanical data

Operating voltage U_b	10 ... 30 V DC	Wire-break protection	yes
Ripple U_{pp}	$\leq 10\%$ of U_b	Short-circuit protection (pulsed)	yes
Voltage drop U_d (at I_a max.)	≤ 1.5 V	Reverse polarity protection	yes
Current consumption (without load)	≤ 10 mA	Power-up pulse suppression	yes
Continuous current I_a	≤ 300 mA	Enclosure rating to EN 60529	IP 67
Time delay before availability t_v	≤ 2 ms	Shock and vibration stress	30 g, 11 ms 10 to 55 Hz, 1 mm
Hysteresis H	1% - 10% of s_r	Ambient temperature T_a	- 25 ... + 75 °C
Repeatability R (U_b and T_a constant)	$\leq 1\%$ of s_r	Housing material	Brass, nickel-plated, plastic
Temperature drift	$\pm 10\%$ of s_r	Tightening torque	25 Nm
EMC	to EN 60 947-5-2	Connection cable	PUR-PVC, 3 x 0.25 mm ²

Selection table

Sensing range s_n^* mm	Magnetic alignment	Switching output	Output function	Switching frequency f in Hz	Connection	Type	Order number
70	Axial	PNP		5000	Cable 2 m	MM18-70APS-ZU0	7900272
70	Axial	PNP		5000	Connector M12 x 1 mm	MM18-70APS-ZC0	7900274

* Sensing range s_n based on installation in non-magnetizable material using magnet M 4.0

Output NPN on request

Sensing ranges (Typical values)

Magnet type	Sensing range s_n Any installation version (flush or non-flush) in non-magnetizable material	Sensing range s_n Flush installation in magnetizable material (e.g. iron)
M 1.0	24 mm	20 mm
M 2.0	25 mm	17 mm
M 3.0	38 mm	32 mm
M 4.0	70 mm	55 mm
M 5.0 / 5.1	85 mm	60 mm

Magnetic proximity sensors

MQ 10 series, sensing range 60 mm

DC 3-wire, plastic housing

Dimensions in mm



Features



- ▶ Can be installed flush and non-flush in metal
- ▶ Sensing range up to 60 mm
- ▶ PNP or NPN output
- ▶ High switching frequency
- ▶ Short-circuit protection (pulsed)
- ▶ Plastic housing
- ▶ Cable or connector
- ▶ Enclosure rating IP 67
- ▶ LED status indicator

Accessories

Round connectors
Magnets

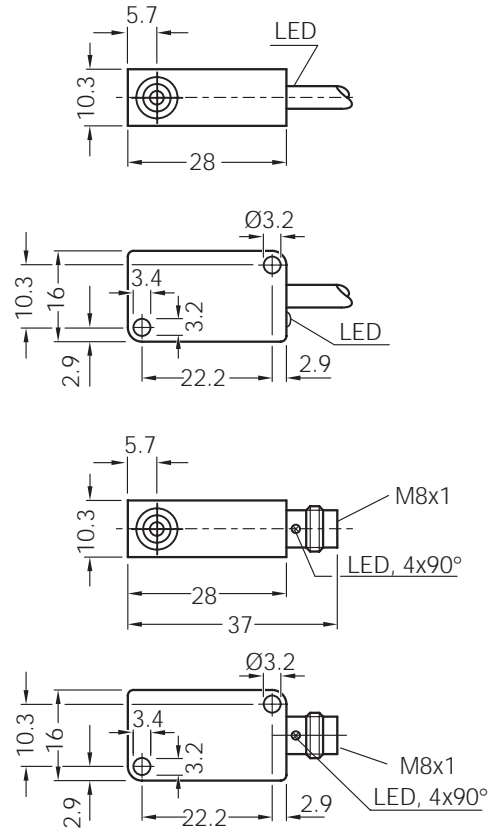

Connection diagram

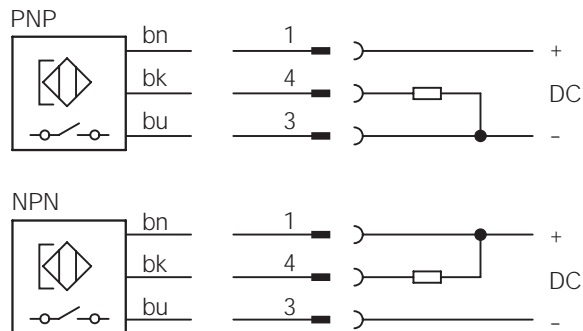

Wire colour	Wire colour	Contact	Assignment
bn	brown	1	+ V DC
bk	black	4	NO
bu	blue	3	- V DC

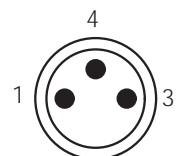

Electrical and mechanical data

Operating voltage U_b	10 ... 30 V DC	Wire-break protection	yes
Ripple U_{pp}	$\leq 10\%$ of U_b	Short-circuit protection (pulsed)	yes
Voltage drop U_d (at I_a max.)	≤ 1.5 V	Reverse polarity protection	yes
Power consumption (without load)	≤ 10 mA	Power-up pulse suppression	yes
Continuous current I_a	≤ 300 mA	Enclosure rating to EN 60529	IP 67
Time delay before availability t_v	≤ 2 ms	Shock and vibration stress	30 g, 11 ms 10 to 55 Hz, 1 mm
Hysteresis H	1% - 10% of s_r	Ambient temperature T_a	- 25 ... + 75 °C
Repeatability R (U_b and T_a constant)	$\leq 1\%$ of s_r	Housing material	Plastic
Temperature drift	$\pm 10\%$ of s_r	Connection cable	PUR-PVC, 3 x 0.25 mm ²
EMC	to EN 60 947-5-2		

Selection table

Sensing range s_n^* mm	Magnetic alignment	Switching output	Output function	Switching frequency f in Hz	Connection	Type	Order number
60	Axial	PNP		5000	Cable 2 m	MQ10-60APS-KU0	7900278
60	Axial	NPN		5000	Cable 2 m	MQ10-60ANS-KU0	7900279
60	Axial	PNP		5000	Connector M8 x 1 mm	MQ10-60APS-KT0	7900280
60	Axial	NPN		5000	Connector M8 x 1 mm	MQ10-60ANS-KT0	7900281

* Sensing range s_n based on installation in non-magnetizable material using magnet M 4.0

Sensing ranges (Typical values)

Magnet type	Sensing range s_n Any installation version (flush or non-flush) in non-magnetizable material	Sensing range s_n Flush installation in magnetizable material (e.g. iron)
M 1.0	23 mm	12 mm
M 2.0	24 mm	10 mm
M 3.0	36 mm	15 mm
M 4.0	60 mm	20 mm
M 5.0 / 5.1	68 mm	25 mm



Magnetic proximity sensors

MM 12 series, sensing range 60 mm

NAMUR, metal housing

Dimensions in mm

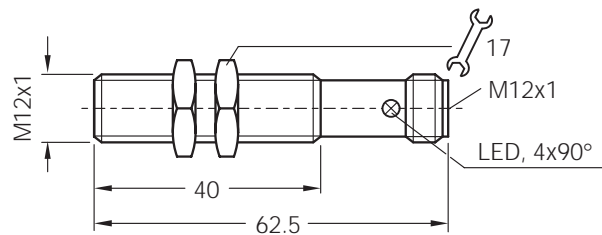
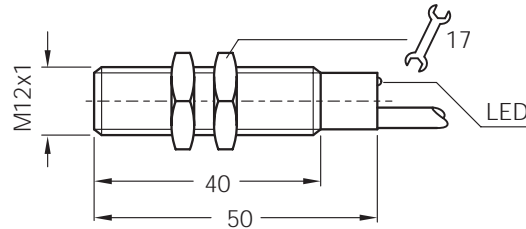

Features



- ▶ Can be installed flush and non-flush in metal
- ▶ Sensing ranges up to 60 mm
- ▶ NAMUR to EN 50 227
- ▶ High switching frequency
- ▶ Robust brass housing, nickel-plated, with fine thread M12 x 1 mm
- ▶ Cable or connector
- ▶ Enclosure rating IP 67
- ▶ LED status indicator
- ▶ **Classification**
TÜV 99 ATEX 1398
 EExibII CT6

Accessories

- Round connectors
- Magnets
- Mounting bracket
- Isolating unit EN 2 Ex

Connection diagram

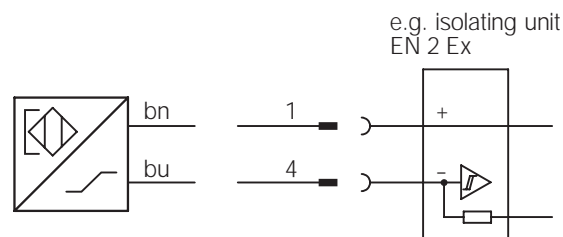

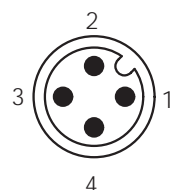

Wire colour	Contact	Assignment
bn brown	1	+ V DC
bu blue	4	- V DC
	3	free
	2	free



Electrical and mechanical data

Operating voltage U_b	5 ... 25 V DC	Short-circuit protected	yes
Rated voltage U_n	8.2 V DC	Reverse-polarity protected	yes
Ripple U_{pp}	$\leq 5\%$ of U_b	Enclosure rating to EN 60529	IP 67
Power consumption, attenuated	≥ 2.5 mA	Shock and vibration stress	30 g, 11 ms 10 to 55 Hz, 1 mm
Power consumption, unattenuated	≤ 1.0 mA	Ambient temperature T_a	- 25 ... + 70 °C
Internal capacitance	≤ 45 nF	Housing material	Brass, nickel-plated, plastic
Internal inductance	≤ 30 μ H	Tightening torque	7.0 Nm
Cable resistance	≤ 50 ω	Connection cable	PVC, 2 x 0.34 mm ² , blue
Time delay before availability t_v	≤ 2 ms		
Hysteresis H	1% - 10% of s_r		
Repeatability R (U_b and T_a constant)	$\leq 1\%$ of s_r		
Temperature drift	$\pm 10\%$ of s_r		
EMC	to EN 60 947-5-2		

Selection table

Sensing range s_n^* mm	Magnetic alignment	Version	Output function	Switching frequency f in Hz	Connection	Type	Order number
60	Axial	NAMUR		5000	Cable 2 m	MM12-60A-N-ZW0	7900286
60	Axial	NAMUR		5000	Connector M12 x 1 mm	MM12-60A-N-ZC0	7900287

* Sensing range s_n based on installation in non-magnetizable material using magnet M 4.0

Sensing ranges (Typical values)

Magnet type	Sensing range s_n Any installation version (flush or non-flush) in non-magnetizable material	Sensing range s_n Flush installation in magnetizable material (e.g. iron)
M 1.0	23 mm	17 mm
M 2.0	24 mm	14 mm
M 3.0	36 mm	23 mm
M 4.0	60 mm	37 mm
M 5.0 / 5.1	68 mm	44 mm

Magnetic proximity sensors

MM 18 series, sensing range 70 mm

NAMUR, metal housing

Dimensions in mm

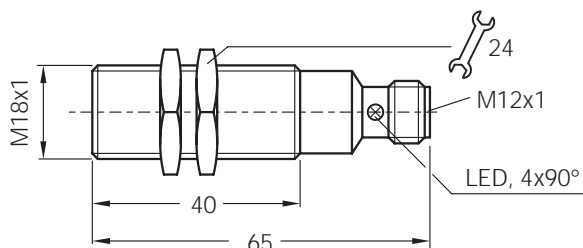
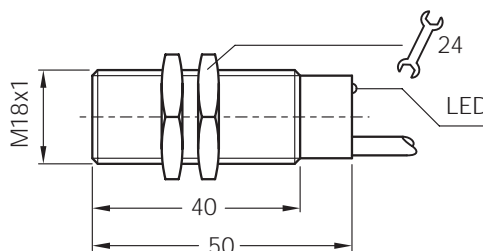

Features



- ▶ Can be installed flush and non-flush in metal
- ▶ Sensing ranges up to 70 mm
- ▶ NAMUR to EN 50 227
- ▶ High switching frequency
- ▶ Robust brass housing, nickel-plated, with fine thread M18 x 1 mm
- ▶ Cable or connector
- ▶ Enclosure rating IP 67
- ▶ LED status indicator
- ▶ **Classification**
TÜV 99 ATEX 1398
EExibII CT6

Accessories

- Round connectors
- Magnets
- Mounting bracket
- Isolating unit EN 2 Ex

Connection diagrams

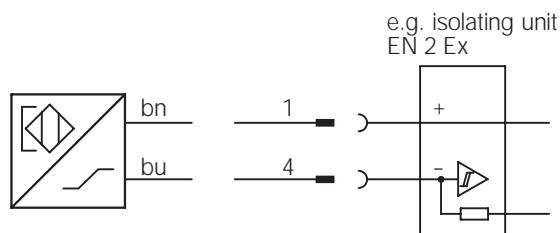

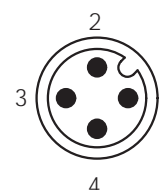

Wire colour	Contact	Assignment
bn brown	1	+ V DC
bu blue	4	- V DC
	3	free
	2	free



Electrical and mechanical data

Operating voltage U_b	5 ... 25 V DC	Short-circuit protected	yes
Rated voltage U_n	8.2 V DC	Reverse polarity protected	yes
Ripple U_{pp}	$\leq 5\%$ of U_b	Enclosure rating to EN 60529	IP 67
Power consumption, attenuated	≥ 2.5 mA	Shock and vibration stress	30 g, 11 ms 10 to 55 Hz, 1 mm
Power consumption, unattenuated	≤ 1.0 mA	Ambient temperature T_a	- 25 ... + 70 °C
Internal capacitance	≤ 45 nF	Housing material	Brass, nickel-plated, plastic
Internal inductance	≤ 30 μ H	Tightening torque	25 Nm
Cable resistance	≤ 50 ω	Connection cable	PVC, 2 x 0.34 mm ² , blue
Time delay before availability t_v	≤ 2 ms		
Hysteresis H	1% - 10% of s_r		
Repeatability R (U_b and T_a constant)	$\leq 1\%$ of s_r		
Temperature drift	$\pm 10\%$ of s_r		
EMC	to EN 60 947-5-2		

Selection table

Sensing range s_n^* mm	Magnetic alignment	Version	Output function	Switching frequency f in Hz	Connection	Type	Order number
70	Axial	NAMUR		5000	Cable 2 m	MM18-70A-N-ZW0	7900288
70	Axial	NAMUR		5000	Connector M12 x 1 mm	MM18-70A-N-ZC0	7900289

* Sensing range s_n based on installation in non-magnetizable material using magnet M 4.0

Sensing ranges (Typical values)

Magnet type	Sensing range s_n Any installation version (flush or non-flush) in non-magnetizable material	Sensing range s_n Flush installation in magnetizable material (e.g. iron)
M 1.0	24 mm	20 mm
M 2.0	25 mm	17 mm
M 3.0	38 mm	32 mm
M 4.0	70 mm	55 mm
M 5.0 / 5.1	85 mm	60 mm

Operating Principle

Magnetic cylinder sensors

Magnetic cylinder sensors are used to detect the position of pistons in pneumatic cylinders. They are attached directly to the cylinder body and operate according to the same principle as for magnetic proximity sensors.

They detect a ring magnet in the piston through the housing wall made of non-magnetizable material (aluminium, brass, stainless steel).

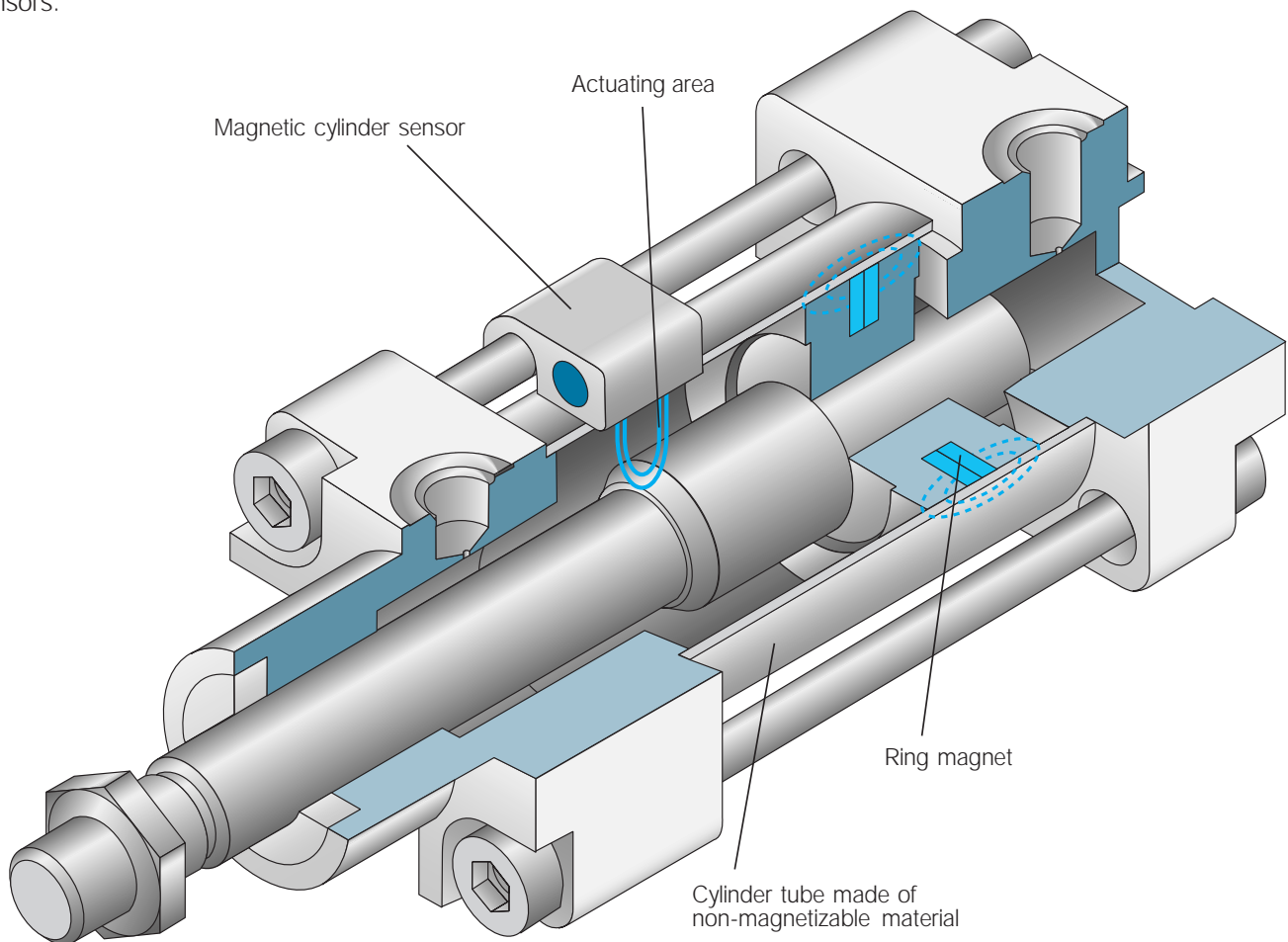

Response sensitivity

The magnetic induction of pneumatic cylinders is between 5 and 25 mTesla. A response sensitivity of 3 mTesla is enough to ensure signal triggering.

The sensitivity of 3 mT is a guide value which depends on the design of the cylinder.

Traverse distance s_u

The traverse distance s_u is between 5 and 20 mm, depending on the cylinder's construction (wall thickness, diameter, and magnetic induction). The typical hysteresis is 1 mm and remains constant.

Actuating speed

The short response times of the sensors allow actuating speeds of up to 5 m/s.

Product Overview

Magnetic cylinder sensors



MZ R1
Mounting on
round-body cylinders
Ø 8...63 mm using
mounting clamp
Page 136



MZ P3
Mounting on
integrated profile
cylinders with max.
rod diameter
of 14 mm
Page 144



MZ R2
Mounting on
round-body cylinders
Ø 8 ... 100 mm using
clamping band
Page 138



MZ P4
Mounting on
integrated profile
cylinders with max.
rod diameter
of 18 mm
Page 146



MZ Z1
Mounting on tie-
rod cylinders with
max. rod diameter
of 10 mm
Page 140



MZ K1, K3
Mounting on
cylinders with
dovetail slot
Page 148



MZ Z2
Mounting on tie-
rod cylinders with
max. rod diameter
of 12.5 mm
Page 142



MZ F1
Mounting in T-slot
Page 152

Product Overview

Magnetic cylinder sensors



MZT 1
Mounting in T-slot.
Mountable from the top.
Page 154

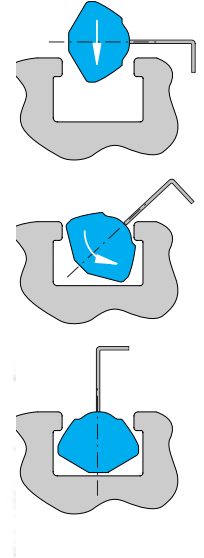
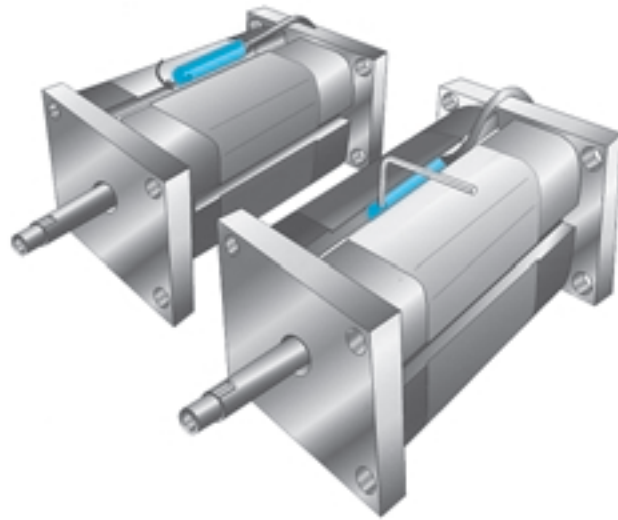

MZU 2 – weld immune Version
Mounting on different cylinder types
Page 158



Magnet actuated indicator systems like the magnetic cylinder sensors for pneumatic cylinders can be disturbed by strong magnetic fields. In weld environments this kind of magnetic field can occur. The magnetic cylinder sensors of series MZU2 are equipped with an interference field sensor to detect these interference fields caused by AC-, DC- or medium frequency welders. The response sensitivity of the interference detector is $> 2 \text{ mT}$ and locks the output during the welding process at the last known state. When the welding process stops, the sensor updates the output accordingly.

Type Code

Magnetic cylinder sensors

Character	1	2	3	4	5	6	7	8	9	11	12	13	14	Character
	M	Z	R	1	-	O	3	V	P	-	A	U	O	
1 Sensor technology	M Magnetic													other codes
	R Reed switch													M Weld immune
2 Design		Z Cylinder sensor												Connection
														W Cable, PVC
														U Cable, PUR-PVC
														P Cable with connector, M8x1
														T Connector, M8x1
														C Connector, M12x1
3/4 Application														housing material
	R1 Round-body cylinder													A Aluminium
	R2 Round-body cylinder													K Plastic
	Z1 Tie-rod cylinder													D Die-cast zinc
	Z2 Tie-rod cylinder													T Die-cast zinc with teflon coating
	P3 Integrated Profile cylinder													
	P4 Integrated Profile cylinder													
	K1 Short-stroke cylinder													
	K3 Short-stroke cylinder													
	F1 T-slot													
	U2 Universal													
	T1 T-Nut													
6/7/8 Response sensitivity, sensor position														Output
	02 in mT													S NO
	03 in mT													N NAMUR
	V Sensor, front													
	Z Sensor, centre													
														Interface
														P DC (3-wire) PNP
														N DC (3-wire) NPN
														U AC/DC 2-wire
														R Reed (3-wire)
														- NAMUR



Magnetic cylinder sensors

MZ R1 series

DC 3-wire, for round-body cylinders

Dimensions in mm

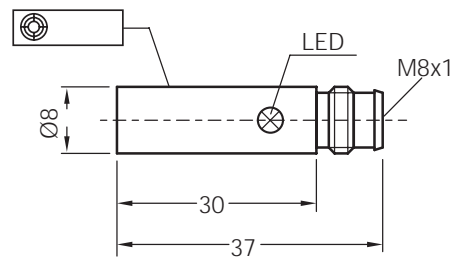
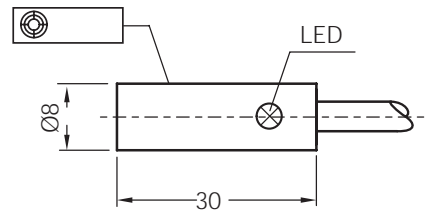

Features



- ▶ Non-contact determination of piston position in pneumatic cylinders
- ▶ Mounting on round-body cylinders Ø 8 ... 63 mm using R1 mounting clamp
- ▶ High response sensitivity ≥ 3 mT
- ▶ Frontal sensing face
- ▶ No secondary switching ranges
- ▶ High repeat accuracy
- ▶ Actuating speed ≤ 5 m/s
- ▶ PNP or NPN output
- ▶ Short-circuit protection (pulsed)
- ▶ Solid aluminium housing
- ▶ Cable or connector
- ▶ Enclosure rating IP 67
- ▶ LED status indicator

Accessories

Round connectors

Connection diagram

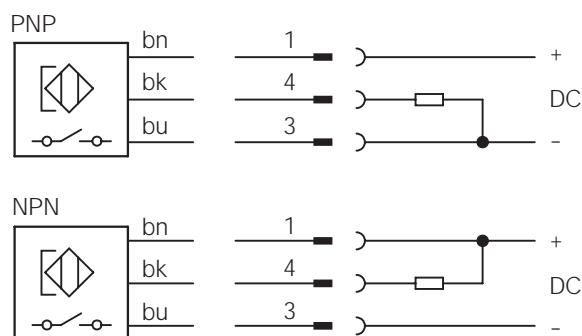



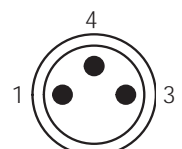





Wire colour	Contact	Assignment
bn brown	1	+ V DC
bk black	4	NO
bu blue	3	- V DC



Electrical and mechanical data

Operating voltage U_b	10 ... 30 V DC	Wire-break protection	yes
Ripple U_{pp}	$\leq 10\%$ of U_b	Short-circuit protection (pulsed)	yes
Voltage drop U_d (at I_a max.)	≤ 1.5 V	Reverse polarity protection	yes
Power consumption (without load)	≤ 10 mA	Power-up pulse suppression	yes
Continuous current I_a	≤ 300 mA	Enclosure rating to EN 60529	IP 67
Time delay before availability t_v	≤ 2 ms	Shock and vibration stress	30 g, 11 ms 10 to 55 Hz, 1 mm
Hysteresis H	≤ 1.0 mm	Ambient temperature T_a	- 25 ... + 75 °C
Repeatability R (U_b and T_a constant)	≤ 0.1 mm	Housing material	Aluminium, plastic
EMC	to EN 60 947-5-2	Connection cable	PUR-PVC, 3 x 0.25 mm ²

Selection table

Response sensitivity in mT	Sensing face	Switching output	Output function	Switching frequency f in Hz	Connection	Type	Order number
3		PNP		5000	Cable 2 m	MZR1-03VPS-AU0	7900592
3		NPN		5000	Cable 2 m	MZR1-03VNS-AU0	7900593
3		PNP		5000	Connector M8 x 1 mm	MZR1-03VPS-AT0	7900594
3		NPN		5000	Connector M8 x 1 mm	MZR1-03VNS-AT0	7900595

Series is available as reed switch on request.

Accessories

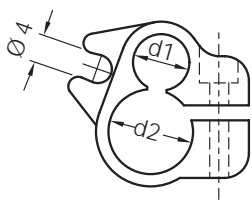

Mounting clamp

Plastic
for magnetic cylinder sensor R1
with d_1 \varnothing 8 mm

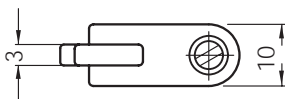

For cylinders with piston diameter

8 mm
10 mm
12 mm
16 mm
20 mm
25 mm
32 mm
40 mm
50 mm
63 mm

Clamping range d2 in mm

9,2 ... 10,0
10,9 ... 12,0
12,9 ... 14,0
16,9 ... 18,0
21,0 ... 22,0
26,1 ... 27,2
33,0 ... 35,0
41,4 ... 42,5
52,5 ... 54,0
66,0 ... 67,0

Type

BEF-S-R1-08
BEF-S-R1-10
BEF-S-R1-12
BEF-S-R1-16
BEF-S-R1-20
BEF-S-R1-25
BEF-S-R1-32
BEF-S-R1-40
BEF-S-R1-50
BEF-S-R1-63

Order-Nr.

7902337
7901753
7901754
7901755
7901756
7901757
7901758
7901759
7901760
7901761



Magnetic cylinder sensors

MZ R2 series

DC 3-wire, for round-body cylinders

Dimensions in mm

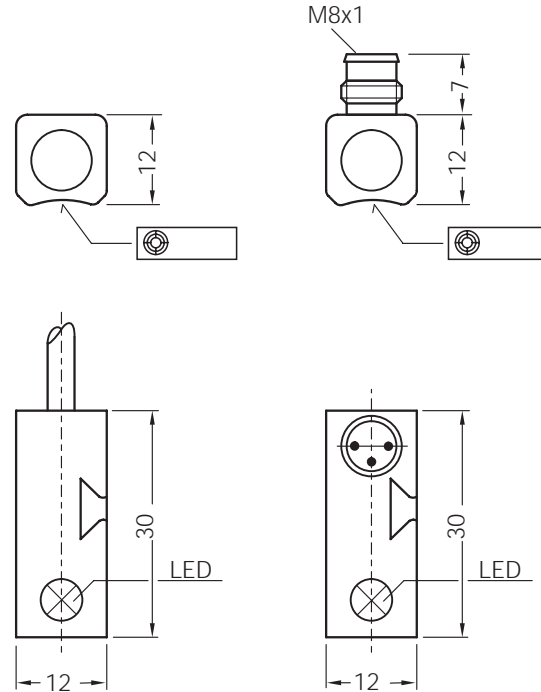

Features



- ▶ Non-contact determination of piston position in pneumatic cylinders
- ▶ Universal mounting using clamping band for max. cylinder diameter of 100 mm
- ▶ High response sensitivity $\geq 3 \text{ mT}$
- ▶ Frontal sensing face
- ▶ No secondary switching ranges
- ▶ High repeat accuracy
- ▶ Actuating speed $\leq 5 \text{ m/s}$
- ▶ PNP or NPN output
- ▶ Short-circuit protection (pulsed)
- ▶ Solid aluminium housing
- ▶ Cable or connector
- ▶ Enclosure rating IP 67
- ▶ LED status indicator

Accessories

Round connectors

Connection diagram

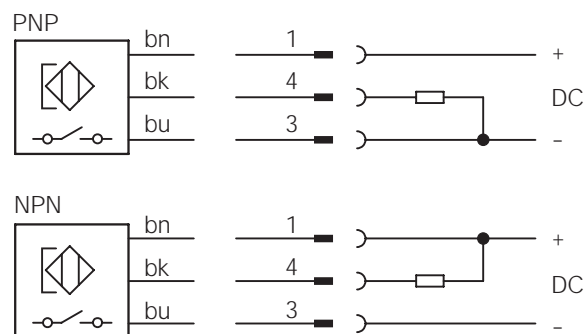



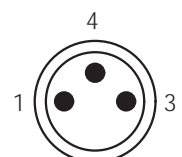





Wire colour	Contact	Assignment
bn	brown	1 + V DC
bk	black	4 NO
bu	blue	3 - V DC



Electrical and mechanical data

Operating voltage U_b	10 ... 30 V DC	Wire-break protection	yes
Ripple U_{pp}	$\leq 10\%$ of U_b	Short-circuit protection (pulsed)	yes
Voltage drop U_d (at I_a max.)	≤ 1.5 V	Reverse polarity protection	yes
Power consumption (without load)	≤ 10 mA	Power-up pulse suppression	yes
Continuous current I_a	≤ 300 mA	Enclosure rating to EN 60529	IP 67
Time delay before availability t_v	≤ 2 ms	Shock and vibration stress	30 g, 11 ms 10 to 55 Hz, 1 mm
Hysteresis H	≤ 1.0 mm	Ambient temperature T_a	- 25 ... + 75 °C
Repeatability R (U_b and T_a constant)	≤ 0.1 mm	Housing material	Aluminium, plastic
EMC	to EN 60 947-5-2	Connection cable	PUR-PVC, 3 x 0.25 mm ²

Selection table

Response sensitivity in mT	Sensing face	Switching output	Output function	Switching frequency f in Hz	Connection	Type	Order number
3		PNP		5000	Cable 2 m	MZR2-03VPS-AU0	7900598
3		NPN		5000	Cable 2 m	MZR2-03VNS-AU0	7900599
3		PNP		5000	Connector M8 x 1 mm	MZR2-03VPS-AT0	7900600
3		NPN		5000	Connector M8 x 1 mm	MZR2-03VNS-AT0	7900601

Accessories

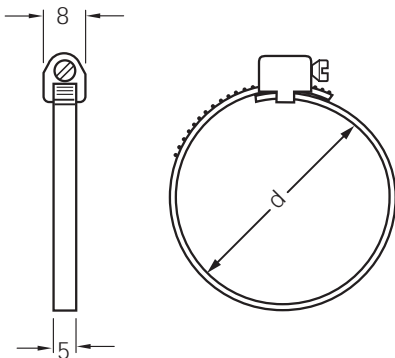

Clamping band

stainless steel
for magnetic cylinder sensor R2

For cylinder range with piston diameter	Clamping range d in mm	Type	Order-No.
8 ... 16 mm	18 - 29	BEF-S-R2-16	7901762
20/25 mm	28 - 39	BEF-S-R2-25	7901763
32 mm	38 - 49	BEF-S-R2-30	7901764
40 mm	48 - 59	BEF-S-R2-40	7901765
50 mm	58 - 69	BEF-S-R2-50	7901766
63 mm	68 - 79	BEF-S-R2-63	7901767
80 mm	88 - 99	BEF-S-R2-80	7901768
100 mm	98 - 109	BEF-S-R2-100	7901769

Magnetic cylinder sensors

MZ Z1 series

DC 3-wire, for tie-rod cylinders

Dimensions in mm

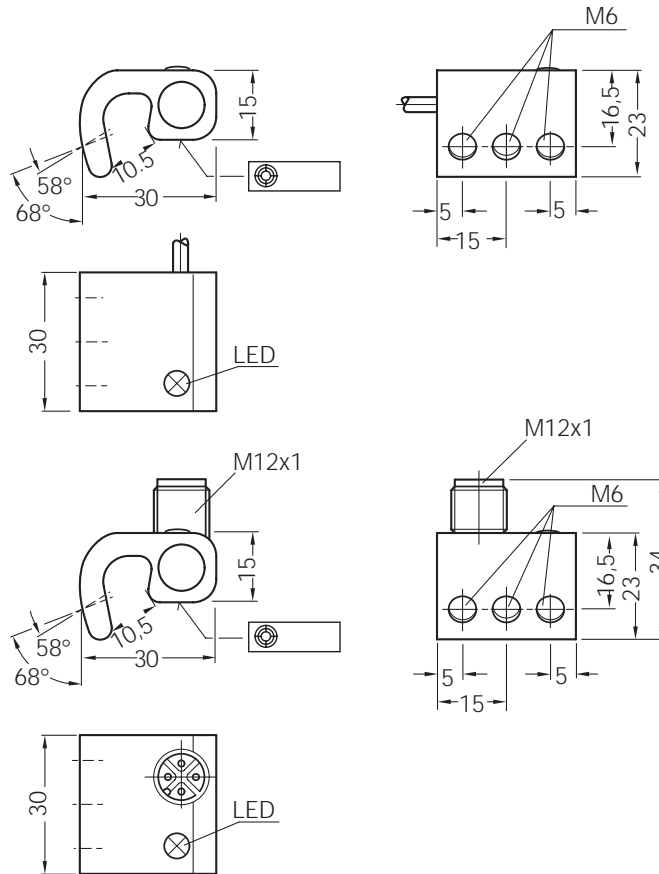

Features



- ▶ Non-contact determination of piston position in pneumatic cylinders
- ▶ Tie-rod mounting for max. rod diameter of 10 mm
- ▶ High response sensitivity ≥ 3 mT
- ▶ Frontal sensing face
- ▶ No secondary switching ranges
- ▶ High repeat accuracy
- ▶ Actuating speed ≤ 5 m/s
- ▶ PNP or NPN output
- ▶ Short-circuit protection (pulsed)
- ▶ Solid aluminium housing with integrated mounting claw
- ▶ Cable or connector
- ▶ Enclosure rating IP 67
- ▶ LED status indicator

Accessories

Round connectors

Connection diagram

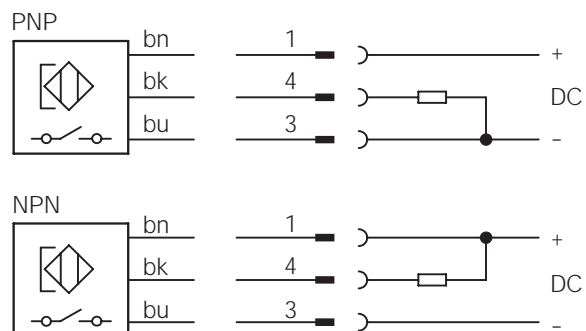



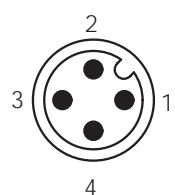



Wire colour	Contact	Assignment
bn brown	1	+ V DC
bk black	4	NO
bu blue	3	- V DC
	2	free



Electrical and mechanical data

Operating voltage U_b	10 ... 30 V DC	Wire-break protection	yes
Ripple U_{pp}	$\leq 10\%$ of U_b	Short-circuit protection (pulsed)	yes
Voltage drop U_d (at I_a max.)	≤ 1.5 V	Reverse polarity protection	yes
Power consumption (without load)	≤ 10 mA	Power-up pulse suppression	yes
Continuous current I_a	≤ 300 mA	Enclosure rating to EN 60529	IP 67
Time delay before availability t_v	≤ 2 ms	Shock and vibration stress	30 g, 11 ms 10 to 55 Hz, 1 mm
Hysteresis H	≤ 1.0 mm	Ambient temperature T_a	- 25 ... + 75 °C
Repeatability R (U_b and T_a constant)	≤ 0.1 mm	Housing material	Aluminium, plastic
EMC	of EN 60 947-5-2	Connection cable	PUR-PVC, 3 x 0.25 mm ²

Selection table

Response sensitivity in mT	Sensing face	Switching output	Output function	Switching frequency f in Hz	Connection	Type	Order number
3		PNP		5000	Cable 2 m	MZZ1-03VPS-AU0	7900606
3		PNP		5000	Connector M12 x 1 mm	MZZ1-03VPS-AC0	7900608
3		NPN		5000	Connector M12 x 1 mm	MZZ1-03VNS-AC0	7900609

Magnetic cylinder sensors

MZ Z2 series

DC 3-wire, for tie-rod cylinders

Dimensions in mm

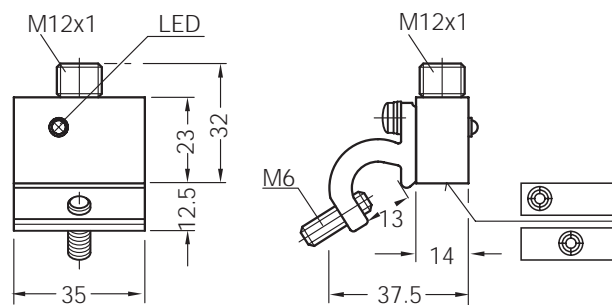
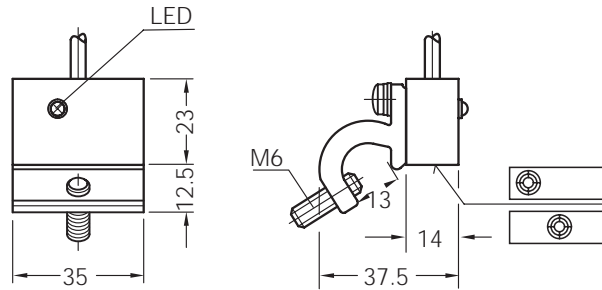

Features



- ▶ Non-contact determination of piston position in pneumatic cylinders
- ▶ Mounting on tie-rods with max. rod diameter of 12.5 mm
- ▶ High response sensitivity ≥ 3 mT
- ▶ Frontal or central sensing face
- ▶ No secondary switching ranges
- ▶ High repeat accuracy
- ▶ Actuating speed ≤ 5 m/s
- ▶ PNP or NPN output
- ▶ Short-circuit protection (pulsed)
- ▶ Solid aluminium construction with integrated mounting and plastic housing
- ▶ Cable or connector
- ▶ Enclosure rating IP 67
- ▶ LED status indicator

Accessories

Round connectors

Connection diagram

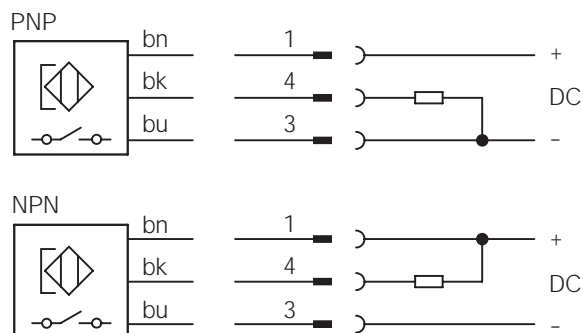



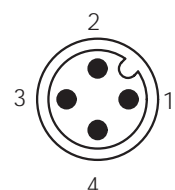







Wire colour	Contact	Assignment
bn	brown	1 + V DC
bk	black	4 NO
bu	blue	3 - V DC
	2	free



Electrical and mechanical data

Operating voltage U_b	10 ... 30 V DC	Wire-break protection	yes
Ripple U_{pp}	$\leq 10\%$ of U_b	Short-circuit protection (pulsed)	yes
Voltage drop U_d (at I_a max.)	≤ 1.5 V	Reverse polarity protection	yes
Power consumption (without load)	≤ 10 mA	Power-up pulse suppression	yes
Continuous current I_a	≤ 300 mA	Enclosure rating to EN 60529	IP 67
Time delay before availability t_v	≤ 2 ms	Shock and vibration stress	30 g, 11 ms 10 to 55 Hz, 1 mm
Hysteresis H	≤ 1.0 mm	Ambient temperature T_a	- 25 ... + 75 °C
Repeatability R (U_b and T_a constant)	≤ 0.1 mm	Housing material	Aluminium, plastic
EMC	to EN 60 947-5-2	Connection cable	PUR-PVC, 3 x 0.25 mm ²

Selection table

Response sensitivity in mT	Sensing face	Switching output	Output function	Switching frequency f in Hz	Connection	Type	Order number
3		PNP		5000	Cable 2 m	MZZ2-03ZPS-KU0	7900618
3		NPN		5000	Cable 2 m	MZZ2-03ZNS-KU0	7900619
3		PNP		5000	Connector M12 x 1 mm	MZZ2-03ZPS-KC0	7900620
3		PNP		5000	Cable 2 m	MZZ2-03VPS-KU0	7900622
3		PNP		5000	Connector M12 x 1 mm	MZZ2-03VPS-KC0	7900624

Magnetic cylinder sensors

MZ P3 series

DC 3-wire, for integrated profile cylinders

Dimensions in mm

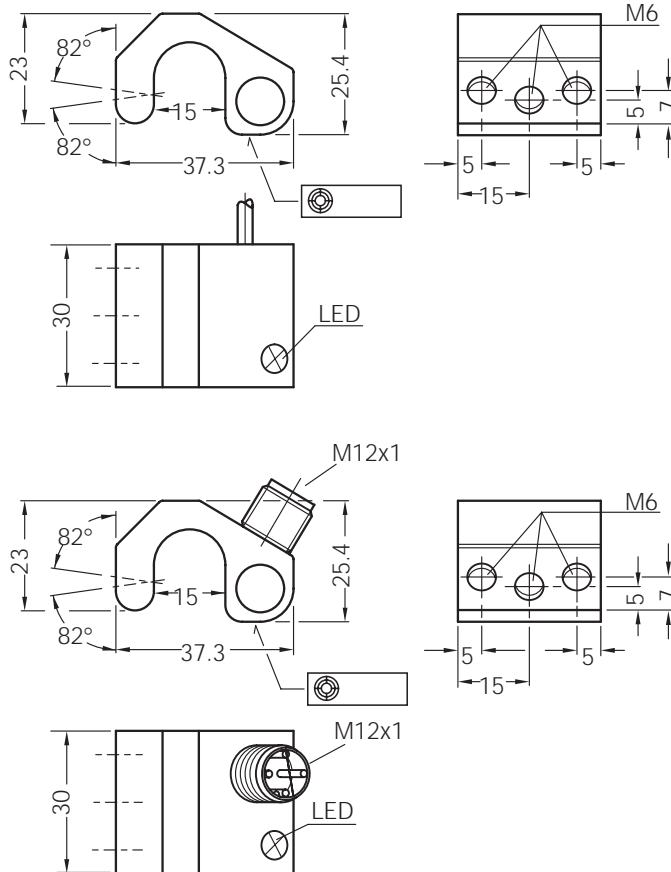
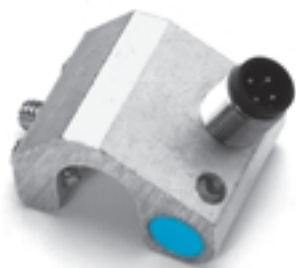

Features



- ▶ Non-contact determination of piston position in pneumatic cylinders
- ▶ Mounting on integrated profile with max. width of 14 mm
- ▶ High response sensitivity ≥ 3 mT
- ▶ Frontal sensing face
- ▶ No secondary switching ranges
- ▶ High repeat accuracy
- ▶ Actuating speed ≤ 5 m/s
- ▶ PNP output
- ▶ Short-circuit protection (pulsed)
- ▶ Solid aluminium housing with integrated mounting claw
- ▶ Cable or connector
- ▶ Enclosure rating IP 67
- ▶ LED status indicator

Accessories

Round connectors

Connection diagram

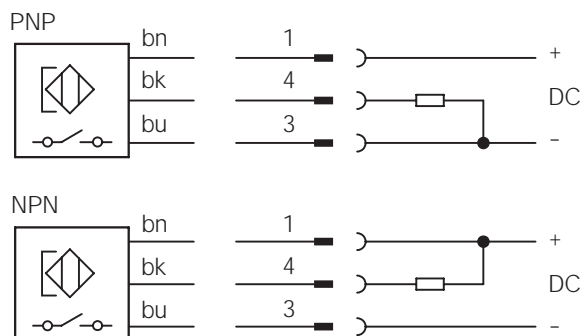



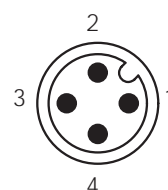

Wire colour	Contact	Assignment
bn brown	1	+ V DC
bk black	4	NO
bu blue	3	- V DC
	2	free



Electrical and mechanical data

Operating voltage U_b	10 ... 30 V DC	Wire-break protection	yes
Ripple U_{pp}	$\leq 10\%$ of U_b	Short-circuit protection (pulsed)	yes
Voltage drop U_d (at I_a max.)	≤ 1.5 V	Reverse polarity protection	yes
Power consumption (without load)	10 mA	Power-up pulse suppression	yes
Continuous current I_a	≤ 300 mA	Enclosure rating to EN 60529	IP 67
Time delay before availability t_v	≤ 2 ms	Shock and vibration stress	30 g, 11 ms 10 to 55 Hz, 1 mm
Hysteresis H	≤ 1.0 mm	Ambient temperature T_a	- 25 ... + 75 °C
Repeatability R (U_b and T_a constant)	≤ 0.1 mm	Housing material	Aluminium, plastic
EMC	to EN 60 947-5-2	Connection cable	PUR-PVC, 3 x 0.25 mm ²

Selection table

Response sensitivity in mT	Sensing face	Switching output	Output function	Switching frequency f in Hz	Connection	Type	Order number
3		PNP		5000	Cable 2 m	MZP3-03VPS-AU0	7900610
3		PNP		5000	Connector M12 x 1 mm	MZP3-03VPS-AC0	7900612

Magnetic cylinder sensors

MZ P4 series

DC 3-wire, for integrated profile cylinders

Dimensions in mm

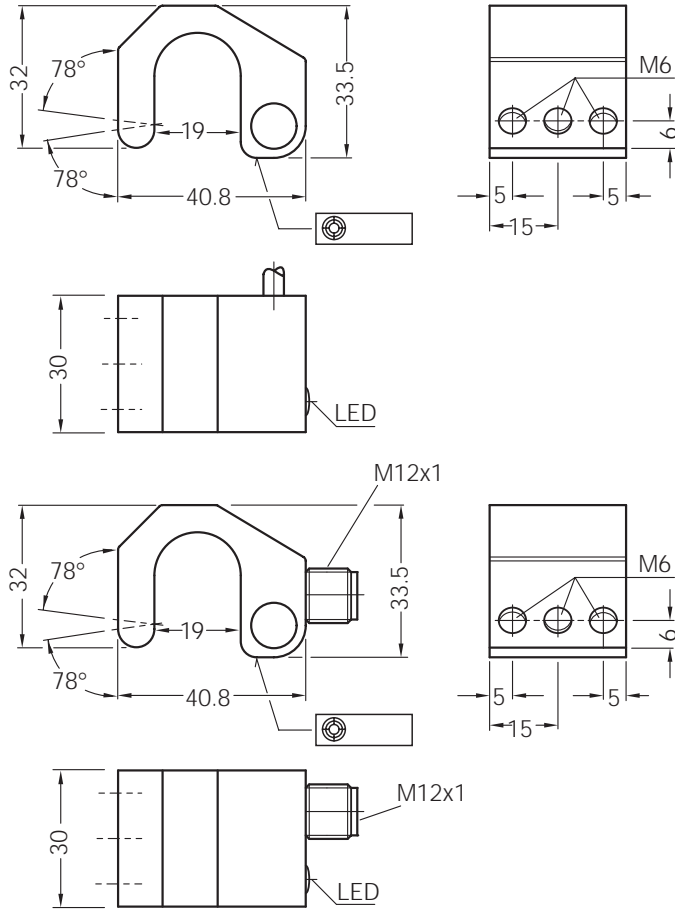

Features



- ▶ Non-contact determination of piston position in pneumatic cylinders
- ▶ Mounting on integrated profile with max. width of 18 mm
- ▶ High response sensitivity ≥ 3 mT
- ▶ Frontal sensing face
- ▶ No secondary switching ranges
- ▶ High repeat accuracy
- ▶ Actuating speed ≤ 5 m/s
- ▶ PNP output
- ▶ Short-circuit protection (pulsed)
- ▶ Solid aluminium housing with integrated mounting claw
- ▶ Cable or connector
- ▶ Enclosure rating IP 67
- ▶ LED status indicator

Accessories

Round connectors

Connection diagram

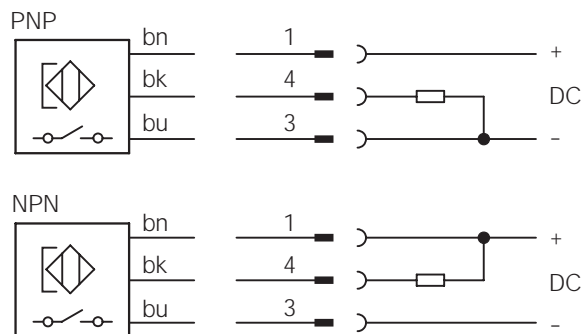



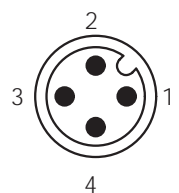

Wire colour	Contact	Assignment
bn	brown	1 + V DC
bk	black	4 NO
bu	blue	3 - V DC
	2	free



Electrical and mechanical data

Operating voltage U_b	10 ... 30 V DC	Wire-break protection	yes
Ripple U_{pp}	$\leq 10\%$ of U_b	Short-circuit protection (pulsed)	yes
Voltage drop U_d (at I_a max.)	≤ 1.5 V	Reverse polarity protection	yes
Power consumption (without load)	≤ 10 mA	Power-up pulse suppression	yes
Continuous current I_a	≤ 300 mA	Enclosure rating to EN 60529	IP 67
Time delay before availability t_v	≤ 2 ms	Shock and vibration stress	30 g, 11 ms 10 to 55 Hz, 1 mm
Hysteresis H	≤ 1.0 mm	Ambient temperature T_a	- 25 ... + 75 °C
Repeatability R (U_b and T_a constant)	≤ 0.1 mm	Housing material	Aluminium, plastic
EMC	to EN 60 947-5-2	Connection cable	PUR-PVC, 3 x 0.25 mm ²

Selection table

Response sensitivity in mT	Sensing face	Switching output	Output function	Switching frequency f in Hz	Connection	Type	Order number
3		PNP		5000	Cable 2 m	MZP4-03VPS-AU0	7900614
3		PNP		5000	Connector M12 x 1 mm	MZP4-03VPS-AC0	7900616

Magnetic cylinder sensors

MZ K1 series

DC 3-wire, for short-stroke cylinders

Dimensions in mm

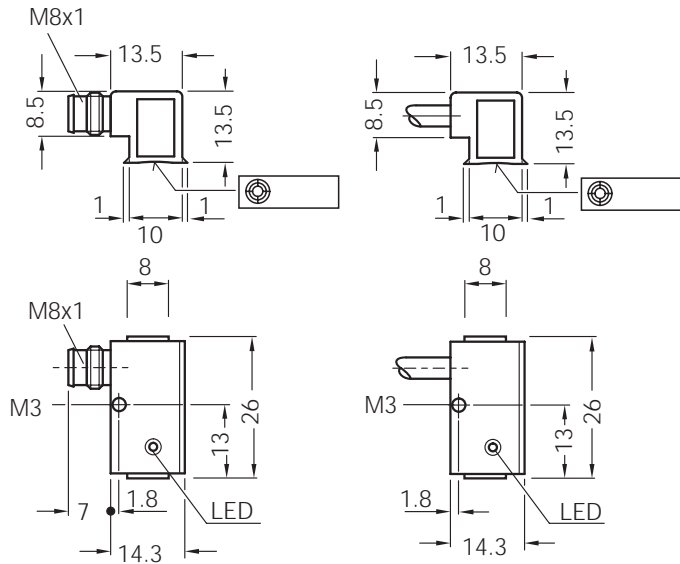

Features



- ▶ Non-contact determination of piston position in pneumatic cylinders
- ▶ Simple mounting on short-stroke cylinders
- ▶ High response sensitivity ≥ 2 mT
- ▶ Frontal sensing face
- ▶ No secondary switching ranges
- ▶ High repeat accuracy
- ▶ Actuating speed ≤ 5 m/s
- ▶ PNP output
- ▶ Short-circuit protection (pulsed)
- ▶ Solid aluminium housing with special profile and clamping screw
- ▶ Cable or connector
- ▶ Enclosure rating IP 67
- ▶ LED status indicator

Accessories

Round connectors

Connection diagram

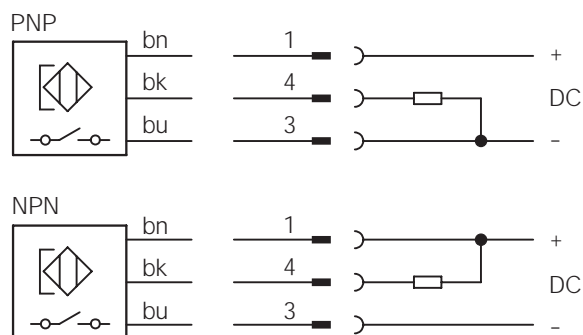



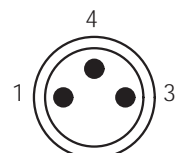

Wire colour	Contact	Assignment
bn	brown	1 + V DC
bk	black	4 NO
bu	blue	3 - V DC



Electrical and mechanical data

Operating voltage U_b	10 ... 30 V DC	Wire-break protection	yes
Ripple U_{pp}	$\leq 10\%$ of U_b	Short-circuit protection (pulsed)	yes
Voltage drop U_d (at I_a max.)	≤ 1.5 V	Reverse polarity protection	yes
Power consumption (without load)	≤ 10 mA	Power-up pulse suppression	yes
Continuous current I_a	≤ 300 mA	Enclosure rating to EN 60529	IP 67
Time delay before availability t_v	≤ 2 ms	Shock and vibration stress	30 g, 11 ms 10 to 55 Hz, 1 mm
Hysteresis H	≤ 1.0 mm	Ambient temperature T_a	- 25 ... + 75 °C
Repeatability R (U_b and T_a constant)	≤ 0.1 mm	Housing material	Aluminium, plastic
EMC	to EN 60 947-5-2	Connection cable	PUR-PVC, 3 x 0.25 mm ²

Selection table

Response sensitivity in mT	Sensing face	Switching output	Output function	Switching frequency f in Hz	Connection	Type	Order number
2		PNP		5000	Cable 2 m	MZK1-02VPS-AU0	7900602
2		PNP		5000	Connector M8 x 1 mm	MZK1-02VPS-AT0	7900604

Magnetic cylinder sensors

MZ K3 series

DC 3-wire, for short-stroke cylinders

Dimensions in mm

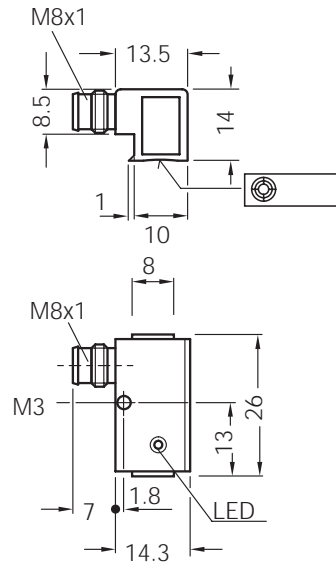

Features



- ▶ Non-contact determination of piston position in pneumatic cylinders
- ▶ **Mountable from the top**
- ▶ Simple mounting on short-stroke cylinders
- ▶ High response sensitivity $\geq 2 \text{ mT}$
- ▶ Frontal sensing face
- ▶ No secondary switching ranges
- ▶ High repeat accuracy
- ▶ Actuating speed $\leq 5 \text{ m/s}$
- ▶ PNP or NPN output
- ▶ Short-circuit protection (pulsed)
- ▶ Solid aluminium housing with special profile and clamping screw
- ▶ Cable
- ▶ Enclosure rating IP 67
- ▶ LED status indicator

Accessories

Round connectors

Connection diagram

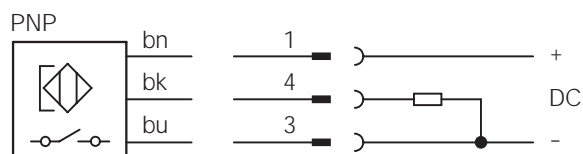

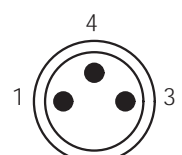

Wire colour	Wire colour	Contact	Assignment
bn	brown	1	+ V DC
bk	black	4	NO
bu	blue	3	- V DC



Electrical and mechanical data

Operating voltage U_b	10 ... 30 V DC	Wire-break protection	yes
Ripple U_{pp}	$\leq 10\%$ of U_b	Short-circuit protection (pulsed)	yes
Voltage drop U_d (at I_a max.)	≤ 1.5 V	Reverse polarity protection	yes
Power consumption (without load)	≤ 10 mA	Power-up pulse suppression	yes
Continuous current I_a	≤ 300 mA	Enclosure rating to EN 60529	IP 67
Time delay before availability t_v	≤ 2 ms	Shock and vibration stress	30 g, 11 ms 10 to 55 Hz, 1 mm
Hysteresis H	≤ 1.0 mm	Ambient temperature T_a	- 25 ... + 75 °C
Repeatability R (U_b and T_a constant)	≤ 0.1 mm	Housing material	Aluminium, plastic
EMC	to EN 60 947-5-2	Connection cable	PUR-PVC, 3 x 0.25 mm ²

Selection table

Response sensitivity in mT	Sensing face	Switching output	Output function	Switching frequency f in Hz	Connection	Type	Order number
2		PNP		5000	Connector M8 x 1 mm	MZK3-02VPS-AT0	7901952



Magnetic cylinder sensors

MZ F1 series

DC 3-wire, for T-slot

Dimensions in mm

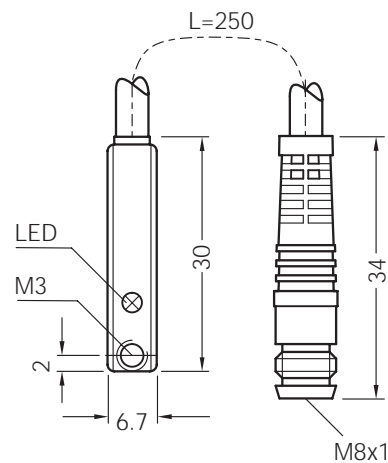
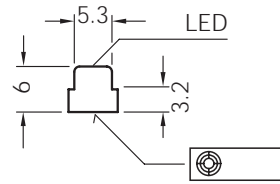

Features



- ▶ Non-contact determination of piston position in pneumatic cylinders
- ▶ For T-slot
- ▶ High response sensitivity ≥ 3 mT
- ▶ Frontal sensing face
- ▶ No secondary switching ranges
- ▶ High repeat accuracy
- ▶ Actuating speed ≤ 5 m/s
- ▶ PNP output
- ▶ Short-circuit protection (pulsed)
- ▶ Plastic housing with T-profile and clamping screw
- ▶ Connection cable or connector on cable
- ▶ Enclosure rating IP 67
- ▶ LED status indicator
- ▶ Magneto-resistive element

Accessories

Round connectors

Connection diagram

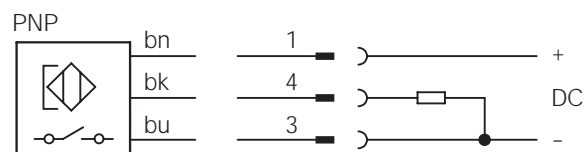



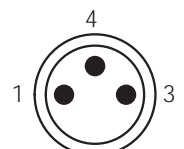



Wire colour	Wire colour	Contact	Assignment
bn	brown	1	+ V DC
bk	black	4	NO
bu	blue	3	- V DC



Electrical and mechanical data

Operating voltage U_b	10 ... 30 V DC	Wire-break protection	yes
Ripple U_{pp}	$\leq 10\%$ of U_b	Short-circuit protection (pulsed)	yes
Voltage drop U_d (at I_a max.)	≤ 2 V	Reverse polarity protection	yes
Power consumption (without load)	≤ 10 mA	Power-up pulse suppression	yes
Continuous current I_a	≤ 150 mA	Enclosure rating to DIN 40050	IP 67
Time delay before availability t_v	≤ 2 ms	Shock and vibration stress	30 g, 11 ms 10 to 55 Hz, 1 mm
Hysteresis H	≤ 1.5 mm	Ambient temperature T_a	- 25 ... + 75 °C
Repeatability R (U_b and T_a constant)	≤ 0.2 mm	Housing material	Plastic
EMC	to EN 60 947-5-2	Connection cable	PUR-PVC, 3 x 0.25 mm ²
		Connection cable w. M8x1 mm	PUR

Selection table

Response sensitivity in mT	Sensing face	Switching output	Output function	Switching frequency f in Hz	Connection	Type	Order number
3		PNP		5000	Cable 2 m	MZF1-03VPS-KU0	7900596
3		PNP		5000	Cable 5 m	MZF1-03VPS-KUB	7903147
3		PNP		5000	Cable with M8 x 1 mm	MZF1-03VPS-KP0	7900597

Series is available as reed switch on request.



Magnetic cylinder sensors

MZT1 series

DC 3-wire, for T-slot cylinder

Dimensions in mm

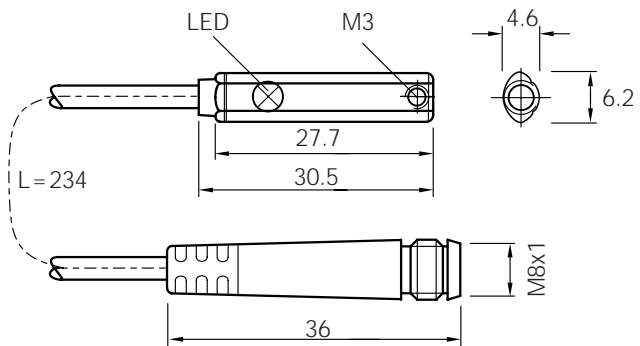

Features



- ▶ Non-contact detection of piston position in pneumatic cylinders
- ▶ **Mountable from the top**
- ▶ For all common used T-slot cylinder e.g. Festo, SMC
- ▶ Response sensitivity ≥ 3 mT
- ▶ Plastic housing with clamping screw
- ▶ Connection cable or connector on cable
- ▶ Enclosure rating IP 67
- ▶ LED status indicator
- ▶ Magneto-resistive element

Accessories

Round connector

Connection diagram

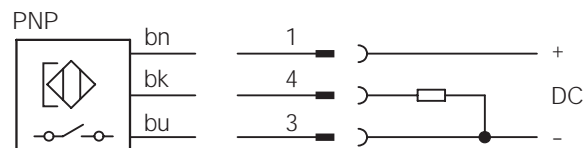



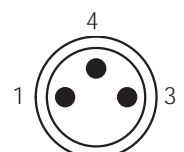

Wire colour	Contact	Assignment
bn brown	1	+ V DC
bk black	4	NO
bu blue	3	- V DC



Electrical and mechanical data

Operating voltage U_b	10 ... 30 V DC	Wire-break protection	yes
Ripple U_{ss}	$\leq 10\%$ of U_b	Short-circuit protection	yes
Voltage drop U_d	≤ 2 V	(pulsed)	
Power consumption (without load)	≤ 10 mA	Reverse polarity protection	yes
Continuous current I_a	≤ 100 mA	Power-up pulse suppression	yes
Time delay before availability t_v	≤ 2 ms	Enclosure rating to EN 60529	IP 67
Hysteresis H	$\leq 1,5$ mm	Shock and vibration stress	30 g, 11 ms 10 to 55 Hz, 1 mm
Repeatability R (U_b and T_a constant)	$\leq 0,2$ mm	Ambient temperature T_a	- 25 ... + 75 °C
EMC	to EN 60 947-5-2	Housing material	Plastic PA12
		Connection cable 2 m	PVC, 3 x 0,14 mm ²
		Connection cable with M8x1 mm	PUR

Selection table

Response sensitivity in mT	Sensing face	Switching-output	Output function	Switching frequency in Hz	Connection	Type	Order number
3		PNP		5000	Cable 2 m	MZT1-03VPS-KW0	1016809
3		PNP		5000	Cable w. M8 x 1 mm	MZT1-03VPS-KP0	1016910



Magnetic cylinder sensors

RZT1 series

Reed AC/DC 3-wire, for T-slot

Dimensions in mm

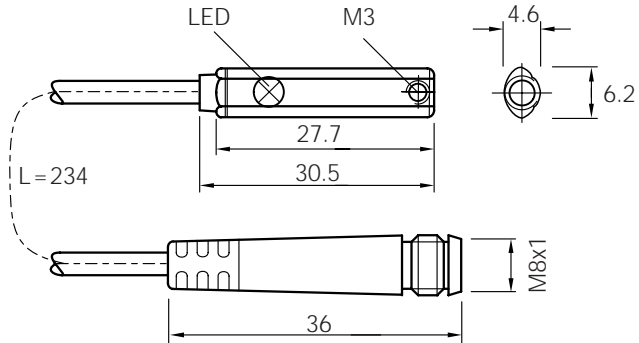

Features



- ▶ Non-contact detection of piston position in pneumatic cylinders
- ▶ **Mountable from the top**
- ▶ For all common used T-slot cylinder e.g. Festo, SMC
- ▶ Response sensitivity ≥ 3 mT
- ▶ Plastic housing with clamping screw
- ▶ Connection cable or connector on cable
- ▶ Enclosure rating IP 67
- ▶ LED status indicator

Accessories

Round connector

Connection diagramm

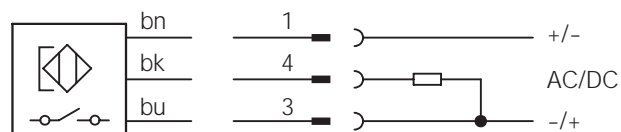

Wire colour	Contact	Assignment
bn brown	1	+ (-)
bk black	4	NO
bu blue	3	- (+)

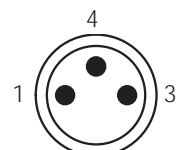





Electrical and mechanical data

Operating voltage U_b	10 ... 30 V AC/DC
Max. switching power	6 W / VA
Continuous current I_a	≤ 500 mA
Switching delay	ON app. 1,5 ms OUT app. 0,5 ms
Hysteresis H typ.	$\leq 1,5$ mm
Repeatability R (U_b und T_a constant)	$\leq 0,2$ mm
EMC	to EN 60 947-5-2

Enclosure rating to EN 60529	IP 67
Shock and vibration stress	30 g, 11 ms 10 to 55 Hz, 1 mm
Ambient temperature T_a	- 25 ... + 75 °C
Housing material	Plastic PA12
Connection cable 2 m	PVC, 3 x 0,14 mm ²
Connection cable with M8x1 mm connector	PUR

Selection table

Response sensitivity in mT	Sensing face	Version	Output-function	Switching frequency in Hz	Connection	Type	Order number
3		Reed		400	Cable 2 m	RZT1-03ZRS-KW0	1016911
3		Reed		400	Cable w. M8 x 1 mm	RZT1-03ZRS-KP0	1016912



Magnetic cylinder sensors

MZ U2 series

DC 3-wire, weld immune version

Dimensions in mm

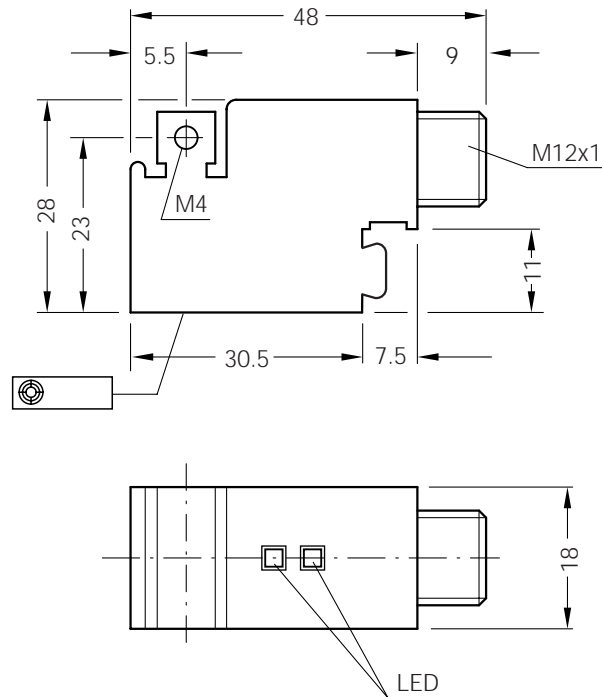

Features



- ▶ Non-contact detection of piston position in pneumatic cylinders in weld field environments
- ▶ Weld immune in all welding applications (AC, DC and medium frequency)
- ▶ Response sensitivity of interference field detector ≥ 2 mT
- ▶ The sensors locks the output during the welding process. When the welding process stops, the sensor updates the output accordingly
- ▶ Flexible mounting technique for different cylinder styles
- ▶ Solid metal housing in die-cast zinc, optional with teflon coating
- ▶ Actuating speed < 1 m/s
- ▶ 2 LED's
 Status indicator: yellow
 Function indicator: green

Accessories

Round connector
 Round connector welding splatter resistant

Connection diagram

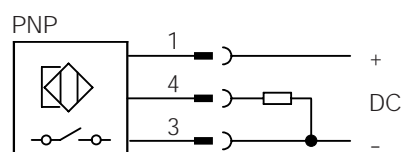

Contact	Assignment
1	+ V DC
4	NO
3	- V DC
2	free

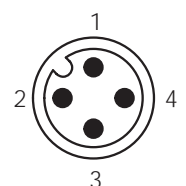

Electrical and mechanical data

Operating voltage U_b	10 ... 30 V DC	Wire-break protection	yes
Ripple U_{pp}	$\leq 10\%$ of U_b	Short-circuit protection (pulsed)	yes
Voltage drop U_d (at I_a max.)	≤ 2.0 V	Reverse polarity protection	yes
Power consumption	≤ 18 mA (unattenuated) ≤ 32 mA (attenuated)	Power-up pulse suppression	yes
Continuous current I_a	≤ 300 mA	Enclosure rating to DIN 60529	IP 67
Time delay before availability t_v	≤ 20 ms	Shock and vibration stress	30 g, 11 ms 10 to 55 Hz, 1 mm
Hysteresis H	≤ 1.5 mm	Ambient temperature T_a	- 25 ... + 75 °C
Repeatability R (U_b and T_a constant)	≤ 0.1 mm	Housing material	Die-cast zinc, optional with teflon coating
EMC	to EN 60 947-5-2		

Selection table

Response sensitivity in mT	Sensing face	Switching output	Output function	Switching frequency f in Hz	Connection	Type	Order number
3		PNP		40	Connector M12x1 mm	MZU2-03VPS-DCM	1017450
3		PNP		40	Connector M12x1 mm	MZU2-03VPS-TCM*	1017451

* with teflon coating

Accessories

Mounting clamp for pneumatic cylinder sensor MZU2

Mounting clamp: BEF-KS-U2-S1
Material: die-cast zinc
Order-No.: 4030922

Mounting clamp: BEF-KS-U2-S1T
Material: die-cast zinc with teflon coating
Order-No.: 4031632
Tie-rod cylinder $\varnothing 4 \dots 20$ mm

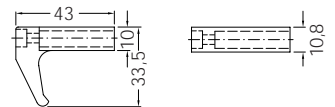

Mounting clamp: BEF-KS-U2-P1
Material: aluminium
Order-No.: 2019824
Integrated profile cylinder with max. rod diameter of 13 mm

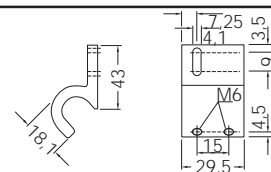

Mounting clamp: BEF-KS-U2-P2
Material: aluminium
Order-No.: 2019823
Integrated profile cylinder with max. rod diameter of 18 mm

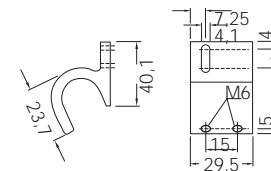

Mounting clamp: BEF-KS-U2-T1
Material: Aluminium
Order-No.: 2019822
Cylinder with T-slot

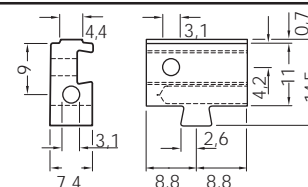



Magnetic cylinder sensors

MZ R2 series

NAMUR 2-wire, for round-body cylinders

Dimensions in mm

Features



- ▶ Non-contact determination of piston position in pneumatic cylinders
- ▶ Universal mounting with clamping band for max. cylinder diameter of 100 mm
- ▶ High response sensitivity ≥ 3 mT
- ▶ Frontal sensing face
- ▶ No secondary switching ranges
- ▶ High repeat accuracy
- ▶ Actuating speed ≤ 5 m/s
- ▶ NAMUR to EN 50 227
- ▶ Short-circuit protection
- ▶ Solid aluminium housing
- ▶ Cable or connector
- ▶ Enclosure rating IP 67
- ▶ LED status indicator

Classification

TÜV 99 ATEX 1398

EExibII CT6

Accessories

Round connectors

Isolating unit EN 2 Ex

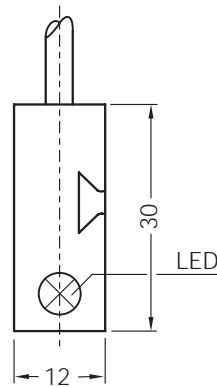
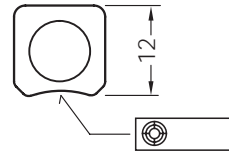

Connection diagram

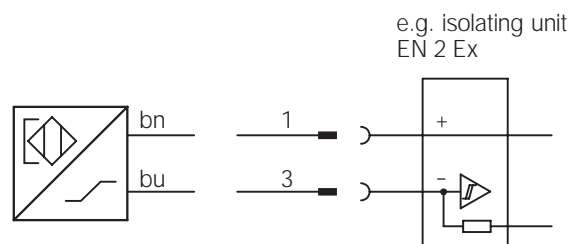

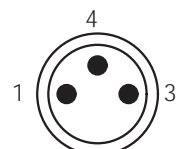

Wire colour	Contact	Assignment
bn brown	1	+ V DC
bu blue	3	- V DC
	4	free



Electrical and mechanical data

Operating voltage U_b	5 ... 25 V DC	Short-circuit protection	yes
Rated voltage U_n	8.2 V DC	Reverse polarity protection	yes
Ripple U_{pp}	$\leq 5\%$ of U_b	Enclosure rating to EN 60529	IP 67
Power consumption, attenuated	≥ 2.5 mA	Shock and vibration stress	30 g, 11 ms 10 to 55 Hz, 1 mm
Power consumption, unattenuated	≤ 1.0 mA	Ambient temperature T_a	- 25 ... + 70 °C
Internal capacitance	≤ 45 nF	Housing material	Aluminium, plastic
Internal inductance	≤ 30 μ H	Connection cable	PVC, 2 x 0.34 mm ² , blue
Cable resistance	≤ 50 ω		
Time delay before availability t_v	≤ 2 ms		
Hysteresis H	≤ 1.0 mm		
Repeatability R (U_b and T_a constant)	≤ 0.1 mm		
Temperature drift	± 0.005 mm / °C		
EMC	to EN 60 947-5-2		

Selection table

Response sensitivity in mT	Sensing face	Version	Output function	Switching frequency f in Hz	Connection	Type	Order number
3		NAMUR		5000	Cable 2 m	MZR2-03V-N-AW0	7901321

Accessories

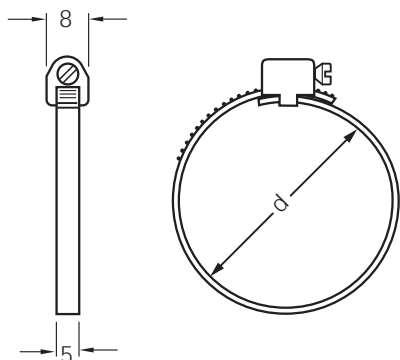

Clamping band

stainless steel
for magnetic cylinder sensor R2

For cylinder range with piston diameter	Clamping range d in mm	Type	Order-No.
8 ... 16 mm	18 - 29	BEF-S-R2-16	7901762
20/25 mm	28 - 39	BEF-S-R2-25	7901763
32 mm	38 - 49	BEF-S-R2-30	7901764
40 mm	48 - 59	BEF-S-R2-40	7901765
50 mm	58 - 69	BEF-S-R2-50	7901766
63 mm	68 - 79	BEF-S-R2-63	7901767
80 mm	88 - 99	BEF-S-R2-80	7901768
100 mm	98 - 109	BEF-S-R2-100	7901769

Magnetic cylinder sensors

MZ Z1 series

NAMUR 2-wire, for tie-rod cylinders

Dimensions in mm

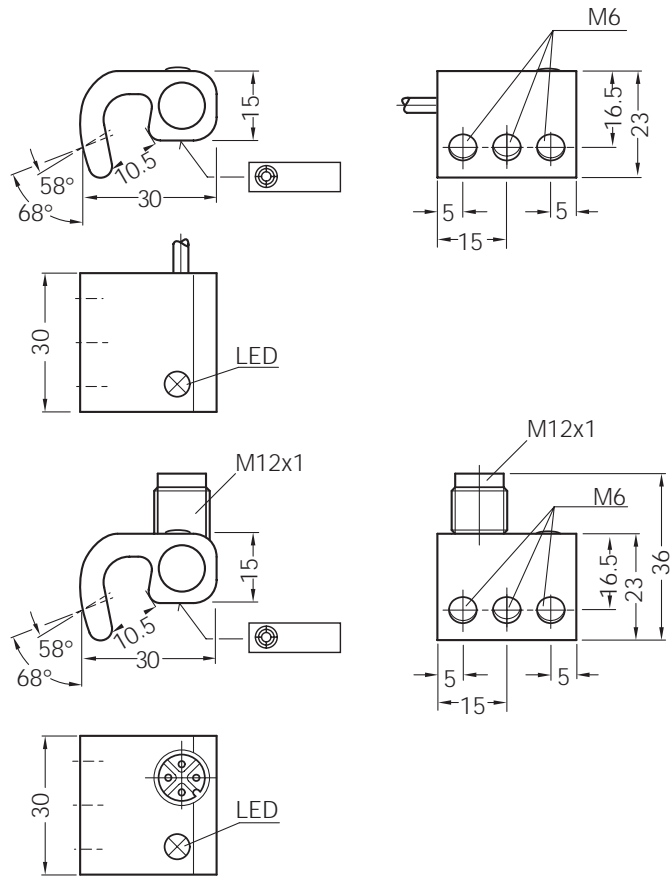

Features



- ▶ Non-contact determination of piston position in pneumatic cylinders
- ▶ Mounting of tie-rods with max. rod diameter of 10 mm
- ▶ High response sensitivity ≥ 3 mT
- ▶ Frontal sensing face
- ▶ No secondary switching ranges
- ▶ High repeat accuracy
- ▶ Actuating speed ≤ 5 m/s
- ▶ NAMUR to EN50 227
- ▶ Solid aluminium construction with integrated mounting claw
- ▶ Cable or connector
- ▶ Enclosure rating IP 67
- ▶ LED status indicator
- ▶ **Classification**
TÜV 99 ATEX 1398
Ex EExibII CT6

Accessories

Round connectors

Connection diagram

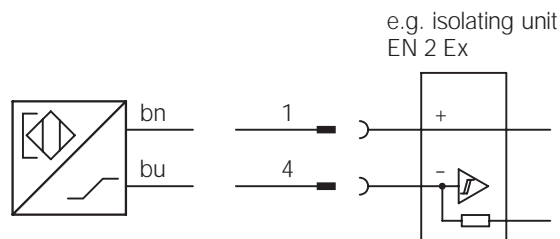



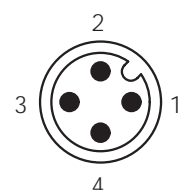

Wire colour	Contact	Assignment
bn brown	1	+ V DC
bu blue	4	- V DC
	2	free
	3	free



Electrical and mechanical data

Operating voltage U_b	5 ... 25 V DC	Short-circuit protected	yes
Rated voltage U_n	8.2 V DC	Reverse polarity protected	yes
Ripple U_{pp}	$\leq 5\%$ of U_b	Enclosure rating to EN 60529	IP 67
Power consumption, attenuated	≥ 2.5 mA	Shock and vibration stress	30 g, 11 ms 10 to 55 Hz, 1 mm
Power consumption, unattenuated	≤ 1.0 mA	Ambient temperature T_a	- 25 ... + 70 °C
Internal capacitance	≤ 45 nF	Housing material	Aluminium, plastic
Internal inductance	≤ 30 μ H	Connection cable	PVC, 2 x 0.34 mm ² , blue
Cable resistance	≤ 50 ω		
Time delay before availability t_v	≤ 2 ms		
Hysteresis H	≤ 1.0 mm		
Repeatability R (U_b and T_a constant)	≤ 0.1 mm		
Temperature drift	± 0.005 mm / °C		
EMC	to EN 60 947-5-2		

Selection table

Response sensitivity in mT	Sensing face	Version	Output function	Switching frequency f in Hz	Connection	Type	Order number
3		NAMUR		5000	Cable 2 m	MZZ1-03V-N-AW0	7901323
3		NAMUR		5000	Connector M12 x 1 mm	MZZ1-03V-N-AC0	7901324

Magnetic cylinder sensors

MZ P3 series

NAMUR 2-wire, for integrated profile cylinders

Dimensions in mm

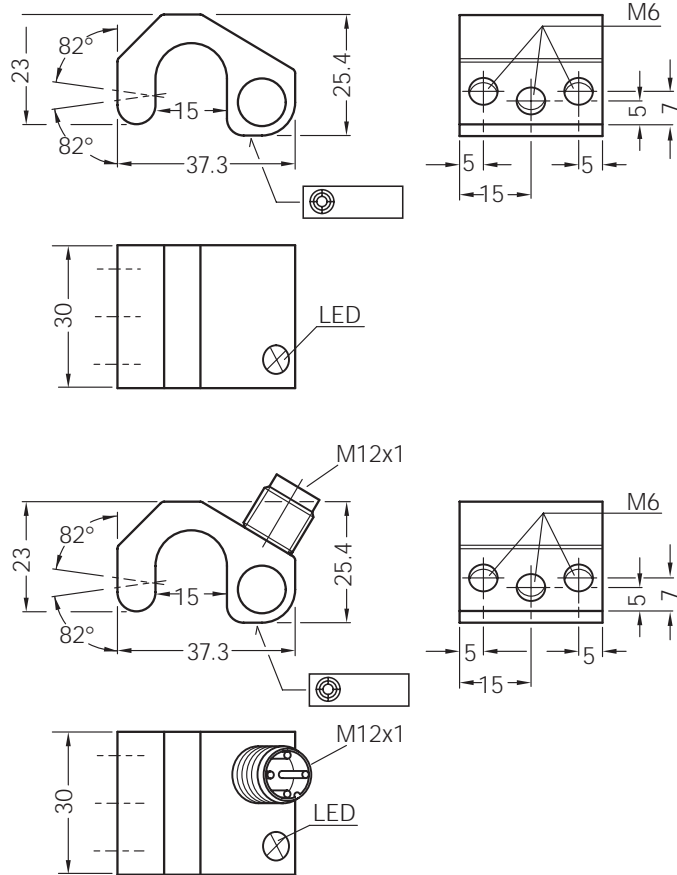

Features



- ▶ Non-contact determination of piston position in pneumatic cylinders
- ▶ Mounting on integrated profile with max. width of 14 mm
- ▶ High response sensitivity ≥ 3 mT
- ▶ Frontal sensing face
- ▶ No secondary switching ranges
- ▶ High repeat accuracy
- ▶ Actuating speed ≤ 5 m/s
- ▶ NAMUR to EN 50 227
- ▶ Solid aluminium housing with integrated mounting claw
- ▶ Cable or connector
- ▶ Enclosure rating IP 67
- ▶ LED status indicator

▶ **Classification**
TÜV 99 ATEX 1398
(Ex) EExibII CT6

Accessories

Round connectors
 Isolating unit EN 2 Ex

Connection diagram

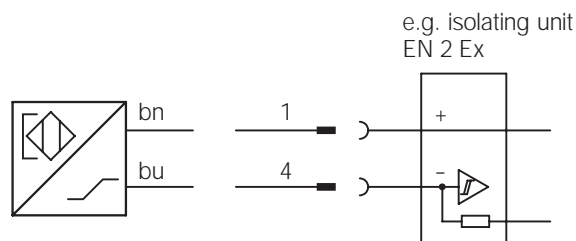



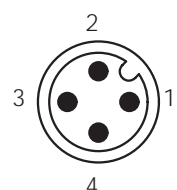

Wire colour	Contact	Assignment
bn brown	1	+ V DC
bu blue	4	- V DC
	2	free
	3	free



Electrical and mechanical data

Operating voltage U_b	5 ... 25 V DC	Short-circuit protected	yes
Rated voltage U_n	8.2 V DC	Reverse polarity protected	yes
Ripple U_{pp}	$\leq 5\%$ of U_b	Enclosure rating to EN 60529	IP 67
Power consumption, attenuated	≥ 2.5 mA	Shock and vibration stress	30 g, 11 ms 10 to 55 Hz, 1 mm
Power consumption, unattenuated	≤ 1.0 mA	Ambient temperature T_a	- 25 ... + 70 °C
Internal capacitance	≤ 45 nF	Housing material	Aluminium, plastic
Internal inductance	≤ 30 μ H	Connection cable	PVC, 2 x 0.34 mm ² , blue
Cable resistance	≤ 50 ω		
Time delay before availability t_v	≤ 2 ms		
Hysteresis H	≤ 1.0 mm		
Repeatability R (U_b and T_a constant)	≤ 0.1 mm		
Temperature drift	± 0.005 mm / °C		
EMC	to EN 60 947-5-2		

Selection table

Response sensitivity in mT	Sensing face	Version	Output function	Switching frequency f in Hz	Connection	Type	Order number
3		NAMUR		5000	Cable 2 m	MZP3-03V-N-AW0	7901440
3		NAMUR		5000	Connector M12 x 1 mm	MZP3-03V-N-AC0	7901441

Magnetic cylinder sensors

MZ P4 series

NAMUR 2-wire, for integrated profile cylinders

Dimensions in mm

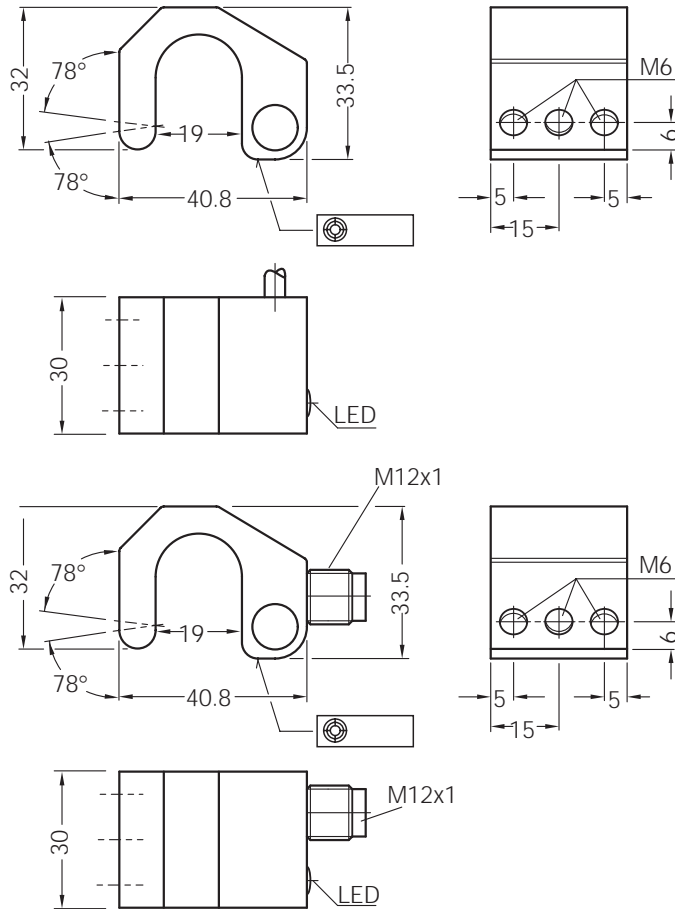

Features



- ▶ Non-contact determination of piston condition in pneumatic cylinders
- ▶ Mounting on integrated profile with max. width of 18 mm
- ▶ High response sensitivity ≥ 3 mT
- ▶ Frontal sensing face
- ▶ No secondary switching ranges
- ▶ High repeat accuracy
- ▶ Actuating speed ≤ 5 m/s
- ▶ NAMUR to DIN19234
- ▶ Solid aluminium housing with integrated mounting claw
- ▶ Cable or connector
- ▶ Enclosure rating IP 67
- ▶ LED status indicator
- ▶ **Classification**
TÜV 99 ATEX 1398
Ex EExibII CT6

Accessories

- Round connectors
- Isolating unit EN 2 Ex

Connection diagram

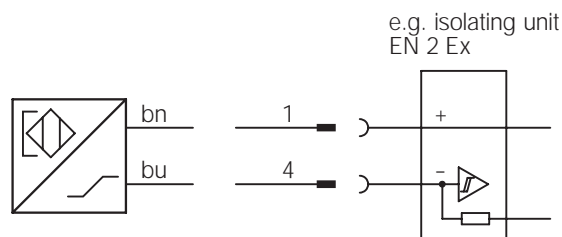



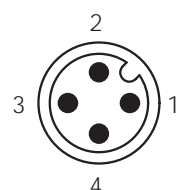

Wire colour	Contact	Assignment
bn brown	1	+ V DC
bu blue	4	- V DC
	2	free
	3	free



Electrical and mechanical data

Operating voltage U_b	5 ... 25 V DC	Short-circuit protected	yes
Rated voltage U_n	8.2 V DC	Reverse polarity protected	yes
Ripple U_{pp}	$\leq 5\%$ of U_b	Enclosure rating to EN 60529	IP 67
Power consumption, attenuated	≥ 2.5 mA	Shock and vibration stress	30 g, 11 ms 10 to 55 Hz, 1 mm
Power consumption, unattenuated	≤ 1.0 mA	Ambient temperature T_a	- 25 ... + 70 °C
Internal capacitance	≤ 45 nF	Housing material	Aluminium, plastic
Internal inductance	≤ 30 μ H	Connection cable	PVC, 2 x 0.34 mm ² , blue
Cable resistance	≤ 50 ω		
Time delay before availability t_v	≤ 2 ms		
Hysteresis H	≤ 1.0 mm		
Repeatability R (U_b and T_a constant)	≤ 0.1 mm		
Temperature drift	± 0.005 mm / °C		
EMC	to EN 60 947-5-2		

Selection table

Response sensitivity in mT	Sensing face	Version	Output function	Switching frequency f in Hz	Connection	Type	Order number
3		NAMUR		5000	Cable 2 m	MZP4-03V-N-AW0	7901329
3		NAMUR		5000	Connector M12 x 1 mm	MZP4-03V-N-AC0	7901330

Accessories Control unit EN 2

Dimensions in mm

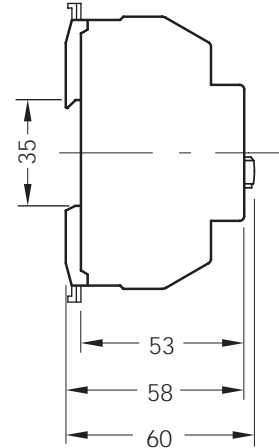
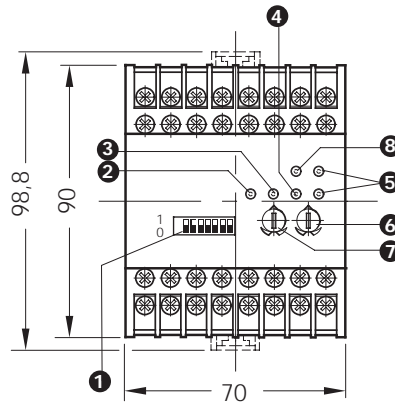

Features



- ▶ Universal supply voltage
- ▶ 3 inputs
- ▶ VDE protection class II
- ▶ Power-on indication
- ▶ Status indicator
- ▶ Housing with snap-on mounting for support rail DIN 46277
- ▶ Adjustable response delay
- ▶ Adjustable release delay

- ❶ DIP switches F 1...8
- ❷ Indicator IN 1
- ❸ Indicator IN 2
- ❹ Indicator IN 3
- ❺ Indicator OUT
- ❻ Release delay
- ❼ Response delay
- ❽ Power indicator

Connection diagram

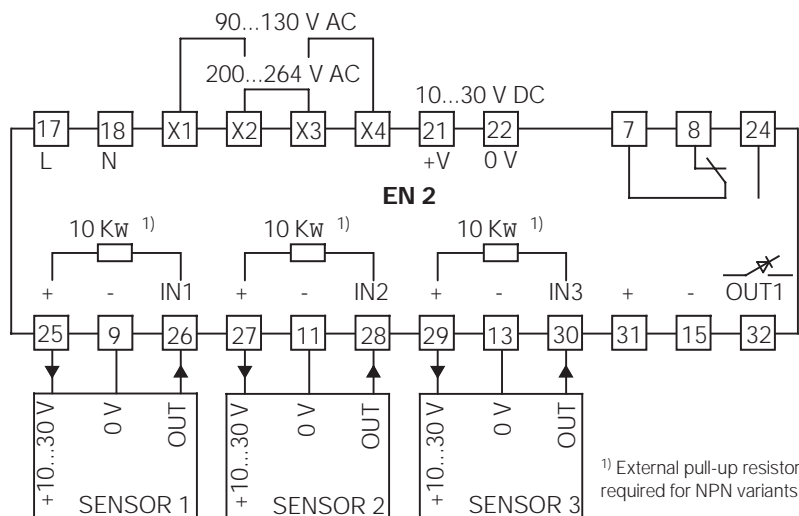
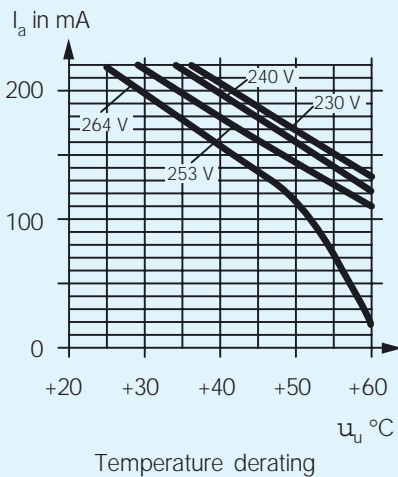

Technical data

Operating voltage U_b	90...130 V AC or 200...264 V AC; 10...30 V DC ²⁾
System frequency	48...62 Hz
Power consumption	approx. 40 VA
Outputs	
Rated supply voltage	24 V DC \pm 25%
Output current (total) I_a	220 mA, see temperature derating curve
Transistor output	Terminal 32 (OUT 1)
Type	PNP
Switching current	\leq 100 mA, short-circuit protected, LED flashes if short-circuit occurs
Switching frequency	10 kHz
Relay output	Terminals 7, 8, 24
Switching voltage	\leq 250 V AC
Switching current	\leq 2 A
Switching frequency	10 Hz
Inputs	Terminals 26 (IN 1) and 28 (IN 2) and 30 (IN 3), suitable for PNP, NPN ¹⁾ and B sensor outputs
Input voltage	10...30 V DC
HIGH	$>$ 10 V DC
LOW	$<$ 6 V DC
Min. power-up time	$>$ 5 μ s
Time delays, logics	See Truth table/Functional diagrams/ t_1 , t_2 : adjustable from 0.005 to 1 s
VDE protection class	\square
Enclosure rating to DIN 40050	IP 20
Ambient temperature T_a	-25...+55 °C
Storage temperature	-40...+70 °C
Shock, vibration	IEC 68, Part 2...6
EMC	IEC 801
Weight	approx. 400 g

1) External pull-up resistor 10k Ω required for NPN variant

2) When supplied: AC 200...264 V, can be upgraded using jumpers

Order No. 6009654

Overview of functions

F3	0	IN 1 normal		
	1	IN 1 inverse		
F5	0	$f(\text{IN } 1, \text{IN } 2) = \text{IN } 1 \div \text{IN } 2$		
	1	$f(\text{IN } 1, \text{IN } 2) = \text{IN } 1 \times \text{IN } 2$		
F7	0	IN 2 normal		
	1	IN 2 inverse		
F8	0		$\nabla(\text{F } 8 = 0)$	
	1			$\nabla(\text{F } 8 = 1)$
F6	0	$f(\text{IN } 1, \text{IN } 2, \text{IN } 3) = \text{IN } 3 \div f(\text{IN } 1, \text{IN } 2)$	IN 3 normal	
	1	$f(\text{IN } 1, \text{IN } 2, \text{IN } 3) = \text{IN } 3 \times f(\text{IN } 1, \text{IN } 2)$	IN 3 inverse	
F4	0	OUT normal	$\nabla(\text{F } 4 = 0)$	
	1	OUT inverse		$\nabla(\text{F } 4 = 1)$
F1	0	No delay	Mo 1	Mo 1
	1	Response and release delay	Mo 2	Mo 2
F2	0	Dynamically delayed	Mo 3	Mo 3
	1	Frequency discriminator	Mo 4	Mo 4

F8 = 0

F1 = 0 F2 = 0

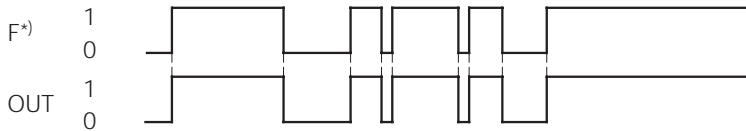

The output OUT follows F* (the logic operation for inputs IN1, IN 2, and IN 3) without delay.

F1 = 0 F2 = 1

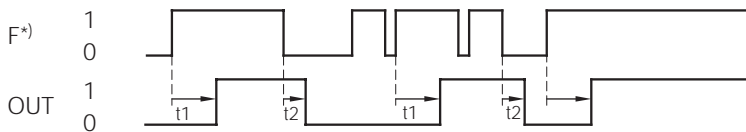

The output OUT follows F* with a response and release delay. F* must be high for at least t_1 so that OUT reacts. t_1 is reset by low of F*. OUT responds when t_1 has elapsed, oscillator f . t_1 is stopped. If F* is then low again, t_2 begins to run after which OUT becomes inactive. If F* runs high again during t_2 , t_2 is reset and begins to run again when F* = low. Both times, t_1 and t_2 , can therefore be retrIGGERED.

F1 = 1 F2 = 0

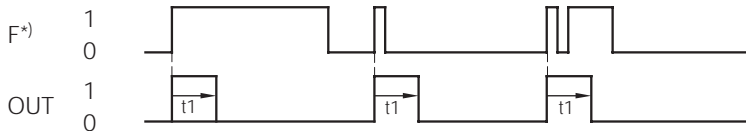

The output OUT has a rising edge from F* for the duration of t_1 . This time cannot be retrIGGERED here.

F1 = 1 F2 = 1

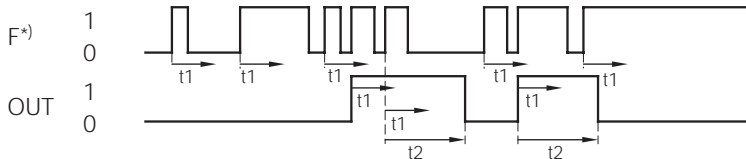

The time delay t_1 is started with the first rising edge of F*. If a further rising edge along F* occurs within t_1 , OUT is set for the duration of t_2 and time delay t_1 is simultaneously retrIGGERED. All subsequent rising edges along F*, if they occur during t_1 , retrigger both t_1 and t_2 . t_2 must usually be set greater than t_1 . If t_1 (but not t_2) has elapsed, t_2 is not retrIGGERED by the next rising edge along F*.

With the setting $t_2 \geq t_1$, this function provides a frequency discriminator: If the period T of the input frequency along F* is less than t_1 , OUT remains set to high; if T is or becomes greater than t_1 , OUT remains or becomes low.

F* logic operation of inputs: $F = f(\text{IN } 1, \text{IN } 2, \text{IN } 3)$

Overview of functions

F8 = 1 F4 = 0
F1 = 0 F2 = 0
Mo 1

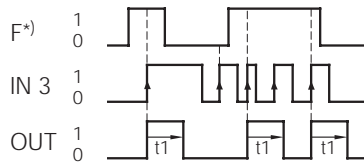

If during the rising edge of IN 3 the operation F* is high, this edge sets the output OUT for the time t1.

F1 = 0 F2 = 1
Mo 2

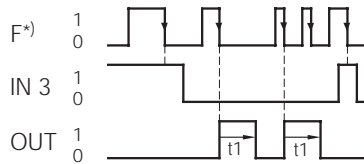

If during the falling edge of F* IN 3 is not high, the output is set for the duration of t1.

F1 = 1 F2 = 0
Mo 3

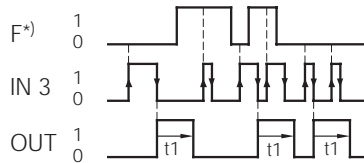

If F* is not high with a rising edge along IN 3, the falling edge of IN 3 sets the output for the time t1.

F1 = 1 F2 = 1
Mo 4

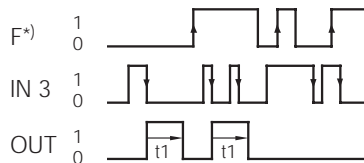

If no rising edge along F* occurs during the high time of IN 3, at the falling edge of IN 3 the output is set for the duration of t1.

F4 = 1
F1 = 0 F2 = 0
Mo 1

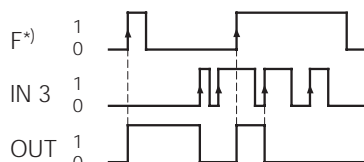

A rising edge along F* sets the output; a rising edge along IN 3 resets it. (Edge-controlled RS-flipflop)

F1 = 1 F2 = 1
Mo 2

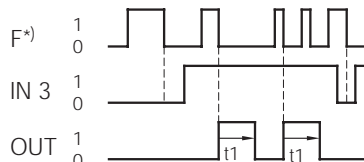

If during the falling edge of F* IN 3 is high, the output is set for the duration of t1. (I.e. as for Mo 2, only IN 3 used as inverse)

F1 = 1 F2 = 0
Mo 3

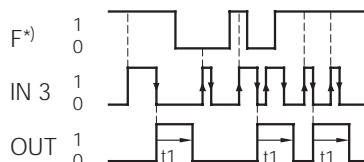

If F* was high with a rising edge along IN 3, the falling edge along IN 3 sets the output for the time t1. (As for Mo 3, F* used as inverse)

F1 = 1 F2 = 1
Mo 4

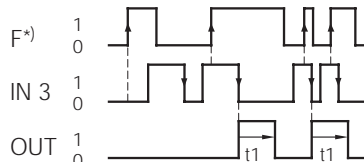

If during the high-time of IN 3 a rising edge along F* occurs, with the falling edge of IN 3 the output is set for the duration of t1.

Accessories Isolating unit EN 2 Ex

Dimensions in mm

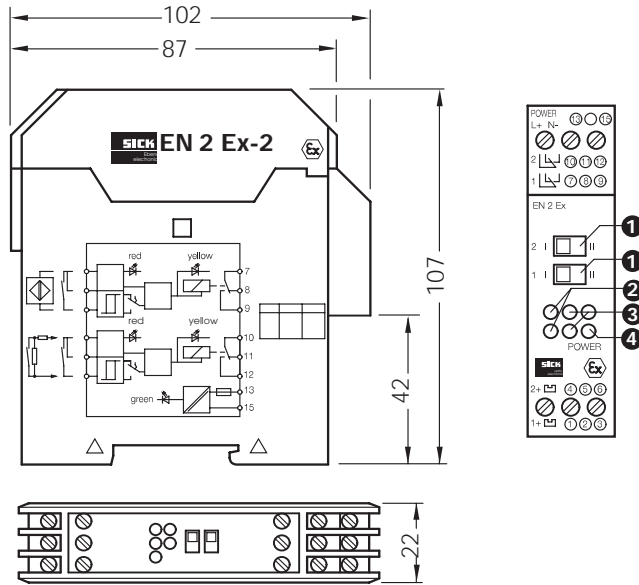

Features



- ▶ Reliable electrical isolation between input, output, and supply voltage to VDE 0100 Part 410
- ▶ 2-channel each with one relay output 1 x u
- ▶ Invertible outputs
- ▶ Conformity certificate PTB-No. EX.-95.C.20003X
- ▶ Intrinsically safe inputs to [EEx ia] IIC
- ▶ Power-on and status indicators
- ▶ Housing with snap-on mounting for support rail DIN 46277
- ▶ Suitable for zone 0, FRG: 1

Description of operating elements

- ❶ Switch to reverse action
Switch in position I and contact in input circuit closed, output active (ON).
Switch in position II, output action inverted.
- ❷ LED (red), cable monitoring indicator.
Activation of cable-break and cable-short-circuit monitoring is only functional if a proximity switch to DIN 50227 or NAMUR, or a mechanical contact with suitable resistance circuit as per the operating instructions is connected. This circuit monitors the input current and deactivates the output with input currents < 0.3 mA cable-break / and > 6.5 mA short-circuit - irrespective of the setting for the direction of action.
- ❸ LED (yellow), status indicator.
This LED is actuated at the same time as the output.
- ❹ LED (green), voltage supply indicator.

Connection diagram

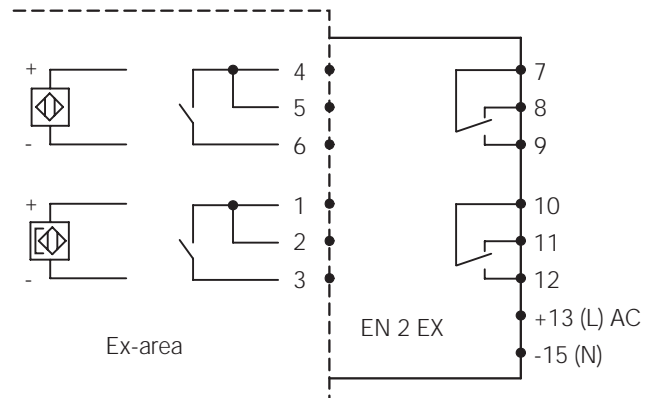

Technical data EN 2 Ex

	-1	-2	-3
Part No.	6010459	6010460	6009944
Supply voltage V_s	AC 115 V	AC 230 V	DC 24 V
Power frequency	48 to 62 Hz		-
Line consumption	approx. 1.5 VA per channel		0.7 W
Inputs	for 1 or 2 sensors		
Idling voltage	DC 8.5 V		
Switching points	$0 I \leq 1.55 \text{ mA}$, $1 I \geq 1.75 \text{ mA}$		
Short-circuit current	$I \geq 6 \text{ mA}$		
Permitted external capacity	max. 567 nF		
Permitted external inductivity	max. 5 mH		
Switching outputs ¹⁾	One relay per input: 1 x u		
Switching voltage U max.	AC 250 V		
Switching current I max.	5A		
Switching capacity P max.	100 VA		
Explosion protection	[EEx ia] IIC		
VDE protection class	I		
Degree of protection	IP 20		
Ambient operating temperature T_u	-25 to +60 °C		
Storage temperature	-25 to +85 °C		
Weight	250 g		

1) Intended as spark suppression suitable for inductive or capacitive load

Transmission behaviour

Direction of action: reversible (see table)
 Line monitoring: can be deactivated
 Max. switching frequency: 20 Hz

Switching function table

Input		Direction of action	Cable monitoring	Relay	Switching status, yellow LED	Cable monitoring, red LED
Without fault in input circuit	Ind. proximity sensor attenuated Magn. proximity sensor unattenuated	Normal	Any	Released	Off	Off
	Ind. proximity sensor unattenuated Magn. proximity sensor attenuated	Normal	Any	Picked up	On	Off
	Ind. proximity sensor attenuated Magn. proximity sensor unattenuated	Inverse	Any	Picked up	On	Off
	Ind. proximity sensor unattenuated Magn. proximity sensor attenuated	Inverse	Any	Released	Off	Off
With fault in input circuit	Cable-break	Normal	On	Released	Off	On
	Cable-break	Inverse	On	Released	Off	On
	Short-circuit	Normal	On	Released	Off	On
	Short-circuit	Inverse	On	Released	Off	On
	Cable-break	Normal	Off	Released	Off	Off
	Cable-break	Inverse	Off	Picked up	On	Off
	Short-circuit	Normal	Off	Picked up	On	Off
	Short-circuit	Inverse	Off	Released	Off	Off

Accessories

Round connectors adjustable

Cable receptacle, straight design

DOS-0803-G
M8 Order-No. 7902077
 connectable cable: \varnothing 4-5 mm / 0,25 mm²; 0,34 mm²

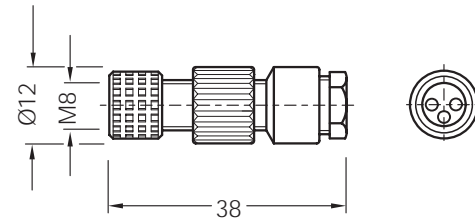

DOS-1204-G
M12 Order-No. 6007302
 connectable cable: \varnothing 4-6 mm / max. 0,75 mm²

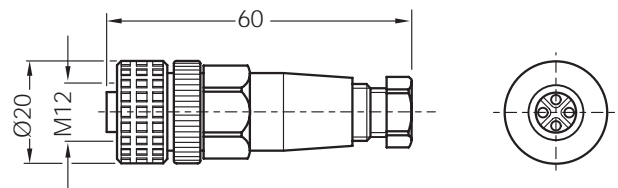

Cable receptacle, angled design

DOS-0803-W
M8 Order-No. 7902078
 connectable cable: \varnothing 4-5 mm / 0,25 mm²; 0,34 mm²

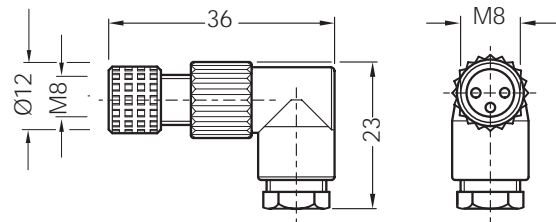

DOS-1204-W
M12 Order-No. 6007303
 connectable cable: \varnothing 4-6 mm / max. 0,75 mm²

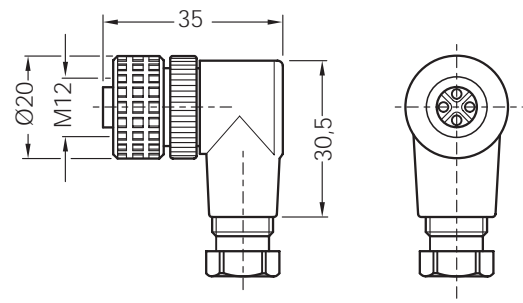

Accessories

Round connectors with integral cable

Straight design

DOL-0803-G02M

PVC, 3 x 0,25 mm², 2 m

M8 Order-No. 6010785

DOL-0803-G05MB

PUR, 3 x 0,25 mm², 5 m

M8 Order-No. 7902080

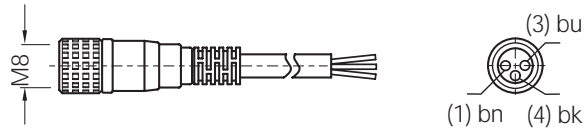

DOL-1204-G02M

PVC, 4 x 0,25 mm², 2 m

M12 Order-No. 6009382

DOL-1204-G05M

PVC, 4 x 0,25 mm², 5 m

M12 Order-No. 6009866

DOL-1204-G05MB

PUR, 3 x 0,34 mm², 5 m

M12 Order-No. 7902084

DOL-1204-G10M

PVC, 4 x 0,25 mm², 10 m

M12 Order-No. 6010543

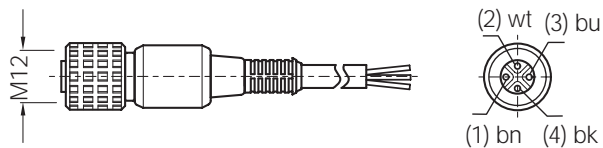

Angled design

DOL-0803-W02M

PVC, 3 x 0,25 mm², 2 m

M8 Order-No. 6008489

DOL-0803-W05MB

PUR, 3 x 0,25 mm², 5 m

M8 Order-No. 7902081

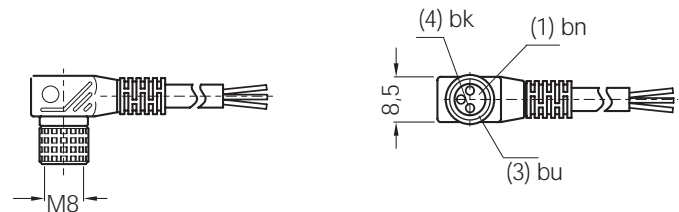

DOL-1204-W02M

PVC, 4 x 0,25 mm², 2 m

M12 Order-No. 6009383

DOL-1204-W05M

PVC, 4 x 0,25 mm², 5 m

M12 Order-No. 6009867

DOL-1204-W05MD

PVC, 4 x 0,34 mm², 5 m, welding splatter resistant

M12 Order-No. 6020399

DOL-1204-W05MB

PUR, 3 x 0,34 mm², 5 m

M12 Order-No. 7902085

DOL-1204-W10M

PVC, 4 x 0,25 mm², 10 m

M12 Order-No. 6010541

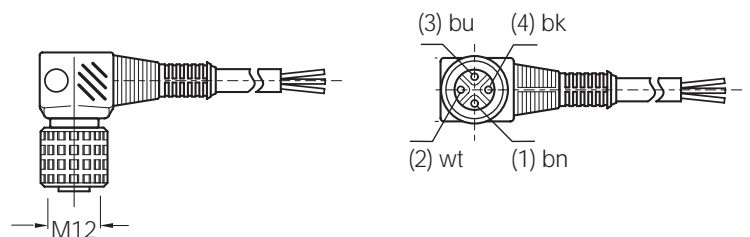

DOL-1204-W05ME

PUR/PVC, 4 x 0,34 mm², 5 m

with LED's for power and output indication,
PNP-complementary

M12 Order-No. 6020398

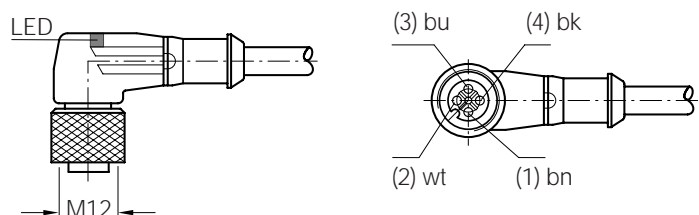

Accessories

Magnets

Magnet M 1.0

MAG-1003-S, Samarium cobalt
temperature resistance
-50 °C to +180 °C

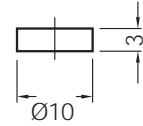

Order-No. 7901782

Magnet M 2.0

MAG-0625-A, AlNiCo
temperature resistance
-100 °C to +450 °C

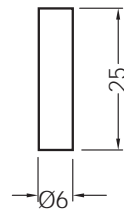

Order-No. 7901783

Magnet M 3.0

MAG-2006-B, Barium ferrite
temperature resistance
-25 °C to +130 °C

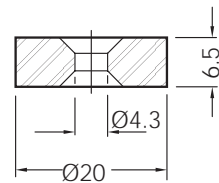

Order-No. 7901784

Magnet M 4.0

MAG-3010-B, Barium ferrite
temperature resistance
-25 °C to +130 °C

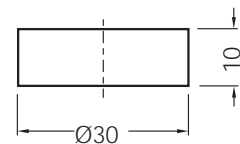

Order-No. 7901785

Magnet M 5.0

MAG-3015-B, Barium ferrite
temperature resistance
-25 °C to +130 °C

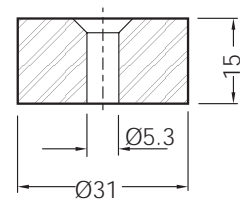

Order-No. 7901786

Magnet M 5.1

MAG-3515-B, Barium ferrite with
plastic jacket

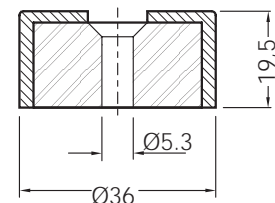

Order-No. 7902086

Accessories

Mounting brackets

BEF-WN-M12 Mounting bracket for M12 (M3 screws not included)

metal

Order-No. 5308447

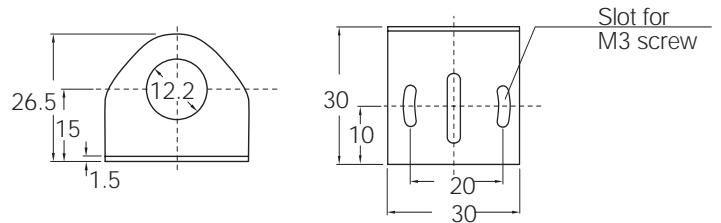

BEF-WN-M18 Mounting bracket for M18 (M4 screws not included)

metal

Order-No. 5308446

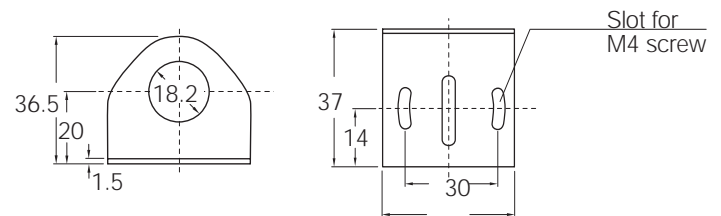

BEF-WN-M30 Mounting bracket for M30 (M5 screws not included)

metal

Order-No. 5308445

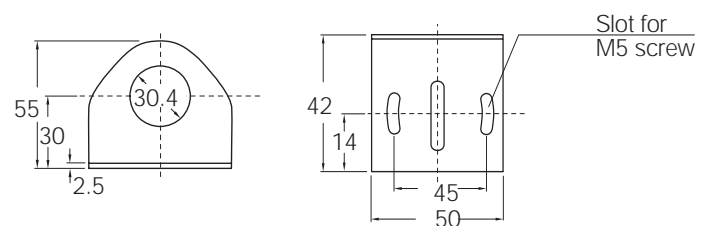

Index

Type designation

Type designation	Order No.	Page	Type designation	Order No.	Page
CM 18 - 08B P P - K C 1	6020388	108	IM 08 - 04N N O - Z T 1	7900016	28
CM 18 - 08B P P - K W 1	6020136	108	IM 08 - 04N N S - Z T 1	7900014	28
CM 18 - 12N P P - K C 1	6020410	108	IM 08 - 04N N S - Z W 1	7900010	28
CM 18 - 12N P P - K W 1	6020389	108	IM 08 - 04N P O - Z T 1	7900015	28
CM 30 - 16B P P - K C 1	6020475	110	IM 08 - 04N P O - Z W 1	7900011	28
CM 30 - 16B P P - K W 1	6020473	110	IM 08 - 04N P S - Z T 1	7900013	28
CM 30 - 25N P P - K C 1	6020477	110	IM 08 - 04N P S - Z W 1	7900009	28
CM 30 - 25N P P - K W 1	6020476	110	IM 08 - 1B5 N O - Z W 1	6020218	24
CQ 35 - 25N P P - K C 1	6020479	112	IM 08 - 1B5 N S - Z C 1	6020224	24
CQ 35 - 25N P P - K W 1	6020478	112	IM 08 - 1B5 N S - Z T 1	6020220	24
IH 03 - 0B6 N S - V U 1	6020142	56	IM 08 - 1B5 N S - Z T K	6020176	26
IH 03 - 0B6 P S - V U 1	6020141	56	IM 08 - 1B5 N S - Z W 1	6020216	24
IH 04 - 0B8 N S - V T 1	6020152	58	IM 08 - 1B5 N S - Z W K	6020173	26
IH 04 - 0B8 N S - V W 1	6020149	58	IM 08 - 1B5 P O - Z T 1	6020221	24
IH 04 - 0B8 P S - V T 1	6020114	58	IM 08 - 1B5 P O - Z W 1	6020217	24
IH 04 - 0B8 P S - V W 1	6020113	58	IM 08 - 1B5 P S - Z C 1	6020223	24
IH 06 - 02B N S - V T 1	7900180	62	IM 08 - 1B5 P S - Z T 1	6020219	24
IH 06 - 02B N S - V W 1	7900178	62	IM 08 - 1B5 P S - Z T K	6020112	26
IH 06 - 02B P S - V T 1	7900179	62	IM 08 - 1B5 P S - Z W 1	6020215	24
IH 06 - 02B P S - V W 1	7900177	62	IM 08 - 1B5 P S - Z W K	6020111	26
IH 06 - 04N N S - V T 1	7900184	62	IM 08 - 2N5 N S - Z C 1	6020236	24
IH 06 - 04N N S - V W 1	7900182	62	IM 08 - 2N5 N S - Z T 1	6020232	24
IH 06 - 04N P S - V T 1	7900183	62	IM 08 - 2N5 N S - Z W 1	6020228	24
IH 06 - 04N P S - V W 1	7900181	62	IM 08 - 2N5 P S - Z C 1	6020235	24
IH 06 - 1B5 N S - V T K	6020170	60	IM 08 - 2N5 P S - Z T 1	6020231	24
IH 06 - 1B5 N S - V W K	6020166	60	IM 08 - 2N5 P S - Z W 1	6020227	24
IH 06 - 1B5 P S - V T K	6020169	60	IM 12 - 04B N S - Z C 1	7900038	34
IH 06 - 1B5 P S - V W K	6020165	60	IM 12 - 04B N S - Z W 1	7900034	34
IH 20 - 10N U O - K U 0	7902131	90	IM 12 - 04B P O - Z C 1	7900039	34
IH 20 - 10N U S - K U 0	7902130	90	IM 12 - 04B P O - Z W 1	7900035	34
IH 34 - 30N U O - K U 0	7902135	92	IM 12 - 04B P S - Z C 1	7900037	34
IH 34 - 30N U S - K U 0	7902134	92	IM 12 - 04B P S - Z W 1	7900033	34
IM 04 - 0B6 N S - Z U 1	6020146	20	IM 12 - 08N N O - Z W 1	7900044	34
IM 04 - 0B6 P S - Z U 1	6020145	20	IM 12 - 08N N S - Z C 1	7900046	34
IM 05 - 0B8 N S - Z T 1	6020158	22	IM 12 - 08N N S - Z W 1	7900042	34
IM 05 - 0B8 N S - Z W 1	6020155	22	IM 12 - 08N P O - Z C 1	7900047	34
IM 05 - 0B8 P S - Z T 1	6020110	22	IM 12 - 08N P O - Z W 1	7900043	34
IM 05 - 0B8 P S - Z W 1	6011591	22	IM 12 - 08N P S - Z C 1	7900045	34
IM 08 - 01B - N - Z W 0	6021123	98	IM 12 - 08N P S - Z W 1	7900041	34
IM 08 - 02B N O - Z T 1	7900008	28	IM 12 - 02B A O - Z U 0	7902119	84
IM 08 - 02B N S - Z T 1	7900006	28	IM 12 - 02B A S - Z U 0	7902118	84
IM 08 - 02B N S - Z W 1	7900002	28	IM 12 - 02B C P - Z C 1	7902928	38
IM 08 - 02B P O - Z T 1	7900007	28	IM 12 - 02B C P - Z W 1	7902927	38
IM 08 - 02B P O - Z W 1	7900003	28	IM 12 - 02B D S - Z C 1	6020312	78
IM 08 - 02B P S - Z T 1	7900005	28	IM 12 - 02B D S - Z W 1	6020310	78
IM 08 - 02B P S - Z W 1	7900001	28	IM 12 - 02B N O - Z C 1	6011974	30

Index

Type designation

Type designation	Order No.	Page	Type designation	Order No.	Page
IM 12 - 02B N O - Z W 1	6011966	30	IM 18 - 05B N S - Z W 1	6011988	40
IM 12 - 02B N P - Z C 1	7902924	36	IM 18 - 05B - N - Z W 0	6021126	102
IM 12 - 02B N S - Z C 1	6011972	30	IM 18 - 05B P O - Z C 1	6011993	40
IM 12 - 02B N S - Z C K	1017440	32	IM 18 - 05B P O - Z W 1	6011989	40
IM 12 - 02B N S - Z T 1	6011968	30	IM 18 - 05B P P - Z C 1	7902931	46
IM 12 - 02B N S - Z U K	1017438	32	IM 18 - 05B P S - Z C 1	6011991	40
IM 12 - 02B N S - Z W 1	6011964	30	IM 18 - 05B P S - Z C K	1017432	42
IM 12 - 02B - N - Z W 0	6021124	100	IM 18 - 05B P S - Z U K	1017430	42
IM 12 - 02B P O - Z C 1	6011973	30	IM 18 - 05B P S - Z W 1	6011987	40
IM 12 - 02B P O - Z W 1	6011965	30	IM 18 - 05B U O - Z U 0	7902123	86
IM 12 - 02B P P - Z C 1	7902923	36	IM 18 - 05B U S - Z U 0	7902122	86
IM 12 - 02B P S - Z C 1	6011971	30	IM 18 - 08B N S - Z C 1	7900086	44
IM 12 - 02B P S - Z C K	1017428	32	IM 18 - 08B N S - Z W 1	7900082	44
IM 12 - 02B P S - Z T 1	6011967	30	IM 18 - 08B P O - Z C 1	7900087	44
IM 12 - 02B P S - Z U K	1017426	32	IM 18 - 08B P O - Z W 1	7900083	44
IM 12 - 02B P S - Z W 1	6011963	30	IM 18 - 08B P S - Z C 1	7900085	44
IM 12 - 04N A O - Z U 0	7902121	84	IM 18 - 08B P S - Z W 1	7900081	44
IM 12 - 04N A S - Z U 0	7902120	84	IM 18 - 08N C P - Z C 1	7902938	48
IM 12 - 04N C P - Z C 1	7902930	38	IM 18 - 08N C P - Z W 1	7902937	48
IM 12 - 04N C P - Z W 1	7902929	38	IM 18 - 08N D S - Z C 1	6020324	80
IM 12 - 04N D S - Z C 1	6020316	78	IM 18 - 08N D S - Z W 1	6020322	80
IM 12 - 04N D S - Z W 1	6020314	78	IM 18 - 08N N O - Z W 1	6011998	40
IM 12 - 04N N O - Z W 1	6011978	30	IM 18 - 08N N P - Z C 1	7902934	46
IM 12 - 04N N P - Z C 1	7902926	36	IM 18 - 08N N S - Z C 1	6012000	40
IM 12 - 04N N S - Z C 1	6011984	30	IM 18 - 08N N S - Z C K	1017445	42
IM 12 - 04N N S - Z C K	1017441	32	IM 18 - 08N N S - Z U K	1017443	42
IM 12 - 04N N S - Z T 1	6011980	30	IM 18 - 08N N S - Z W 1	6011996	40
IM 12 - 04N N S - Z U K	1017439	32	IM 18 - 08N - N - Z W 0	6021127	102
IM 12 - 04N N S - Z W 1	6011976	30	IM 18 - 08N P O - Z C 1	6012001	40
IM 12 - 04N - N - Z W 0	6021125	100	IM 18 - 08N P P - Z C 1	7902933	46
IM 12 - 04N P O - Z C 1	6011985	30	IM 18 - 08N P S - Z C 1	6011999	40
IM 12 - 04N P O - Z W 1	6011977	30	IM 18 - 08N P S - Z C K	1017433	42
IM 12 - 04N P P - Z C 1	7902925	36	IM 18 - 08N P S - Z U K	1017431	42
IM 12 - 04N P S - Z C 1	6011983	30	IM 18 - 08N P S - Z W 1	6011995	40
IM 12 - 04N P S - Z C K	1017429	32	IM 18 - 08N U O - Z U 0	7902125	86
IM 12 - 04N P S - Z T 1	6011979	30	IM 18 - 08N U S - Z U 0	7902124	86
IM 12 - 04N P S - Z U K	1017427	32	IM 18 - 12N N S - Z C 1	7900098	44
IM 12 - 04N P S - Z W 1	6011975	30	IM 18 - 12N N S - Z W 1	7900094	44
IM 18 - 05B C P - Z C 1	7902936	48	IM 18 - 12N P O - Z C 1	7900099	44
IM 18 - 05B C P - Z W 1	7902935	48	IM 18 - 12N P O - Z W 1	7900095	44
IM 18 - 05B D S - Z C 1	6020320	80	IM 18 - 12N P S - Z C 1	7900097	44
IM 18 - 05B D S - Z W 1	6020318	80	IM 18 - 12N P S - Z W 1	7900093	44
IM 18 - 05B N P - Z C 1	7902932	46	IM 30 - 10B D S - Z C 1	6020328	82
IM 18 - 05B N S - Z C 1	6011992	40	IM 30 - 10B D S - Z W 1	6020326	82
IM 18 - 05B N S - Z C K	1017444	42	IM 30 - 10B N S - Z C 1	6020279	50
IM 18 - 05B N S - Z U K	1017442	42	IM 30 - 10B N S - Z C K	1017448	52

Index

Type designation

Type designation	Order No.	Page	Type designation	Order No.	Page
IM 30 - 10B N S - Z U K	1017446	52	IQ 10 - 03B N S - K U 0	7900204	68
IM 30 - 10B N S - Z W 1	6020275	50	IQ 10 - 03B P S - K T 0	7900205	68
IM 30 - 10B - N - Z W 0	6021128	104	IQ 10 - 03B P S - K U 0	7900203	68
IM 30 - 10B P O - Z C 1	6020280	50	IQ 10 - 06N N S - K T 0	7900210	68
IM 30 - 10B P S - Z C 1	6020278	50	IQ 10 - 06N N S - K U 0	7900208	68
IM 30 - 10B P S - Z C K	1017436	52	IQ 10 - 06N P S - K T 0	7900209	68
IM 30 - 10B P S - Z U K	1017434	52	IQ 10 - 06N P S - K U 0	7900207	68
IM 30 - 10B P S - Z W 1	6020274	50	IQ 12 - 03B N S - K T 0	1016461	70
IM 30 - 10B U O - Z U 0	7902127	88	IQ 12 - 03B N S - K U 0	1016299	70
IM 30 - 10B U S - Z U 0	7902126	88	IQ 12 - 03B P S - K T 0	1016276	70
IM 30 - 15B N S - Z C 1	7900146	54	IQ 12 - 03B P S - K U 0	1016275	70
IM 30 - 15B N S - Z W 1	7900142	54	IQ 12 - 06N P S - K T 0	1016467	70
IM 30 - 15B P O - Z C 1	7900147	54	IQ 12 - 06N P S - K U 0	1016463	70
IM 30 - 15B P O - Z W 1	7900143	54	IQ 40 - 15B P P - K K 0	7900219	72
IM 30 - 15B P S - Z C 1	7900145	54	IQ 40 - 15B P S - K C 0	7900223	74
IM 30 - 15B P S - Z W 1	7900141	54	IQ 40 - 15B U P - K K 0	7902136	94
IM 30 - 15N D S - Z C 1	6020332	82	IQ 40 - 20B P P - K C K	6012014	74
IM 30 - 15N D S - Z W 1	6020330	82	IQ 40 - 20N P P - K K 0	7900221	72
IM 30 - 15N N S - Z C 1	6020287	50	IQ 40 - 20N U P - K K 0	7902137	94
IM 30 - 15N N S - Z C K	1017449	52	IQ 40 - 35N P P - K C K	6012015	74
IM 30 - 15N N S - Z U K	1017447	52	IQ 40 - 35N P S - K C 0	7900224	74
IM 30 - 15N N S - Z W 1	6020283	50	IQ 80 - 60N P P - K K 0	7900227	76
IM 30 - 15N - N - Z W 0	6021129	104	IQ 80 - 60N U P - K K 0	7902138	96
IM 30 - 15N P O - Z W 1	6020284	50	MM08 - 60A P S - Z T 0	7900266	120
IM 30 - 15N P S - Z C 1	6020286	50	MM08 - 60A P S - Z U 0	7900264	120
IM 30 - 15N P S - Z C K	1017437	52	MM12 - 60A - N - Z C 0	7900287	128
IM 30 - 15N P S - Z U K	1017435	52	MM12 - 60A - N - Z W 0	7900286	128
IM 30 - 15N P S - Z W 1	6020282	50	MM12 - 60A P S - Z C 0	7900270	122
IM 30 - 15N U O - Z U 0	7902129	88	MM12 - 60A P S - Z U 0	7900268	122
IM 30 - 15N U S - Z U 0	7902128	88	MM18 - 70A - N - Z C 0	7900289	130
IM 30 - 20N N S - Z C 1	7900158	54	MM18 - 70A - N - Z W 0	7900288	130
IM 30 - 20N N S - Z W 1	7900154	54	MM18 - 70A P S - Z C 0	7900274	124
IM 30 - 20N P O - Z C 1	7900159	54	MM18 - 70A P S - Z U 0	7900272	124
IM 30 - 20N P O - Z W 1	7900155	54	MQ 10 - 60A N S - K T 0	7900281	126
IM 30 - 20N P S - Z C 1	7900157	54	MQ 10 - 60A N S - K U 0	7900279	126
IM 30 - 20N P S - Z W 1	7900153	54	MQ 10 - 60A P S - K T 0	7900280	126
IQ 05 - 0B8 N S - Z U 1	6020162	64	MQ 10 - 60A P S - K U 0	7900278	126
IQ 05 - 0B8 P S - Z U 1	6020161	64	MZ F1 - 03V P S - K P 0	7900597	152
IQ 08 - 02B N S - K T 0	7900198	66	MZ F1 - 03V P S - K U 0	7900596	152
IQ 08 - 02B N S - K U 0	7900196	66	MZ F1 - 03V P S - K U B	7903147	152
IQ 08 - 02B P S - K T 0	7900197	66	MZ K1 - 02V P S - A T 0	7900604	148
IQ 08 - 02B P S - K U 0	7900195	66	MZ K1 - 02V P S - A U 0	7900602	148
IQ 08 - 04N P S - K T 0	7900201	66	MZ K3 - 02V P S - A T 0	7901952	150
IQ 08 - 04N P S - K U 0	7900199	66	MZ P3 - 03V - N - A C 0	7901441	164
IQ 10 - 03B N S - K T 0	7900206	68	MZ P3 - 03V - N - A W 0	7901440	164
			MZ P3 - 03V P S - A C 0	7900612	144

Index

Type designation

Type designation	Order No.	Page	Type designation	Order No.	Page
MZ P3 - 03V P S - A U 0	7900610	144			
MZ P4 - 03V - N - A C 0	7901330	166			
MZ P4 - 03V - N - A W 0	7901329	166			
MZ P4 - 03V P S - A C 0	7900616	146			
MZ P4 - 03V P S - A U 0	7900614	146			
MZ R1 - 03V N S - A U 0	7900593	136			
MZ R1 - 03V P S - A T 0	7900594	136			
MZ R1 - 03V P S - A U 0	7900592	136			
MZ R2 - 03V - N - A W 0	7901321	160			
MZ R2 - 03V P S - A T 0	7900600	138			
MZ R2 - 03V P S - A U 0	7900598	138			
MZ T1 - 03V P S - K P 0	1016910	154			
MZ T1 - 03V P S - K W 0	1016809	154			
MZ U2 - 03V P S - D C M	1017450	158			
MZ U2 - 03V P S - T C M	1017451	158			
MZ Z1 - 03V - N - A C 0	7901324	162			
MZ Z1 - 03V - N - A W 0	7901323	162			
MZ Z1 - 03V N S - A C 0	7900609	140			
MZ Z1 - 03V P S - A C 0	7900608	140			
MZ Z1 - 03V P S - A U 0	7900606	140			
MZ Z2 - 03V P S - K C 0	7900624	142			
MZ Z2 - 03V P S - K U 0	7900622	142			
MZ Z2 - 03Z N S - K U 0	7900619	142			
MZ Z2 - 03Z P S - K C 0	7900620	142			
MZ Z2 - 03Z P S - K U 0	7900618	142			
RZ F1 - 03Z U S - K P 0	7903376	152			
RZ F1 - 03Z U S - K W 0	7903466	152			
RZ R1 - 03Z U S - A T 0	7901265	136			
RZ R1 - 03Z U S - A W 0	7901264	136			
RZ T1 - 03Z R S - K P 0	1016912	156			
RZ T1 - 03Z R S - K W 0	1016911	156			

Index

Order numbers

Order No.	Type designation	Page	Order No.	Type designation	Page
1016275	IQ 12 - 03B P S - K U O	70	6011974	IM12 - 02B N O - Z C 1	30
1016276	IQ 12 - 03B P S - K T O	70	6011975	IM12 - 04N P S - Z W1	30
1016299	IQ 12 - 03B N S - K U O	70	6011976	IM12 - 04N N S - Z W1	30
1016461	IQ 12 - 03B N S - K T O	70	6011977	IM12 - 04N P O - Z W1	30
1016463	IQ 12 - 06N P S - K U O	70	6011978	IM12 - 04N N O - Z W1	30
1016467	IQ 12 - 06N P S - K T O	70	6011979	IM12 - 04N P S - Z T 1	30
1016809	MZT1 - 03V P S - K W O	154	6011980	IM12 - 04N N S - Z T 1	30
1016910	MZT1 - 03V P S - K P O	154	6011983	IM12 - 04N P S - Z C 1	30
1016911	RZT1 - 03Z R S - K W O	156	6011984	IM12 - 04N N S - Z C 1	30
1016912	RZT1 - 03Z R S - K P O	156	6011985	IM12 - 04N P O - Z C 1	30
1017426	IM12 - 02B P S - Z U K	32	6011987	IM18 - 05B P S - Z W1	40
1017427	IM12 - 04N P S - Z U K	32	6011988	IM18 - 05B N S - Z W1	40
1017428	IM12 - 02B P S - Z C K	32	6011989	IM18 - 05B P O - Z W1	40
1017429	IM12 - 04N P S - Z C K	32	6011991	IM18 - 05B P S - Z C 1	40
1017430	IM18 - 05B P S - Z U K	42	6011992	IM18 - 05B N S - Z C 1	40
1017431	IM18 - 08N P S - Z U K	42	6011993	IM18 - 05B P O - Z C 1	40
1017432	IM18 - 05B P S - Z C K	42	6011995	IM18 - 08N P S - Z W1	40
1017433	IM18 - 08N P S - Z C K	42	6011996	IM18 - 08N N S - Z W1	40
1017434	IM30 - 10B P S - Z U K	52	6011998	IM18 - 08N N O - Z W1	40
1017435	IM30 - 15N P S - Z U K	52	6011999	IM18 - 08N P S - Z C 1	40
1017436	IM30 - 10B P S - Z C K	52	6012000	IM18 - 08N N S - Z C 1	40
1017437	IM30 - 15N P S - Z C K	52	6012001	IM18 - 08N P O - Z C 1	40
1017438	IM12 - 02B N S - Z U K	32	6012014	IQ40 - 20B P P - K C K	74
1017439	IM12 - 04N N S - Z U K	32	6012015	IQ40 - 35N P P - K C K	74
1017440	IM12 - 02B N S - Z C K	32	6020110	IM05 - 0B8 P S - Z T 1	22
1017441	IM12 - 04N N S - Z C K	32	6020111	IM08 - 1B5 P S - Z W K	26
1017442	IM18 - 05B N S - Z U K	42	6020112	IM08 - 1B5 P S - Z T K	26
1017443	IM18 - 08N N S - Z U K	42	6020113	IH04 - 0B8 P S - V W1	58
1017444	IM18 - 05B N S - Z C K	42	6020114	IH04 - 0B8 P S - V T 1	58
1017445	IM18 - 08N N S - Z C K	42	6020136	CM18 - 08B P P - K W1	108
1017446	IM30 - 10B N S - Z U K	52	6020141	IH03 - 0B6 P S - V U 1	56
1017447	IM30 - 15N N S - Z U K	52	6020142	IH03 - 0B6 N S - V U 1	56
1017448	IM30 - 10B N S - Z C K	52	6020145	IM04 - 0B6 P S - Z U 1	20
1017449	IM30 - 15N N S - Z C K	52	6020146	IM04 - 0B6 N S - Z U 1	20
1017450	MZU2 - 03V P S - D C M	158	6020149	IH04 - 0B8 N S - V W1	58
1017451	MZU2 - 03V P S - T C M	158	6020152	IH04 - 0B8 N S - V T 1	58
6011591	IM05 - 0B8 P S - Z W1	22	6020155	IM05 - 0B8 N S - Z W1	22
6011963	IM12 - 02B P S - Z W1	30	6020158	IM05 - 0B8 N S - Z T 1	22
6011964	IM12 - 02B N S - Z W1	30	6020161	IQ05 - 0B8 P S - Z U 1	64
6011965	IM12 - 02B P O - Z W1	30	6020162	IQ05 - 0B8 N S - Z U 1	64
6011966	IM12 - 02B N O - Z W1	30	6020165	IH06 - 1B5 P S - V W K	60
6011967	IM12 - 02B P S - Z T 1	30	6020166	IH06 - 1B5 N S - V W K	60
6011968	IM12 - 02B N S - Z T 1	30	6020169	IH06 - 1B5 P S - V T K	60
6011971	IM12 - 02B P S - Z C 1	30	6020170	IH06 - 1B5 N S - V T K	60
6011972	IM12 - 02B N S - Z C 1	30	6020173	IM08 - 1B5 N S - Z W K	26
6011973	IM12 - 02B P O - Z C 1	30	6020176	IM08 - 1B5 N S - Z T K	26

Index

Order numbers

Order No.	Type designation	Page	Order No.	Type designation	Page
6020215	IM08 - 1B5 P S - Z W1	24	6021124	IM12 - 02B - N - Z W0	100
6020216	IM08 - 1B5 N S - Z W1	24	6021125	IM12 - 04N - N - Z W0	100
6020217	IM08 - 1B5 P O - Z W1	24	6021126	IM18 - 05B - N - Z W0	102
6020218	IM08 - 1B5 N O - Z W1	24	6021127	IM18 - 08N - N - Z W0	102
6020219	IM08 - 1B5 P S - Z T 1	24	6021128	IM30 - 10B - N - Z W0	104
6020220	IM08 - 1B5 N S - Z T 1	24	6021129	IM30 - 15N - N - Z W0	104
6020221	IM08 - 1B5 P O - Z T 1	24	7900001	IM08 - 02B P S - Z W1	28
6020223	IM08 - 1B5 P S - Z C 1	24	7900002	IM08 - 02B N S - Z W1	28
6020224	IM08 - 1B5 N S - Z C 1	24	7900003	IM08 - 02B P O - Z W1	28
6020227	IM08 - 2N5 P S - Z W1	24	7900005	IM08 - 02B P S - Z T 1	28
6020228	IM08 - 2N5 N S - Z W1	24	7900006	IM08 - 02B N S - Z T 1	28
6020231	IM08 - 2N5 P S - Z T 1	24	7900007	IM08 - 02B P O - Z T 1	28
6020232	IM08 - 2N5 N S - Z T 1	24	7900008	IM08 - 02B N O - Z T 1	28
6020235	IM08 - 2N5 P S - Z C 1	24	7900009	IM08 - 04N P S - Z W1	28
6020236	IM08 - 2N5 N S - Z C 1	24	7900010	IM08 - 04N N S - Z W1	28
6020274	IM30 - 10B P S - Z W1	50	7900011	IM08 - 04N P O - Z W1	28
6020275	IM30 - 10B N S - Z W1	50	7900013	IM08 - 04N P S - Z T 1	28
6020278	IM30 - 10B P S - Z C 1	50	7900014	IM08 - 04N N S - Z T 1	28
6020279	IM30 - 10B N S - Z C 1	50	7900015	IM08 - 04N P O - Z T 1	28
6020280	IM30 - 10B P O - Z C 1	50	7900016	IM08 - 04N N O - Z T 1	28
6020282	IM30 - 15N P S - Z W1	50	7900033	IM12 - 04B P S - Z W1	34
6020283	IM30 - 15N N S - Z W1	50	7900034	IM12 - 04B N S - Z W1	34
6020284	IM30 - 15N P O - Z W1	50	7900035	IM12 - 04B P O - Z W1	34
6020286	IM30 - 15N P S - Z C 1	50	7900037	IM12 - 04B P S - Z C 1	34
6020287	IM30 - 15N N S - Z C 1	50	7900038	IM12 - 04B N S - Z C 1	34
6020310	IM12 - 02B D S - Z W1	78	7900039	IM12 - 04B P O - Z C 1	34
6020312	IM12 - 02B D S - Z C 1	78	7900041	IM12 - 08N P S - Z W1	34
6020314	IM12 - 04N D S - Z W1	78	7900042	IM12 - 08N N S - Z W1	34
6020316	IM12 - 04N D S - Z C 1	78	7900043	IM12 - 08N P O - Z W1	34
6020318	IM18 - 05B D S - Z W1	80	7900044	IM12 - 08N N O - Z W1	34
6020320	IM18 - 05B D S - Z C 1	80	7900045	IM12 - 08N P S - Z C 1	34
6020322	IM18 - 08N D S - Z W1	80	7900046	IM12 - 08N N S - Z C 1	34
6020324	IM18 - 08N D S - Z C 1	80	7900047	IM12 - 08N P O - Z C 1	34
6020326	IM30 - 10B D S - Z W1	82	7900081	IM18 - 08B P S - Z W1	44
6020328	IM30 - 10B D S - Z C 1	82	7900082	IM18 - 08B N S - Z W1	44
6020330	IM30 - 15N D S - Z W1	82	7900083	IM18 - 08B P O - Z W1	44
6020332	IM30 - 15N D S - Z C 1	82	7900085	IM18 - 08B P S - Z C 1	44
6020388	CM18 - 08B P P - K C 1	108	7900086	IM18 - 08B N S - Z C 1	44
6020389	CM18 - 12N P P - K W1	108	7900087	IM18 - 08B P O - Z C 1	44
6020410	CM18 - 12N P P - K C 1	108	7900093	IM18 - 12N P S - Z W1	44
6020473	CM30 - 16B P P - K W1	110	7900094	IM18 - 12N N S - Z W1	44
6020475	CM30 - 16B P P - K C 1	110	7900095	IM18 - 12N P O - Z W1	44
6020476	CM30 - 25N P P - K W1	110	7900097	IM18 - 12N P S - Z C 1	44
6020477	CM30 - 25N P P - K C 1	110	7900098	IM18 - 12N N S - Z C 1	44
6020478	CQ35 - 25N P P - K W1	112	7900099	IM18 - 12N P O - Z C 1	44
6020479	CQ35 - 25N P P - K C 1	112	7900141	IM30 - 15B P S - Z W1	54
6021123	IM08 - 01B - N - Z W0	98	7900142	IM30 - 15B N S - Z W1	54

Index

Order numbers

Order No.	Type designation	Page	Order No.	Type designation	Page
7900143	IM30 - 15B P O - Z W1	54	7900281	MQ10 - 60A NS - K T O	126
7900145	IM30 - 15B P S - Z C 1	54	7900286	MM12 - 60A - N - Z W0	128
7900146	IM30 - 15B NS - Z C 1	54	7900287	MM12 - 60A - N - Z C 0	128
7900147	IM30 - 15B P O - Z C 1	54	7900288	MM18 - 70A - N - Z W0	130
7900153	IM30 - 20N P S - Z W1	54	7900289	MM18 - 70A - N - Z C 0	130
7900154	IM30 - 20N NS - Z W1	54	7900592	MZR1 - 03V P S - A U 0	136
7900155	IM30 - 20N P O - Z W1	54	7900593	MZR1 - 03V NS - A U 0	136
7900157	IM30 - 20N P S - Z C 1	54	7900594	MZR1 - 03V P S - A T 0	136
7900158	IM30 - 20N NS - Z C 1	54	7900596	MZF1 - 03V P S - K U 0	152
7900159	IM30 - 20N P O - Z C 1	54	7900597	MZF1 - 03V P S - K P 0	152
7900177	IH06 - 02B P S - V W1	62	7900598	MZR2 - 03V P S - A U 0	138
7900178	IH06 - 02B NS - V W1	62	7900600	MZR2 - 03V P S - A T 0	138
7900179	IH06 - 02B P S - V T 1	62	7900602	MZK1 - 02V P S - A U 0	148
7900180	IH06 - 02B NS - V T 1	62	7900604	MZK1 - 02V P S - A T 0	148
7900181	IH06 - 04N P S - V W1	62	7900606	MZZ1 - 03V P S - A U 0	140
7900182	IH06 - 04N NS - V W1	62	7900608	MZZ1 - 03V P S - A C 0	140
7900183	IH06 - 04N P S - V T 1	62	7900609	MZZ1 - 03V NS - A C 0	140
7900184	IH06 - 04N NS - V T 1	62	7900610	MZP3 - 03V P S - A U 0	144
7900195	IQ08 - 02B P S - K U 0	66	7900612	MZP3 - 03V P S - A C 0	144
7900196	IQ08 - 02B NS - K U 0	66	7900614	MZP4 - 03V P S - A U 0	146
7900197	IQ08 - 02B P S - K T 0	66	7900616	MZP4 - 03V P S - A C 0	146
7900198	IQ08 - 02B NS - K T 0	66	7900618	MZZ2 - 03Z P S - K U 0	142
7900199	IQ08 - 04N P S - K U 0	66	7900619	MZZ2 - 03Z NS - K U 0	142
7900201	IQ08 - 04N P S - K T 0	66	7900620	MZZ2 - 03Z P S - K C 0	142
7900203	IQ10 - 03B P S - K U 0	68	7900622	MZZ2 - 03V P S - K U 0	142
7900204	IQ10 - 03B NS - K U 0	68	7900624	MZZ2 - 03V P S - K C 0	142
7900205	IQ10 - 03B P S - K T 0	68	7901264	RZR1 - 03Z US - A W0	136
7900206	IQ10 - 03B NS - K T 0	68	7901265	RZR1 - 03Z US - A T 0	136
7900207	IQ10 - 06N P S - K U 0	68	7901321	MZR2 - 03V - N - A W0	160
7900208	IQ10 - 06N NS - K U 0	68	7901323	MZZ1 - 03V - N - A W0	162
7900209	IQ10 - 06N P S - K T 0	68	7901324	MZZ1 - 03V - N - A C 0	162
7900210	IQ10 - 06N NS - K T 0	68	7901329	MZP4 - 03V - N - A W0	166
7900219	IQ40 - 15B P P - K K 0	72	7901330	MZP4 - 03V - N - A C 0	166
7900221	IQ40 - 20N P P - K K 0	72	7901440	MZP3 - 03V - N - A W0	164
7900223	IQ40 - 15B P S - K C 0	74	7901441	MZP3 - 03V - N - A C 0	164
7900224	IQ40 - 35N P S - K C 0	74	7901952	MZK3 - 02V P S - A T 0	150
7900227	IQ80 - 60N P P - K K 0	76	7902118	IM12 - 02B A S - Z U 0	84
7900264	MM08 - 60A P S - Z U 0	120	7902119	IM12 - 02B A O - Z U 0	84
7900266	MM08 - 60A P S - Z T 0	120	7902120	IM12 - 04N A S - Z U 0	84
7900268	MM12 - 60A P S - Z U 0	122	7902121	IM12 - 04N A O - Z U 0	84
7900270	MM12 - 60A P S - Z C 0	122	7902122	IM18 - 05B US - Z U 0	86
7900272	MM18 - 70A P S - Z U 0	124	7902123	IM18 - 05B U O - Z U 0	86
7900274	MM18 - 70A P S - Z C 0	124	7902124	IM18 - 08N US - Z U 0	86
7900278	MQ10 - 60A P S - K U 0	126	7902125	IM18 - 08N U O - Z U 0	86
7900279	MQ10 - 60A NS - K U 0	126	7902126	IM30 - 10B US - Z U 0	88
7900280	MQ10 - 60A P S - K T 0	126	7902127	IM30 - 10B U O - Z U 0	88

<u>Order No.</u>	<u>Type designation</u>	<u>Page</u>
7902128	IM30 - 15N U S - Z U 0	88
7902129	IM30 - 15N U O - Z U 0	88
7902130	IH20 - 10N U S - K U 0	90
7902131	IH20 - 10N U O - K U 0	90
7902134	IH34 - 30N U S - K U 0	92
7902135	IH34 - 30N U O - K U 0	92
7902136	IQ40 - 15B U P - K K 0	94
7902137	IQ40 - 20N U P - K K 0	94
7902138	IQ80 - 60N U P - K K 0	96
7902923	IM12 - 02B P P - Z C 1	36
7902924	IM12 - 02B N P - Z C 1	36
7902925	IM12 - 04N P P - Z C 1	36
7902926	IM12 - 04N N P - Z C 1	36
7902927	IM12 - 02B C P - Z W 1	38
7902928	IM12 - 02B C P - Z C 1	38
7902929	IM12 - 04N C P - Z W 1	38
7902930	IM12 - 04N C P - Z C 1	38
7902931	IM18 - 05B P P - Z C 1	46
7902932	IM18 - 05B N P - Z C 1	46
7902933	IM18 - 08N P P - Z C 1	46
7902934	IM18 - 08N N P - Z C 1	46
7902935	IM18 - 05B C P - Z W 1	48
7902936	IM18 - 05B C P - Z C 1	48
7902937	IM18 - 08N C P - Z W 1	48
7902938	IM18 - 08N C P - Z C 1	48
7903147	MZF1 - 03V P S - K U B	152
7903376	RZF1 - 03Z U S - K P 0	152
7903466	RZF1 - 03Z U S - K W 0	152

<u>Order No.</u>	<u>Type designation</u>	<u>Page</u>
------------------	-------------------------	-------------

SICK Industrial sensor systems

Divisions

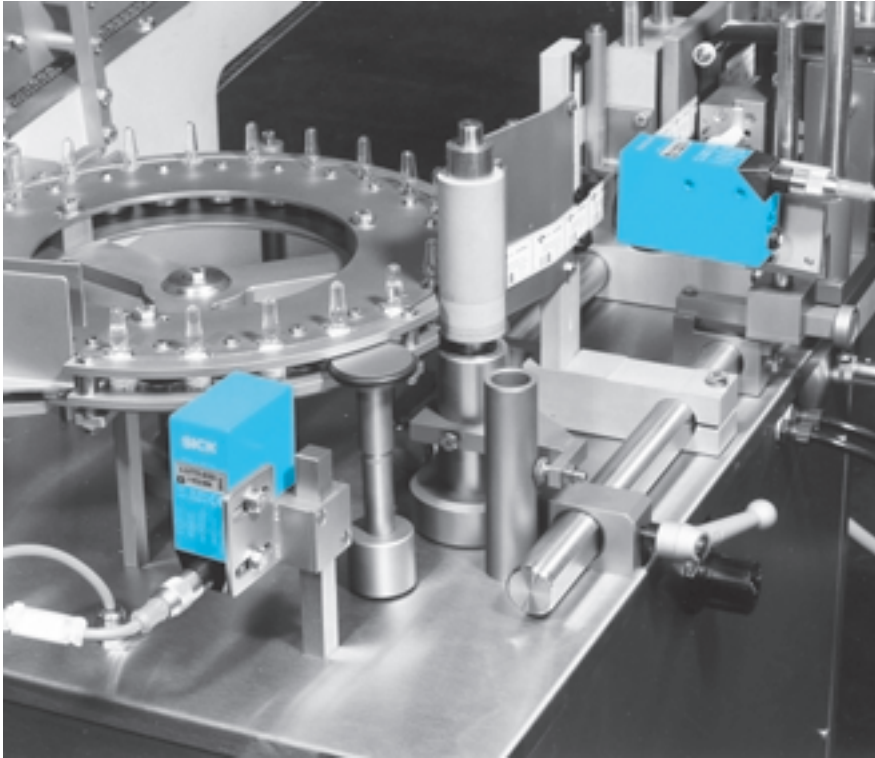

Industrial sensors:

The current range of optical and inductive sensors reflects the experience of more than 50 years of partnership with virtually every sector of industrial automation.

The tasks: recording, counting, classifying and positioning objects, detecting shape and position, colour and surface differences, even under extreme surrounding conditions. SICK sensors optimise production and logistics processes and therefore contribute to improving product quality.

Products:

Photoelectric switches and photoelectric proximity switches, distance sensors, complex sensors, reflex light grids, multi-dimensional sensors, inductive proximity sensors, capacitive proximity sensors, magnetic proximity sensors, magnetic cylinder sensors.



Safety systems

In automated production and logistics processes, safety light curtains, light grids, laser scanners and interlocks assure effective accident prevention and personal protection. Through long years of experience in innumerable industrial applications, pioneering safety products have been developed which have set new standards in many fields. Thanks to its comprehensive expertise in designing, manufacturing and operating safety equipment, SICK has become the leader in its industry.

Products:

Guarding surfaces, danger points, danger zones, preventing access, safety interlocks, software for CE conformity assessment of plant and machinery.



Environmental monitoring

In power stations and industrial plants, SICK systems monitor compliance with statutory limit values for toxic emissions, thereby supporting process operation and improvement. SICK is the only manufacturer to offer a complete program of units for *in situ* and extractive measurement processes. Pioneering SICK systems, e.g. fog-measuring units and sensors for controlling tunnel-ventilation equipment, are also responsible for keeping traffic flowing freely on the roads.

Products:

Dust measurement, gas velocity measuring systems, analysers and analysis systems for process and emission monitoring, tunnel-sensor systems.



Auto Ident

SICK barcode scanners are in demand wherever products and goods have to be identified quickly, safely and reliably. SICK laser scanners have also become indispensable in applications involving the classification and positioning of products or automatic flow control. They reliably record shape, position and contour.

They also monitor access roads, multi-storey car parks, subway stations, level crossings and locks, i.e. wherever the safe and smooth flow of traffic is essential.

Products:

Stationary barcode readers, data-transmitting photoelectric switches, laser measuring systems for indoor and outdoor applications, hand-held barcode reading systems for mobile and stationary use.