

Vision Sensors

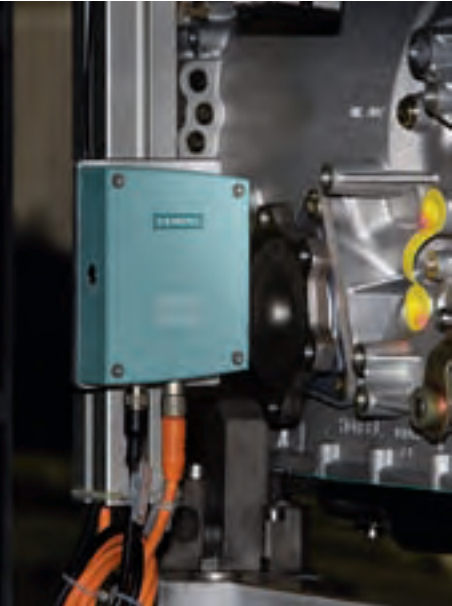

3/2	Introduction
3/4	SIMATIC MV220
3/7	SIMATIC MV230
3/10	SIMATIC VS120
3/13	Lenses

Vision Sensors

Introduction

Vision sensors – Simple and intelligent

SIMATIC MV220 color mark sensor

The SIMATIC MV220 compact color mark sensor is a complete image processing system for automatic inspection of colored objects. It is ideally suited for use under harsh industrial conditions due to its degree of protection IP65.

It is used for applications in manufacturing, the packaging industry and food and beverages industry. It is so easy to operate that no courses are necessary and the system is "trained" instead of programmed, so even non-experts can use it instantly. It is integrated in the plant automation using digital inputs and outputs.

SIMATIC MV230 surface profile sensor

The SIMATIC MV230 compact surface profile sensor is a complete image processing system for the automatic inspection of objects based on their surface contour or profile. It is ideally suited for use under harsh industrial conditions due to its degree of protection IP65.

The application areas lie in production engineering, machine construction and the packaging industry. It is so easy to operate that no courses are necessary and the system is "trained" instead of programmed, so even non-experts can use it instantly. It is integrated in the plant automation using digital inputs and outputs.

SIMATIC VS120 Vision Sensors

For inspection of small components for shape, type or position, our intelligent VS120 vision sensors are the perfect choice. The complete package comprises lighting, evaluation unit, sensor and cables. They are installed and commissioned with a flick of the wrist. It is so easy to operate that no courses are necessary and the system is "trained" instead of programmed, so even non-experts can use it instantly.

The compact design allows it to be used in a wide range of different infeed systems such as vibrating conveyors, conveyor belts or grippers. Thanks to standardized interfaces, the vision sensors can be flexibly integrated into the plant automation. For simple conveyor units, a stand-alone solution is available without an additional PLC.

Highlights

SIMATIC MV220 color mark sensor

- Eminently suitable for use in harsh industrial environments thanks to degree of protection IP65
- Control of extremely high-speed processes possible thanks to the short inspection time of the sensor (approximately 30 inspections per second)
- Short changeover times thanks to simple model change
 - 16 inspection models can be taught
 - Inspection models are selected using digital inputs
- Flexible adaptation to the individual applications possible
 - Flexible adjustment of image window and operating distance
 - Flexible adjustment of parameters
- Fast commissioning
 - No image processing knowledge necessary
 - No programming necessary

Highlights

SIMATIC MV230 surface profile sensor

- Eminently suitable for use in harsh industrial environments thanks to degree of protection IP65
- Shielding against ambient light is not usually necessary due to its high degree of immunity to ambient light
- Short changeover times thanks to simple model change
 - 16 inspection models can be taught
 - Inspection models are selected using digital inputs
- Flexible adaptation to the individual applications possible
 - Flexible adjustment of the laser line range that can be evaluated
 - Flexible adjustment of parameters
- Fast commissioning
 - No image processing knowledge necessary
 - No programming necessary
- Effective start-up and maintenance functions using diagnostics, checksums and statistical information
- Prevention of unauthorized operation through button disabling

Highlights

SIMATIC VS120 Vision Sensors

- Simple configuration by presenting the "good" object to be detected.
- The "teach-in" is performed automatically when the training function of the device is activated.
- Parameters are assigned by means of a web-based user interface that is executable on different platforms to which the following requirements apply: Browser (IE5.5 and higher) or JAVA-VM (MS, SUN).
- The web-based user interface can also be used to control the device from an HMI device. The requirements regarding the browser and JAVA VM also apply here.
- Remote maintenance concept by means of web-based user interface.
- Remote control via integrated digital inputs, PROFIBUS or PROFINET IO.
- Supplied as a complete package in several variants for different object sizes

Application

Fields of application for the vision sensors

Object inspection with SIMATIC MV220	
Inspection task	Color inspection tasks in manufacturing and assembly systems
Applications	Manufacturing, packaging industry and food and beverages industry
Type of parts to be inspected	e.g. completeness of colored parts, blister packs, cups, bottles, labels and covers
Object inspection with SIMATIC MV230	
Inspection task	Inspection of surface contours and profiles in production engineering and assembly
Applications	Production engineering, the packaging industry and machine construction
Type of parts to be inspected	Inspection, parts recognition and position checking of parts based on their geometric surface contour or profile
Object inspection with SIMATIC VS120	
Inspection task	Correctness, lack of damage and position of a part or pattern; position of the part with x/y coordinate and angle of rotation in degrees
Applications	Conveyor belts, workholder carousels, gripper units, production machines
Type of parts to be inspected	e.g. screws, bolts, molded parts, pharmaceutical products, confectionery, logos, patterns ...

Technical specifications

Type	MV220	MV230	VS120
Main task	Object inspection (color)	Object inspection	Object inspection
Sensor type	CMOS sensor (color), 640 x 480 pixels	CMOS sensor, 750 x 480 pixels	CCD chip, 640 x 480 quadratic pixels
Image capture	Digital, max. 33 frames/second	Digital, 20 frames/second	Triggered frame transfer
Sensor head type	Variable display field size	Fixed display field size	2 x fixed focus with fixed display field size, 1 x C/CS-Mount with variable display field size
<ul style="list-style-type: none"> • Available versions • Enclosure • Degree of protection 	Complete system see below IP65	see below IP65	Extruded aluminum enclosure IP65
Parts size (W x H)	Display field size (infinitely) adjustable <ul style="list-style-type: none"> • For object distance of 50 mm: Display field size 40 x 30 mm • For object distance of 250 mm: Display field size 200 x 150 mm 	<ul style="list-style-type: none"> • For object distance of 310 mm: Display field size 75 x 100 mm 	<ul style="list-style-type: none"> • Objects up to 60 x 40 mm, inspection window: 70 x 50 mm • Objects up to 34 x 24 mm, inspection window: 40 x 30 mm • Variable size of object with C/CS-Mount
Ambient temperature	0 ... 45 °C, no condensation	0 ... 45 °C, no condensation	0 ... 50 °C, without fans
Lighting			
<ul style="list-style-type: none"> • Illuminant • Enclosure 	Integrated white LEDs see below	Laser diode, red light see below	Red LEDs Plastic ring light with plastic diffusing panel IP65
<ul style="list-style-type: none"> • Degree of protection 	IP65	IP65	IP65
Evaluation unit			
<ul style="list-style-type: none"> • Operator controls 	4-character text display with 4 operator buttons	4-character text display with 4 operator buttons	LCD display panel (4 lines with 10 characters each) and 6 operator buttons for menu operation
<ul style="list-style-type: none"> • Number of types to be saved • Triggering inspection 	up to 16 External	up to 16 External or internal freewheeling trigger	up to 64 External
<ul style="list-style-type: none"> • Permissible parts rate 	33 inspections/s	20 inspections/s	20 items/s (object-dependent)
Infeed direction			
<ul style="list-style-type: none"> - For external triggering - For automatic triggering 	Any -	Any Any	Any -
Enclosure (degree of protection)	Plastic, aluminum (IP65)	Plastic, aluminum (IP65)	Plastic, suitable for cabinetless installation (IP40)
Interfaces on evaluation unit			
<ul style="list-style-type: none"> • Digital inputs for 24 V DC • Digital outputs for 24 V DC • Integrated interface • Sensor head interface • Supply voltage 	6 (including 1 trigger input) 5 - - 24 V DC	6 (including 1 trigger input) 4 - - 24 V DC	8 (including 1 trigger input) 6 PROFIBUS DP/Ethernet/PROFINET IO Digital interface 24 V DC
Current consumption, max.	2 A	2 A	4 A

Vision Sensors

SIMATIC MV220

Overview



- Compact image processing sensor for automatic inspection of colored objects
- A synthesis of high-performance image processing technology with simple, compact sensors
- For applications in manufacturing, the packaging industry and food and beverages industry
- Process-oriented implementation thanks to degree of protection IP65
- Integration in plant automation using digital inputs and outputs
- Quick familiarization with task thanks to the teach-in function

Benefits

- Eminently suitable for use in harsh industrial environments thanks to degree of protection IP65
- Control of extremely high-speed processes possible thanks to the short inspection time of the sensor (approximately 30 inspections per second)
- Short changeover times thanks to simple model change
 - 16 inspection models can be taught
 - Inspection models are selected using digital inputs
- Flexible adaptation to the individual applications possible
 - Flexible adjustment of image window and operating distance
 - Flexible adjustment of parameters
- Fast commissioning
 - No image processing knowledge necessary
 - No programming necessary

Application

The SIMATIC MV220 image processing sensor is a complete image processing system for automatic inspection of color objects. It completes the product portfolio in the low-end image processing segment and high-end segment of conventional sensors.

Due to its high performance and simplicity, simple color inspection tasks are accessible that are too complex for the other image processing systems and which exclude themselves on grounds of cost.

The module is used in:

- Manufacturing and assembly systems for automobile industry suppliers and electronics;
- Checking the presence of colored components
- Packaging machines for blister packs and combined packs

- Checking for presence, part recognition and checking the location of colored objects
- Cup and bottle filling in the food & beverages industry
- Print inspection and parts identification for labels and covers

Design

The SIMATIC MV220 image processing sensor combines all the components required for the test in a compact housing:

- Rugged plastic/metal housing with degree of protection IP65
- Digital camera for evaluation of color pictures:
 - CMOS chip
 - Resolution of 640 x 480 pixels
- Continuously adjustable lens:
 - Variable image field from 40 x 30 mm to 200 x 150 mm
 - Variable object distance from 50 mm to 250 mm
- Integrated white lighting
- Laser-based alignment tool
- Operator controls and displays:
 - Input keys
 - Display
 - LEDs
- M12 plug and socket with connections for:
 - Power supply
 - Digital inputs and outputs
- M4 fastening holes for mechanical fixing system for industrial sensors

Function

The following functions are available:

- Teaching in the models using one or more good parts
- Inspecting an object using the features extracted during teach-in
- Inspection can be performed on stationary and moving objects
- Inspection of the object supplies a good/bad statement in accordance with the set threshold values
- The results are output on two digital outputs:
 - OK: Compliance of the object with the saved model is better or equal to the set threshold value
 - N_OK: Compliance of the object with the saved model is worse than or equal to the set threshold value

Mode of operation

Manual alignment of the sensor is supported by a laser-based alignment tool. Two laser beams project two light spots into the image window of the sensor.

The sensor is calibrated to the ambient conditions, menu-driven, based on the templates supplied.

The inspection tasks are taught by presenting one or more good objects. The result of teach-in can be saved in one of 16 data records. The learned inspection task can then be tested immediately in test mode.

To start the evaluation mode you have to select a trained object data record and switch to "RUN" mode. The sensor starts the evaluation after triggering.

Depending on the trained threshold values and the actual evaluated values, the result is output to the OK or N_OK digital outputs for a good or bad result respectively.

The inspection task can be changed by selecting a different data record (model) in "RUN" mode.

Any sensor faults or errors in operating the sensor are reported in the diagnostics. Evaluation mode continues or is terminated depending on the type of error.

Technical specifications

MV220 Vision Sensor

Image sensor

Image acquisition	CMOS sensor (color); 640 x 480 pixels
Size of the image field	Continuously variable; depending on the object distance
<ul style="list-style-type: none"> For object distance of 50 mm For object distance of 250 mm 	40 x 30 mm 200 x 150 mm
Number of distinguishable colors	Depending on inspection severity; 2048 colors / 64 colors / 16 colors
Inspection types	Matching, recognition
Inspection triggering	External; via digital input
Output of results	"OK" and "N_OK"; via LEDs and digital outputs

Lighting

Light source	Integrated white LEDs
Light intensity	800 LUX for object distance of 150 mm
External lighting	Controllable via digital output

Functions

Operator control	4-character text display and 4 operator buttons
Alignment tool	Using laser projection (laser class 2)
Number of models that can be stored	16; using digital inputs
Teach-in of models	Using "Teach-in"
Diagnostics messages	Using LED, text display and digital output
Operating status display	Using LED and digital output
Disabling operation of keys	Possible using digital input

Interfaces

Digital inputs	6 inputs, 24 V DC of which one trigger input (100 µs delay time) and 5 inputs for model selection and key disabling
Digital outputs	5 outputs; 24 V DC Outputs for results, 500 mA Outputs for diagnostics and external lighting, 100 mA Outputs for operating status, 20 mA
Connection of digital inputs and outputs	M12 socket and M12 plug, 8-pole
Mounting the sensor	Using M4 fixing holes

General specifications

Supply voltage	
<ul style="list-style-type: none"> Rated value Voltage range 	24 V DC 20.4 ... 28.8 V DC; with reverse polarity protection
Power consumption max.	2 A
Material	
<ul style="list-style-type: none"> Housing Lens cover 	Plastic, aluminum Plastic
Mechanical strength	
<ul style="list-style-type: none"> Oscillations Shock 	acc. to IEC61131-2 acc. to IEC61131-2

MV220 Vision Sensor

Dimensions (H x W x D) in mm	113 x 35 x 90
Degree of protection	IP65 acc. to DIN EN 60529
Ambient temperature	0 ... 45 °C
Weight	430 g

Selection and Ordering data

SIMATIC MV220

Color mark sensor for
inspecting colored objects;
size of image field 40 x
30 mm ... 200 x 150 mm;
operating unit, display unit
and LED lighting integrated;
incl. operating instructions
and templates

Order No.
6GF5 110-0AA00-0AA0

Accessories

M12 cable plug

With 5 m PUR cable, black,
shielded,
8-pole (8 x 0.25 mm²)

3RX8 000-0CB81-1GF0

M12 cable plugs

With 5 m PUR cable, black,
shielded,
8-pole (8 x 0.25 mm²)

3RX8 000-0CD81-1GF0

Round-steel fixing bar

Diameter = 12 mm, length = 200 mm,
for fixing system for sensors

3RX7 315

Diameter = 12 mm, length = 300 mm,
for fixing system for sensors

3RX7 316

Holding plate

For accommodating the
SIMATIC MV 220, use in
connection with fixing bar;
for fixing system for sensors

3RX7 326

Mounting base

With 12 mm receptacle
for sensor fixing system

3RX7 322

► Preferred type, available from stock.

Vision Sensors

SIMATIC MV220

Dimensions

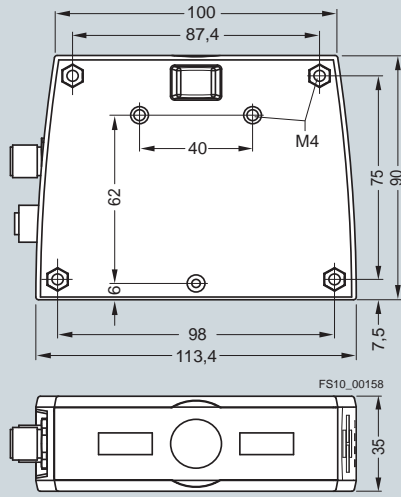

Schematics

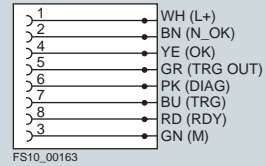

MV220 Vision Sensor, X1 interface

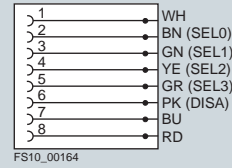

MV220 Vision Sensor, X2 interface



MV220 Vision Sensor, socket pin assignment

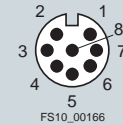

MV220 Vision Sensor, plug pin assignment

Overview



- Compact image processing sensor for the automatic testing of objects based on the specific surface contour or profile.
- A synthesis of high-performance image processing technology with simple, compact sensors
- High stability against ambient light
- For applications in manufacturing, the packaging industry and in the construction of special machines and serial machines
- Process-oriented implementation thanks to degree of protection IP65
- Integration in plant automation using digital inputs and outputs
- Quick familiarization with task thanks to the teach-in function

Benefits

- Degree of protection IP65 makes use in harsh industrial environments possible
- Costs for shielding against ambient light can normally be saved due to their high stability against ambient light
- Short changeover times thanks to simple model change
 - 16 inspection models can be taught
 - inspection models are selected using digital inputs
- Rapid startup thanks to Teach In
 - no image processing knowledge necessary
 - effective start-up and maintenance functions using diagnostics, checksums and statistical information
- Prevention of unauthorized operation through button disabling

Application

The SIMATIC MV230 height profile sensor is a complete image processing system for the automatic inspection of objects based on the specific height contour or profile. The split-beam method and laser projection on which it is based supports extremely rugged and reliable inspection. It completes the product portfolio in the low-end image processing segment and high-end segment of conventional sensors.

Its performance capability, simplicity and in particular the ruggedness of the test procedures can be used for inspection tasks that are too complex for other image processing systems and that must be disregarded for cost reasons.

The module is used in:

- Production and assembly systems for automotive suppliers and electrical engineering; checking, parts recognition and position inspection during assembly

- Packaging machines
Checking for presence, parts recognition and checking the location of objects
- General machine construction
Checking for presence, parts recognition and checking the location of objects

Design

The SIMATIC MV230 height profile sensor combines all the components required for the test in a compact enclosure:

- Rugged plastic/metal enclosure with degree of protection IP65
- Digital camera:
 - CMOS chip
 - Resolution of 750 x 480 pixels
- Integrated laser line of up to 75 mm in length
- Operator controls and displays:
 - Input keys
 - Display
 - LED displays
- M12 plug and socket with connections for:
 - Power supply
 - Digital inputs and outputs
- M4 fastening holes for mechanical fixing system for industrial sensors

Function

The following functions are available:

- Training of models based on a Good object
- Inspecting an object using the features extracted during teach-in
- Inspection of the object supplies a good/bad statement in accordance with the set threshold values (Q-LIMIT)
- Inspection results are output on two digital outputs:
 - OK: Compatibility of the object with the saved model is greater than or equal to the set threshold value
 - N_OK: Compatibility of the object with the saved model is less than the set threshold value

Operating principle

Manual alignment of the sensor is supported by the visible laser line.

The inspection task is trained by presenting a Good object. The object to be inspected or the object area to be inspected is positioned under the laser line.

For smaller objects, the length of the laser line range that can be evaluated can be reduced. The teach-in result is saved under one of 16 data records (model number).

The learned inspection task can then be tested immediately in test mode.

To start the evaluation mode you have to select a trained object data record and switch to "RUN" mode.

After triggering, the sensor starts evaluation. On the basis of the learned threshold values and the actual values of the evaluation, a result is output on the OK digital outputs (Good) or N_OK (Bad).

The inspection task can be changed by selecting a different data record (model) in "RUN" mode.

Any sensor faults or errors in operating the sensor are reported in the diagnostics. Evaluation mode continues or is terminated depending on the type of error.

Vision Sensors

SIMATIC MV230

Technical specifications

MV230 Vision Sensor	
Image capture and evaluation	
Image sensor	CMOS sensor; 750 x 480 pixels
Operating distance	210 ... 310 mm
Size of the image field	75 x 100 mm (for 310 mm operating distance)
Measuring principle	Split-beam (laser-based triangulation)
Test type	Profile evaluation
Accuracy/physical resolution	Height accuracy: 0.5 mm; Width accuracy: 0.2 mm
Triggering for image capture	Internal, freewheeling trigger; external trigger through digital input TRG
Max. cycle time	50 ms
Response time	16 ms
Output of results	"OK" and "N_OK"; via LEDs and digital outputs
Lighting	
Light source	Laser diode, red light
Laser protection class	2M (IEC 825-1, EN 60825-1)
Length of laser line	50 ... 75 mm
Functions	
Operation	4-character text display and 4 operator buttons
Number of models that can be taught	16
Teach-in of models	"Teach-in" on the sensor
Diagnostic messages	available; using LED, text display and digital output
Operating status display	available; using LED and digital output
Disabling operation of keys	possible; using digital input
Checking the set values	possible using global and model-specific checksums
Statistics function	available
Interfaces	
Digital inputs	6 inputs; for trigger (TRG), model selection (SEL0-3) and button disable (DISA)
Rated voltage	24 V DC
Input current	typ. 7 mA
Voltage range	Signal 1: 15 ... 30 V Signal 0: -3 ... 5 V
Input delay	3 ms typical (input TRG 0.1 ms)
Input characteristics curve	IEC1131, Type 1
Digital outputs	4 outputs; for result output (OK, N_OK), diagnostics (DIAG) and ready status (RDY)
Output voltage for "1" signal	L+ (-0.8 V)
Output current for "1" signal	500 mA (outputs OK, N_OK) 100 mA (DIAG) 20 mA (RDY)
Short-circuit protection at the outputs	Yes, electronic

MV230 Vision Sensor	
General data	
Supply voltage L+	
• Nominal value	24 V DC
• Voltage range	20.4 ... 28.8 V DC, with reverse polarity protection
Power consumption max.	2 A
Mechanical strength	
• Vibration	acc. to IEC61131-2
• Shock	acc. to IEC61131-2
Material	
• Enclosure	Plastic, aluminum
• Lens cover	plastic
Dimensions (H x W x D) in mm	161 x 35 x 112
Degree of protection	IP65 to DIN EN 60529
Ambient temperature	0 ... 45 °C, no moisture condensation
Weight	450 g

Selection and Ordering data	Order No.
SIMATIC MV230 ▶ Image processing sensor for the automatic inspection of objects and their position based on the specific surface contour and profile	6GF2 110-0BA00-0AA0
Accessories	
M12 cable plug ▶ With 5 m PUR cable, black, shielded, 8-pole (8 x 0.25 mm ²)	3RX8 000-0CB81-1GF0
M12 cable plugs ▶ With 5 m PUR cable, black, shielded, 8-pole (8 x 0.25 mm ²)	3RX8 000-0CD81-1GF0
Round-steel fixing bar	
Diameter = 12 mm, length = 200 mm, for fixing system for sensors ▶	3RX7 315
Diameter = 12 mm, length = 300 mm, for fixing system for sensors ▶	3RX7 316
Holding plate ▶	
For accommodating the SIMATIC MV230, use in connection with fixing bar; for fixing system for sensors	3RX7 326
Mounting base ▶	
With 12 mm receptacle for sensor fixing system	3RX7 322

▶ Preferred type, available from stock.

Dimensions

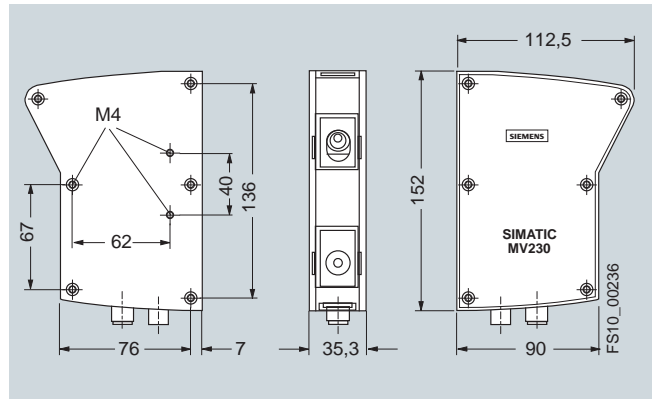

Schematics

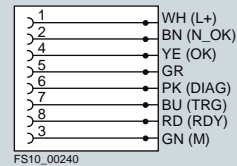

Plug connection for interface X1 and core color for M12 cable socket, 8-pin, length 5 m (Order No.: 3RX8 000-0CB81-1GF0)

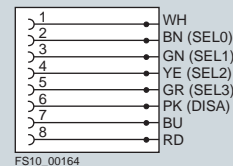

Plug connection for interface X2 and core color for M12 cable plug, 8-pin, length 5 m (Order No.: 3RX8 000-0CD81-1GF0)



Pin assignment X1, M8 connection for cable sockets



Pin assignment X2, M8 connection for cable plug

Vision Sensors

SIMATIC VS120

Overview

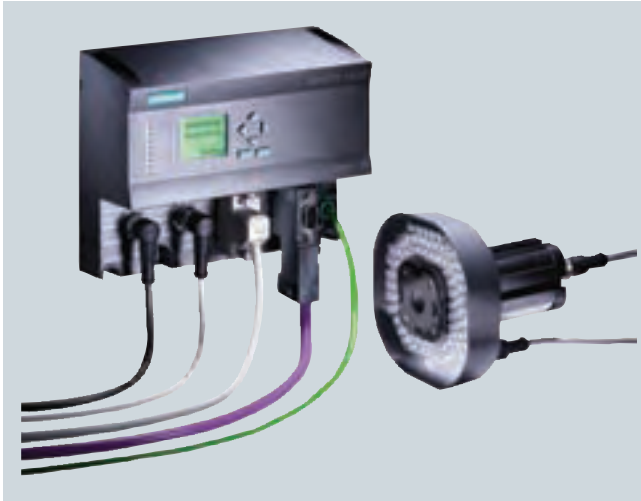

- Vision sensor for object finding and object size testing in reflected light
- VS120 finds and checks different objects and / or patterns, e.g.:
 - printed symbols (product markings on labels, packaging, etc.)
 - injection-molded parts,
 - ceramic elements,
 - ...
- Can be used in principle for the following applications:
 - position detection for Pick&Place applications,
 - checking the presence and position of objects in production,
 - checking the orientation of objects in infeed systems
- Easy configuration through presentation of the good object to be recognized. "Training" is done automatically by activating the training function of the unit.
- Parameter definition is done using the web-based operating interface and can be run on various platforms with the following requirements:
 - Browser (IE5.5 or higher),
 - JAVA-VM (MS, SUN).
- The web-based operator interface is also used for controlling the device from an HMI device. The same prerequisites apply here concerning the Browser and JAVA VM.
- Remote maintenance concept using web-based operator interface.
- Remote controlled with integrated digital inputs, PROFIBUS or PROFINET IO.
- Can be supplied as a complete package in several variations for different object sizes

Application

The intelligent vision sensor can be used for the following applications:

- Determining the position for Pick & Place applications
- Checking the presence and position of objects in production
- Checking the orientation of objects in infeed systems

Examples of possible inspection tasks and inspection objects:

- Checking the presence and position of symbols (warnings) and logos (corporate logos) on print media and packaging
- Checking the presence and position of objects in production for the quality assurance of assembly steps
- Checking the orientation of assembly items in infeed systems

Design

The SIMATIC VS 120 vision sensor offers the following image field sizes:

- 70 x 50 mm fixed-focus sensor head
- 40 x 30 mm fixed-focus sensor head
- Variable field of view with C/CS-Mount sensor head

The following components are required for use of the fixed-focus version of the SIMATIC VS120 vision sensor and are included in the scope of delivery:

- Sensor head
- Front lighting in the form of a ring light matched to the application and sensor head
- Evaluation unit
- Connecting cables
- CD with configuration software and assembly/operating instructions

To start up the fixed focus version you also need the following items (not included in the scope of delivery):

- Ethernet cable (see "Accessories") for connecting the evaluator to any web client. The web client, e.g. a PC with web browser installed, is used to adjust the sensor head and the lighting.

The following components are required for use of the C/CS mount version of the SIMATIC VS120 vision sensor and are included in the scope of delivery:

- Sensor head (without lens!)
- Evaluation unit
- Connecting cables (no connecting cable for lighting!)
- CD with configuration software and assembly/operating instructions

To start up the C/CS-Mount version you also need the following items (not included in the scope of delivery):

- C/CS-Mount lens with the required imaging properties
- Suitable light source and suitable connecting cable (see accessories)
- Ethernet cable (see "Accessories") for connecting the evaluator to any web client. The web client, e.g. a PC with web browser installed, is used to adjust the sensor head and the lighting.

Sensor head

The sensor head is equipped with:

- Extruded aluminium housing to degree of protection IP65 (fixed-focus version)
- CCD chip (640 x 480 quadratic pixels)
- Lens, permanently installed and non-adjustable (fixed focus version)
- Interface for digital transmission of image data to the evaluation unit

A sensor head for C/CS-Mount lenses is additionally available.

Evaluation unit

The evaluation unit has:

- Plastic housing, designed for cabinetless construction (IP40)
- Connections for
 - Supply voltage 24 V DC
 - Lighting
 - Sensor head
 - Digital inputs and outputs
 - Ethernet interface (DHCP-Client, DHCP-Server, fixed IP address)
 - PROFIBUS DP
- 4-line text display for operator prompting

- 6 keys for operating the unit
- User guidance with web-based operator interface (HTML, JAVA VM)
- Access protection by means of password.

The following communication services are included:

- PROFINET IO (slave)
- PROFIBUS DP V0 (slave),
- TCP/IP native

The analysis is carried out by a powerful digital signal processor.

Front lighting

- Designed as ring light pushed onto sensor head
- Can be dismantled, and secured with different orientation on the machine
- Housing with degree of protection IP65
- Equipped with red LEDs
- Operation in flash mode
- Power control for the flash integrated in the light

Function

- Training the object test parameters using one or more good objects
- Testing an object and/or pattern with the features taken from the training
- Testing can be performed on stationary and moving objects
- Checking for a match with the reference provides a good/poor indication after comparison with set-value criteria
- Test results output to three control outputs:
 - OK: trained object and/or pattern found based on features; degree of match greater than set value
 - N_OK: trained object and/or pattern NOT found based on features; degree of match NOT greater than set value
- Position information output via PROFIBUS DP, PROFINET IO, Ethernet or with converter to RS 232 interface
- Integrated DI/O enables "stand-alone" operation without additional controller.
- Remote control via PROFIBUS DP, PROFINET IO, DI/O or Ethernet
- Remote maintenance via web-based operator interface Intranet or Internet:
 - monitoring (live image in read mode)
 - diagnostics (fault image, log information, ...)
 - system administration (software update, ...)
 - error analysis for troubleshooting for faulty readings
- Actuation of ring lighting

Mode of operation

The following steps are required for using the SIMATIC VS120:

- Mount the vision sensor and lighting.
- Manual alignment of the camera, lighting check: This is handled with the web-server integrated in the unit and the web-based operator interface contained within. The operator interface displays the camera image. In the setup phase, the sensor head can be aligned with reference to the live image in the user interface. The user interface executes on any PC with Microsoft Internet Explorer and JAVA VM installation. If the sensor head adjustment is complete, the vision sensor automatically takes over the following procedures:
 - optimization of lighting control.
 - "Training" the image processing parameters by applying a reference object
 - the result of the training is stored under one of the 64 data records

- Starting the evaluation operation requires loading a trained object record and changing into the "RUN" operating mode. The VS120 starts the evaluation after triggering.
- Depending on the trained set values and the actual values of the evaluation, one of the digital control outputs OK (good result) or N_OK (poor result) is set.

The position information is output via the PROFIBUS DP, PROFINET IO or Ethernet interface.

Programming

SIMATIC VS120 is not programmed and parameters are not defined as on standard image processing systems. It is trained for its special task, finding and testing a special object. The SIMATIC VS120 is shown a good object and the device is "trained" to this object.

The training procedure can be performed while a conveyor system is running.

Up to 64 different data records can be stored in the device and can be called up at any time by the operator or can also be called up through an external controller.

Technical specifications

SIMATIC VS120 Vision Sensor	
Sensor head	
Image capture	CCD chip ¼", 640 x 480 square pixels; full frame shutter with automatic exposure time
Image data transfer	Triggered frame transfer
Available versions	<ul style="list-style-type: none"> • Fixed lens system for two different field of view sizes and mounting positions • One C/CS-mount version without lens.
<ul style="list-style-type: none"> • Large field of view 	Size of field of view: 70 x 50 mm for object sizes up to approx.: 60 x 40 mm Operating distance: 120 mm
<ul style="list-style-type: none"> • Small field of view 	Size of field of view: 40 x 30 mm for object sizes up to approx.: 34 x 24 mm Operating distance: 85 mm
<ul style="list-style-type: none"> • Variable field of view 	Lens can be selected by the user; hence freely selectable field of view size and object size Operating distance: dependent on the lens
Enclosure	Aluminum profile casing, anodized black
Dimensions (W x H x D) in mm	42 x 42 x 100
Degree of protection	IP65 according to DIN EN 60529 / VDE 0470-1
Ambient temperature	0 ... 50 °C
Mechanical strength	
<ul style="list-style-type: none"> • Vibrations 	1 g (60 ... 500 Hz)
<ul style="list-style-type: none"> • Shock 	70 g (6 ms, 3 shocks)

Vision Sensors

SIMATIC VS120

3

SIMATIC VS120 Vision Sensor	
Lighting	
Illuminant	LED, wavelength 630 nm (red), designed as a flash of 20 μs ... 10 ms, diffuse
Enclosure	Ring lamp with multiple fixing possibilities; plastic with plastic diffusing panel
Dimensions (W x H x D) in mm	102 x 102 x 26.5
Degree of protection	IP65 according to DIN EN 60529 / VDE 0470-1
Ambient temperature	0 ... 50 °C
Evaluation unit	
Operator controls	4-line text display and 6 operator buttons
Training	Fully-automatic training procedure
Number of types saved	64 different data records, can be selected via control button or digital inputs or PROFIBUS DP or PROFINET IO, network-fail-safe storage
Triggering inspection	External (via digital input, PROFIBUS DP or PROFINET IO)
Permitted object rate, max.	20 objects/s
Infeed direction of the objects	
• For external triggering	As required
• Setup software	Software for displaying the sensor image when mounting and adjusting the sensor head and lighting. The software is provided directly by the integrated web server and can be executed on every JAVA-capable browser (preferably IE6.0).
Enclosure	Plastic, all cables can be plugged in, suitable for installation without cabinet
Dimensions (W x H x D) in mm	170 x 140 x 76
Degree of protection	IP40 according to DIN EN 60529 / VDE 0470-1
Ambient temperature	0 ... 50 °C
Mechanical strength	
• Vibrations	1 g (60 ... 500 Hz)
• Shock	70 g (6 ms, 3 shocks)
Interfaces on evaluation unit	
• Digital inputs for 24 V DC	8; of which one interrupt-capable trigger input for standard binary sensors, 7 further PLC-capable control inputs
• Digital outputs for 24 V DC	6; of which 3 quality outputs 0.5 A are for the direct activation of pneumatic valves (15-pin Sub-D socket for inputs/outputs)
• Integrated PROFIBUS DP interface	DP (9 pin D-sub socket) to control the testing and real-time transmission of test results
• Integrated PROFINET IO interface	RJ45 (socket) for operating software, controlling the testing and real-time transmission of test results
• Integrated Ethernet interface	RJ45 (socket) for operating software, controlling the testing and real-time transmission of test results

SIMATIC VS120 Vision Sensor	
• Lighting control	4-pin circular connector (female) for power supply and for triggering the flash
• Sensor head interface	Digital interface (26 pin Sub-D socket) for connecting the VS120 sensor head
Power supply	
• Rated value	24 V DC
• Permitted range	20 ... 30 V DC
Current consumption, max.	4 A, of which up to 1.5 A for supplying the pneumatic valves that can be connected

Selection and Ordering data

SIMATIC VS120 Vision Sensor	Order No.
<p>Complete package for object testing; consisting of sensor head, LED front lighting, evaluation unit and the following cables:</p> <ul style="list-style-type: none"> • Cable between evaluation unit and sensor head, for lengths see below • Cable between lighting and evaluation unit (except for vision sensor with variable field of view), for length see below • Cable for power supply, length 10 m • Cable for connecting digital I/O devices, length 10 m 	
Incl. documentation package for SIMATIC VS120	
• Field of view 70 x 50 mm	
- With cable length 2.5 m	▶ B 6GF1 120-1AA
- With cable length 10 m	▶ B 6GF1 120-1AA01
• Field of view 40 x 30 mm	
- With cable length 2.5 m	▶ B 6GF1 120-2AA
- With cable length 10 m	▶ B 6GF1 120-2AA01
• Variable field of view, prepared for IP65 protective housing /note: supplied without light and light cable)	
- With cable length 2.5 m	▶ B 6GF1 120-3AB
- With cable length 10 m	▶ B 6GF 1 120-3AB01
▶ Preferred type, available from stock. B: Subject to export regulations AL = N and ECCN = EAR99S	

Accessories

Accessories for SIMATIC VS120 can be found starting with page 6/14.

Overview



Using a lens appropriate to the respective image evaluation task, the size of the image field at a desired working distance is determined for the camera image. In order to achieve reproducible statements from the image evaluation concerning the position, measurement or quality, the geometry and light intensity for the image must be kept constant within the permissible tolerances. For this reason, only lenses with a fixed focal length, aperture and focus are usually used. Motorized zoom, automatic aperture or autofocus are more detrimental than helpful.

Application

- **Measuring tasks and form recognition**
For high-precision, reproducible measurement of geometric variables, a full-format image is necessary to satisfy resolution requirements. Lenses must therefore be selected that have low distortion, high modulation depth and a small angle of view. Telecentric lenses are recommended for objects that have protrusions in the direction of the lens.
- **Quality control and parts recognition**
For recognition or inspection of the features of an object on the surface, the quality of the results depends on contrast and lack of distortion of the image. Macro lenses are often used at close range.
- **Code and text reading**
The recognition algorithms are tolerant to variations in form and size of the patterns. The requirements on quality of the optics are not very high. Low-cost lenses contribute towards the cost-effectiveness of image evaluation systems especially when they are used in more than one reading station.
- **Check for completeness and handling**
For localization and pattern recognition, the same criteria apply as for measurement tasks or parts recognition.

Function

Image types

The optical path of the lens is defined by its construction.

For **spherical lenses** the solid angle depends on the focal length, focus adjustment and aperture; all rays run through the focal point of the lens (central projection). Objects that are further away from the lens are depicted smaller; objects that are closer to the lens are depicted larger:

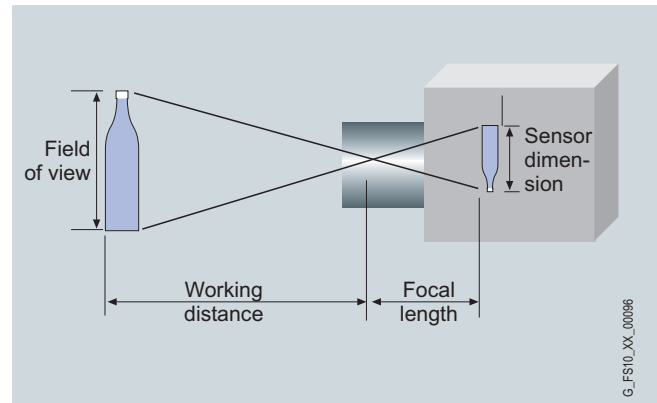

The required image field size (height and width of the image), the size of the sensor chip and the focal length of the lens determine the operating distance:

$$d = (f \times IS) / b$$

d = Operating distance (distance from lens to test object) in mm

f = Focal length of the lens in mm

IS = Size of image in the plane of the test object in mm

b = effective dimensions of the sensor in mm

In the case of lenses used in image processing systems, the focal length is fixed, the aperture and focus settings can be fixed. The focal length, the maximum focal aperture and the focusing range are normally specified on the lenses.

Focal distance

The focal length makes a statement about the angle of the image field or magnification of the lens.

The focal length of the lens is determined by the size of the required image field and the size of the camera chip when a specific distance has to be maintained. The most common chip sizes in cameras today are $\frac{1}{2}$ ", $\frac{1}{3}$ " and $\frac{1}{4}$ ". If the distance to the object lies below the adjustable focusing range of the lens, i.e. at close range, the focus can be adjusted using intermediate rings.

If the seating dimensions are designed for CS-Mount lenses in this camera, as for VS 100, a 5 mm intermediate ring can be used to adjust a C-Mount lens.

Aperture

Reduction of the light intensity by interrupting the optical path.

Focus

Setting the focus of the lens to a specific distance.

Depth of field

Depth of field is the area within which (in front of and behind the object) that is displayed with sufficient sharpness of focus. The larger the aperture (the smaller the aperture number), the smaller the depth of field.

Lenses with a larger focal length have a smaller depth of field, the effect is considerable for images at close range.

Vision Sensors

Lenses

Lens types

Lenses with smaller focal length are called wide-angle lenses, they can also be used at short operating distances, but produce intense distortion of the image. At a suitable distance, they have a large image field.

Lenses with a long focal length are called telephoto lenses; they have a large magnification but cannot be focused at close range, so macro lenses are used that can be focused by means of large telescopic extensions or intermediate rings. At a suitable distance, they have a small image field.

In the case of telecentric lenses, at least the optical path at the object end is almost parallel (parallel projection). This means

that objects at different distances are depicted in the same size. Objects can, however, only be displayed that are smaller than the diameter of the lens. It is not possible to adjust the range of focus with these lenses.

The optical characteristics can be restricted by means of optical filter glasses to counteract distortion in the image. Colored filters limit the spectral range, gray filters limit the light intensity and polarization filters restrict the transmission plane. Filters of this type can be attached either by using the internal thread or the flange on the front of the lens. The holder for the filter glass is designed to fit the lens.

Selection and Ordering data

Order No.

Order No.

Lenses for reading code and plain text and parts recognition



with fixed focal length, adjustable aperture and focus, with locking screw

- Mini lens 8.5 mm, 1:1.5 ▶ K **6GF9001-1BE01**
D = 42 mm, L = 47 mm;
successor type for
6GF9001-1BE
- Mini lens 12 mm, 1:1.4 ▶ K **6GF9001-1BL01**
D = 29.5 mm, L = 35.7 mm
- Mini lens 16 mm, 1:1.4 ▶ K **6GF9001-1BF01**
D = 29.5 mm, L = 37.2 mm;
successor type for
6GF9001-1BF
- Mini lens 25 mm, 1:1.4 ▶ K **6GF9001-1BG01**
D = 29.5 mm, L = 38.9 mm;
Successor type for
6GF9001-1BG
- Mini lens 35 mm, 1:1.6 ▶ K **6GF9001-1BH01**
D = 29.5 mm, L = 41.4 mm
- Mini lens 50 mm, 1:2.8 ▶ K **6GF9001-1BJ01**
D = 29.5 mm, L = 38.0 mm;
successor type for
6GF9001-1AH
- Mini lens 75 mm, 1:2.8 ▶ K **6GF9001-1BK01**
D = 34.0 mm, L = 63.6 mm

CS-Mount for C-Mount adapter ring 5 mm

▶ K **6GF9001-1AP02**

Accessories for utilizing the mini lenses at close range:

- Set of intermediate rings with 0.5 mm, 1.0 mm, 5.0 mm, 10.0 mm, 20.0 mm, 40 mm rings with 31 mm diameter C thread, attached between the lens and the camera body for shots in the macro range ▶ K **6GF9001-1BU**

Accessories for utilizing the mini lenses in telephoto range:

- Focal length extender, D = 30.5 mm, L = 17.9 mm with C thread, attached between the lens and the camera body for extending the focal length by a factor of 2 ▶ K **6GF9001-1BV**
- Lens intermediate ring 15 mm M **6GF9001-1AP01**

Filter for utilization of the mini lenses in the limited field of view:

- Infrared filter for lenses 6GF9001-1BF01, -1BG01, -1BH01, -1BJ01, -1BL01 ▶ M **6GF9001-2AD**
- Blue filter for lenses 6GF9001-1BF01, -1BG01, -1BH01, -1BJ01, -1BL01 ▶ M **6GF9001-2AE**
- Polarization filter for lenses 6GF9001-1BF01, -1BG01, -1BH01, -1BJ01, -1BL01 ▶ M **6GF9001-2AF**

▶ Preferred type, available from stock.

K: Subject to export regulations AL = 91999 and ECCN = EAR99H

M: Subject to export regulations AL = 91999 and ECCN = N

Dimensions

Lenses for reading code and plain text and parts recognition

Lens 6GF9 001-1BE01

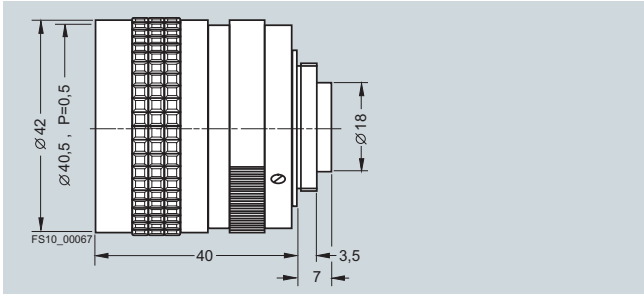

Lens 6GF9 001-1BK01

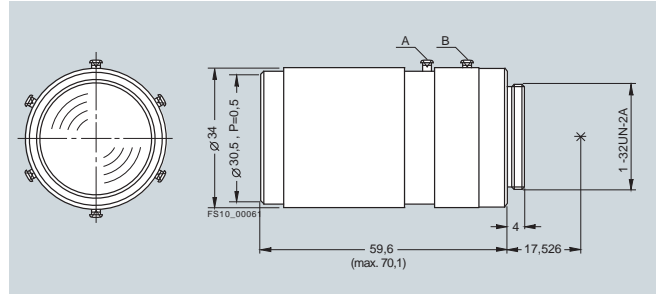

Lens 6GF9 001-1BF01

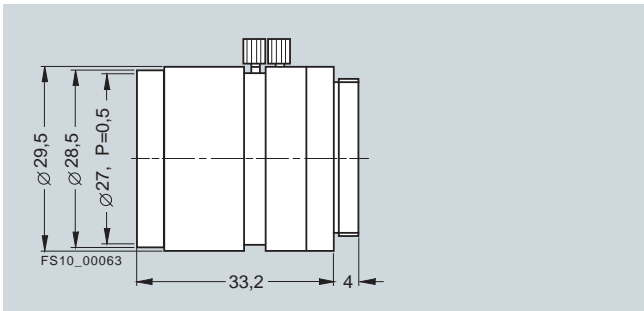

Lens 6GF9 001-1BG01

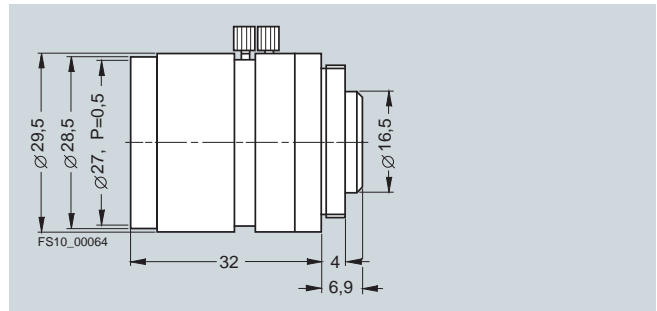

Lens 6GF9 001-1BH01

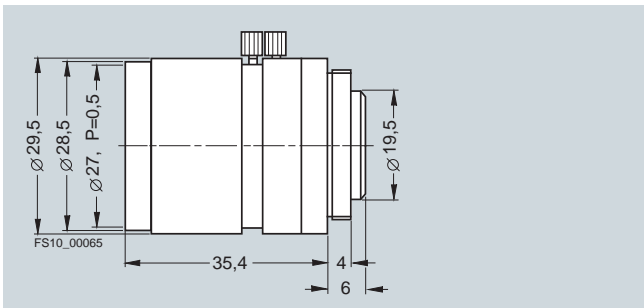

Lens 6GF9 001-1BJ01

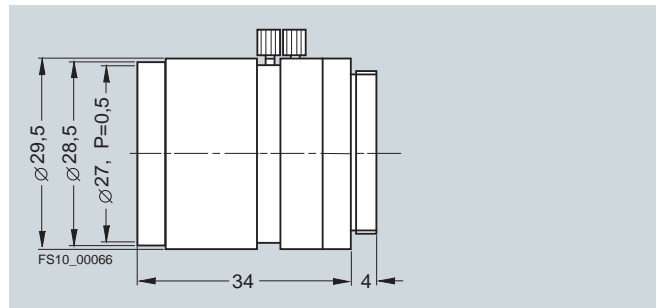

Lens 6GF9 001-1BL01

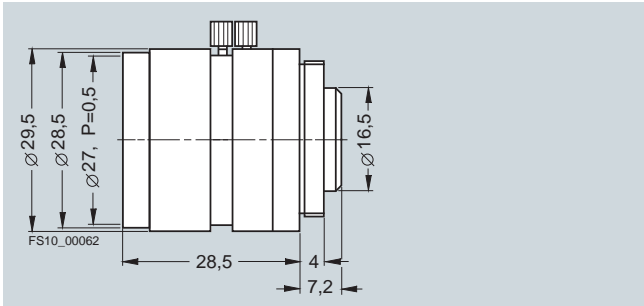

Accessories for lenses

Pentax intermediate ring set 6GF9 001-1BU:

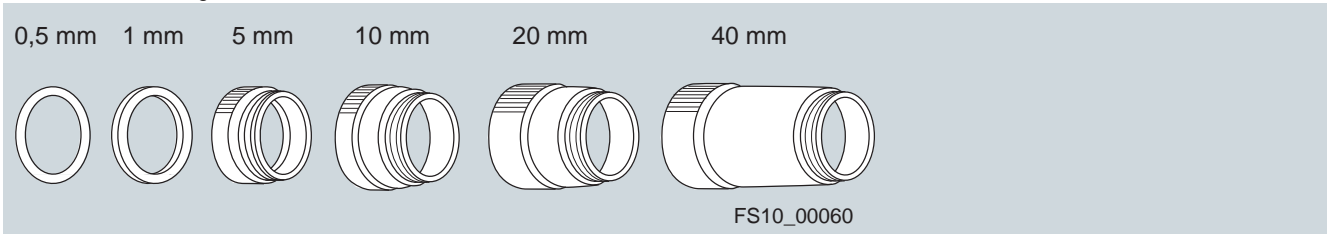

3

Vision Sensors

Lenses



Notes



Appendix

Order No. index

Order No.	Page	ECCN
6ES7392-1AJ00-0AA0	5/127	N
6ES7901-1BF00-0XA0	6/16	N
6GF1		
6GF1120-1AA	3/12	EAR99S
6GF1120-1AA01	3/12	EAR99S
6GF1120-2AA	3/12	EAR99S
6GF1120-2AA01	3/12	EAR99S
6GF1120-3AB	3/12	EAR99S
6GF1120-3AB01	3/12	EAR99S
6GF1130-1BA	6/13	EAR99S
6GF1130-1BA01	6/13	EAR99S
6GF1130-2BA	6/13	EAR99S
6GF1130-2BA01	6/13	EAR99S
6GF1130-3BB	6/13	EAR99S
6GF1130-3BB01	6/13	EAR99S
6GF1130-3BC	6/13	EAR99S
6GF1130-3BC01	6/13	EAR99S
6GF1130-4BA	6/13	EAR99S
6GF1130-4BA01	6/13	EAR99S
6GF2		
6GF2110-0BA00-0AA0	3/9	N
6GF3		
6GF3010-0AC00-0BM5	6/7	EAR99H
6GF3010-0AC00-0PC6	6/7	EAR99H
6GF3010-0AC00-0SC0	6/7	EAR99H
6GF3010-0HE15-0CS0	6/7	EAR99H
6GF3010-0HE15-0PS0	6/7	EAR99H
6GF3010-0HE15-1HD0	6/7	EAR99H
6GF3010-0HE15-1LD0	6/7	EAR99H
6GF3010-0HE15-1MD0	6/7	EAR99H
6GF3010-0HE15-1SD0	6/7	EAR99H
6GF3010-0HE15-2HD0	6/7	EAR99H
6GF3010-0HE15-2SD0	6/7	EAR99H
6GF3010-0LG14-0XX0	6/7	EAR99H
6GF3010-0LG15-0XX0	6/7	EAR99H
6GF3010-0LG16-0XX0	6/7	EAR99H
6GF3010-0LG17-0XX0	6/7	EAR99H
6GF3010-0LG18-0XX0	6/7	EAR99H
6GF3020-0AC00-0PS5	6/36, 6/39	EAR99H
6GF3020-0AC00-2BT0	6/24, 6/31	EAR99H
6GF3020-0AC10-3BT0	6/24, 6/31	EAR99H
6GF3020-0AC10-4BT0	6/24, 6/31	EAR99H
6GF3020-0AC10-5BT0	6/24, 6/31	EAR99H
6GF3020-0AC40-0AA2	6/23, 6/31	EAR99H
6GF3020-0AC40-0AA3	6/23, 6/31	EAR99H
6GF3020-0AC40-0AA4	6/23, 6/31	EAR99H
6GF3020-0AC40-0AA5	6/23, 6/31	EAR99H
6GF3020-0AC40-0AA6	6/23, 6/31	EAR99H
6GF3020-0AC40-0AA7	6/23, 6/31	EAR99H
6GF3020-0AC40-0AB0	6/23, 6/31	EAR99H
6GF3020-0AC40-0AB2	6/23, 6/31	EAR99H
6GF3020-0AC40-0AB3	6/23, 6/31	EAR99H
6GF3020-0AC40-0AB4	6/23, 6/31	EAR99H
6GF3020-0AC40-0AC0	6/23, 6/31	EAR99H
6GF3020-0AC40-0AC1	6/23, 6/31	EAR99H
6GF3020-0AC40-0AC3	6/23, 6/31	EAR99H

Order No.	Page	ECCN
6GF3020-0AC40-0AC4	6/23, 6/31	EAR99H
6GF3020-0AC40-0AC5	6/23, 6/31	EAR99H
6GF3020-0AC40-0AC6	6/23, 6/31	EAR99H
6GF3020-0AC40-0AH1	6/23, 6/31	EAR99H
6GF3020-0AC40-0AH2	6/23, 6/31	EAR99H
6GF3020-0AC40-0AP1	6/23, 6/31	EAR99H
6GF3020-0AC40-0AP2	6/23, 6/31	EAR99H
6GF3020-0AC40-0AP3	6/23, 6/31	EAR99H
6GF3020-0AC40-0AS1	6/23, 6/31	EAR99H
6GF3020-0AC40-0AV3	6/23	EAR99H
6GF3020-0AC50-0HR0	6/36, 6/39	EAR99H
6GF3020-0AC50-0LB1	6/36, 6/39	EAR99H
6GF3020-0AC50-0LB2	6/36	EAR99H
6GF3020-0AC50-0LD2	6/36	EAR99H
6GF3020-0AC50-0LD3	6/36, 6/39	EAR99H
6GF3020-0AC50-0WD1	6/36, 6/39	EAR99S
6GF3020-0AC51-0LB1	6/36, 6/39	EAR99H
6GF3020-0AC51-0LD3	6/36, 6/39	EAR99H
6GF3020-0HE15-1HV0	6/42	EAR99H
6GF3020-0HE15-1LV0	6/42	EAR99H
6GF3020-0HE15-1MV0	6/42	EAR99H
6GF3020-0HE15-1SV0	6/42	EAR99H
6GF3020-0HE15-2CV0	6/42	EAR99H
6GF3020-0HE15-2HV0	6/42	EAR99H
6GF3020-0HE15-2SV0	6/42	EAR99H
6GF3020-0HE40-0XX0	6/23	EAR99H
6GF3020-0HE40-0XX1	6/23	EAR99H
6GF3020-0HE40-0XX3	6/23	EAR99H
6GF3020-0HE40-0XX4	6/23	EAR99H
6GF3020-0HE40-0XX5	6/23	EAR99H
6GF3020-0HE40-2BT0	6/23	EAR99H
6GF3020-0HE45-0XX0	6/31	EAR99H
6GF3020-0HE45-0XX1	6/31	EAR99H
6GF3020-0HE45-0XX3	6/31	EAR99H
6GF3020-0HE45-0XX4	6/31	EAR99H
6GF3020-0HE45-0XX5	6/31	EAR99H
6GF3020-0HE45-2BT0	6/31	EAR99H
6GF3020-0HT40-0XX0	6/23	EAR99H
6GF3020-0HT40-0XX1	6/23	EAR99H
6GF3020-0HT40-0XX3	6/23	EAR99H
6GF3020-0HT40-0XX4	6/23	EAR99H
6GF3020-0HT40-0XX5	6/23	EAR99H
6GF3020-0HT40-2BT0	6/23	EAR99H
6GF3020-0HT45-0XX0	6/31	EAR99H
6GF3020-0HT45-0XX1	6/31	EAR99H
6GF3020-0HT45-0XX3	6/31	EAR99H
6GF3020-0HT45-0XX4	6/31	EAR99H
6GF3020-0HT45-0XX5	6/31	EAR99H
6GF3020-0HT45-2BT0	6/31	EAR99H
6GF3020-0HT50-0EU0	6/36	EAR99H
6GF3020-0HT50-0EX0	6/36	EAR99H
6GF3020-0HT50-0UX0	6/36	EAR99H
6GF3020-0HT50-0XX0	6/36	EAR99H
6GF3020-0HT51-0UX0	6/36	EAR99H
6GF3020-0HT51-0XX0	6/36	EAR99H
6GF3020-0HT52-0XX0	6/39	EAR99H

Order No.	Page	ECCN
6GF3020-0HT53-0XX0	6/39	EAR99H
6GF5		
6GF5110-0AA00-0AA0	3/5	N
6GF9		
6GF9001-1AP	3/14	EAR99H
6GF9001-1AP01	3/14	N
6GF9001-1AP02	6/7	EAR99H
6GF9001-1BE01	3/14	EAR99H ¹⁾
6GF9001-1BE01	6/7	EAR99H ¹⁾
6GF9001-1BF01	3/14	EAR99H ¹⁾
6GF9001-1BF01	6/7	EAR99H ¹⁾
6GF9001-1BG01	3/14	EAR99H ¹⁾
6GF9001-1BG01	6/7	EAR99H ¹⁾
6GF9001-1BH01	3/14	EAR99H ¹⁾
6GF9001-1BH01	6/7	EAR99H ¹⁾
6GF9001-1BJ01	3/14	EAR99H ¹⁾
6GF9001-1BJ01	6/7	EAR99H ¹⁾
6GF9001-1BK01	3/14	EAR99H ¹⁾
6GF9001-1BK01	6/7	EAR99H ¹⁾
6GF9001-1BL01	3/14	EAR99H ¹⁾
6GF9001-1BL01	6/7	EAR99H ¹⁾
6GF9001-1BU	3/14	EAR99H ¹⁾
6GF9001-1BU	6/7	EAR99H ¹⁾
6GF9001-1BV	3/14	EAR99H ¹⁾
6GF9001-2AD	3/14	N ¹⁾
6GF9001-2AE	3/14	N ¹⁾
6GF9002-7AA	6/16	N
6GF9002-7AA01	6/16	N
6GF9002-7AB	6/16	N
6GF9002-7AC	6/17	N
6GF9002-7AD	6/16	N
6GF9002-7BA	6/17	N
6GF9002-7CA	6/17	N
6GF9002-7DA	6/17	N
6GF9002-8CA	6/16	N
6GF9002-8CB	6/16	N
6GF9002-8CD	6/16	N
6GF9002-8CE	6/16	N
6GF9002-8CF	6/16	N
6GF9002-8CG	6/16	N
6GF9004-7AA	6/16	N
6GF9004-7AA01	6/16	N
6GF9004-7BA01	6/16	N
6GF9004-8BA	6/16	N
6GF9004-8BA01	6/16	N
6GF9004-8CA	6/16	N
6GF9004-8CA01	6/16	N
6GF9004-8DA01	6/16	N
6GK1		
6GK1901-0DB10-6AA0	5/123	N
6GK1901-0DM20-2AA5	5/123	EAR99H
6GK1901-1BB10-2AA0	5/123	N
6GK1901-1BB10-6AA0	5/123	N
6GK1905-0CA00	5/120	N
6GK1905-0CB00	5/120	N
6GK1905-0DA10	5/120	N

Order No.	Page	ECCN
6GK1905-0EA00	4/58, 4/114	N
6GK1905-0EA00	5/120	N
6GK1905-0EB00	4/58, 4/114	N
6GK1905-0EB00	5/120	N
6GK1905-0EC00	4/58, 4/114	N
6GK1905-0EC00	5/120	N
6GK1905-0FA00	5/120, 5/123	N
6GK1905-0FB00	5/120, 5/123	N
6GK1907-0AB10-6AA0	5/123	N
6GR1		
6GR1654-3AD20	2/121	N
6GR1654-3CH20	2/121	N
6GR1654-3CH21	2/121	N
6GR1802-7AD00	2/124	N
6GR1802-7BD05	2/124	N
6GR1804-7AD00	2/124	N
6GR1804-7BD05	2/124	N
6GR1806-7AD00	2/124	N
6GR1806-7BD05	2/124	N
6GR1808-7AD00	2/124	N
6GR1808-7BD05	2/124	N
6GR1810-0BD05	2/126	N
6GR1810-7BD05	2/126	N
6GR1811-0CJ05	2/126	N
6GR1811-7BD05	2/126	N
6GR6		
6GR6241-0AA00	2/35	EAR99H
6GR6241-0AB00	2/35	EAR99H
6GR6241-0BA00	2/35	EAR99H
6GR6241-0BB00	2/35	EAR99H
6GR6241-0NN00	2/35	EAR99H
6GR6241-0PA00	2/35	EAR99H
6GR6241-0PB00	2/35	EAR99H
6GR6241-0RS00	2/35	EAR99H
6GR6241-7AA00	2/35	N
6GR6241-7AB00	2/35	N
6GR6241-7BA00	2/35	N
6GR6241-7BB00	2/35	N
6GR6241-7NN00	2/35	N
6GR6241-7PA00	2/35	N
6GR6241-7PB00	2/35	N
6GR6241-7RS00	2/35	N
6GR6242-0AA00	2/35	EAR99H
6GR6242-0AB00	2/35	EAR99H
6GR6242-0BA00	2/35	EAR99H
6GR6242-0BB00	2/35	EAR99H
6GR6242-0RS00	2/35	EAR99H
6GR6242-7AA00	2/35	N
6GR6242-7AB00	2/35	N
6GR6242-7BA00	2/35	N
6GR6242-7BB00	2/35	N
6GR6242-7RS00	2/35	N
6GR6333-3KS00	2/7	EAR99H

Order No.	Page	ECCN
6GT2		
6GT2002-0EB00	5/117	N
6GT2002-0ED00	5/120	EAR99H
6GT2002-0FA10	5/127	N
6GT2002-0GA10	5/127	N
6GT2002-0HD00	5/125	EAR99H
6GT2002-0JD00	5/123	EAR99H
6GT2002-1HD00	5/125	EAR99H
6GT2002-1JD00	5/123	EAR99H
6GT2002-2CE00	5/130	N
6GT2002-2JD00	5/123	EAR99H
6GT2003-0AA10	5/27, 5/94	4A994X
6GT2080-2AA10	5/108	N
6GT2080-2AA10	5/15, 5/17, 5/20, 5/22, 5/25, 5/27, 5/42, 5/43, 5/45, 5/48, 5/50, 5/62, 5/63, 5/82, 5/85, 5/88, 5/90, 5/92, 5/94, 5/106, 5/117, 5/127, 5/130	N
6GT2080-3CA00-8AA5	5/133	EAR99S
6GT2080-3CA00-8AE5	5/133	EAR99S
6GT2080-3CC00-8AA5	5/133	EAR99S
6GT2080-3CC00-8AE5	5/133	EAR99S
6GT2080-3CE00-8AA5	5/133	EAR99S
6GT2080-3CE00-8AE5	5/133	EAR99S
6GT2080-3CG00-8AA5	5/133	EAR99S
6GT2080-3CG00-8AE5	5/133	EAR99S
6GT2090-0AN50	5/20, 5/22, 5/62, 5/82, 5/85, 5/90, 5/92	EAR99H
6GT2090-0AT12	5/20, 5/22, 5/62, 5/82, 5/85, 5/90, 5/92	EAR99H
6GT2090-0AT80	5/20, 5/22, 5/62, 5/82, 5/85, 5/90, 5/92	EAR99H
6GT2090-0BA00	5/20, 5/22, 5/62	EAR99H
6GT2090-0BA10	5/20, 5/22, 5/62	EAR99H
6GT2090-0BB00	5/130	N
6GT2090-0BB10	5/130	N
6GT2090-0BC00	5/117	N
6GT2090-0QA00	5/39, 5/57	EAR99H
6GT2090-0QA00-0AX3	5/39	EAR99H
6GT2090-0QB00	5/39, 5/57	EAR99H
6GT2090-0UA00	5/20, 5/22, 5/62	EAR99H
6GT2091-0AH50	5/130	EAR99H
6GT2091-0AN10	5/130	EAR99H
6GT2091-0AN20	5/130	EAR99H
6GT2091-0AN50	5/130	N
6GT2091-0EH20	5/127	N
6GT2091-0EH50	5/127	EAR99H

Order No.	Page	ECCN
6GT2091-0EN10	5/127	EAR99H
6GT2091-0EN20	5/127	EAR99H
6GT2091-0EN50	5/127	EAR99H
6GT2091-0FH20	5/120	EAR99H
6GT2091-0FH20	5/123, 5/125	EAR99H
6GT2091-0FH50	5/120	EAR99H
6GT2091-0FH50	5/123, 5/125	EAR99H
6GT2091-1CH20	5/117	N
6GT2091-1CH50	5/117	EAR99H
6GT2091-1CN10	5/117	EAR99H
6GT2091-1CN20	5/117	EAR99H
6GT2091-1CN50	5/117	N
6GT2091-2AN10	5/130	N
6GT2091-2AN50	5/130	EAR99H
6GT2091-2CH20	5/117	EAR99H
6GT2091-2EH20	5/127	EAR99H
6GT2091-2EH50	5/127	EAR99H
6GT2091-2EN10	5/127	N
6GT2091-2EN50	5/127	N
6GT2190-0AA00	5/9, 5/10, 5/36, 5/72	N
6GT21900AB00	5/10, 5/36, 5/72	N
6GT2190-0AB00	5/9	N
6GT2300-0AA00	5/9	EAR99H
6GT2300-0BB00	5/10	N
6GT2300-0CD00	5/11	N
6GT2300-0CE00	5/12	N
6GT2301-0CA00	5/20	N
6GT2301-2BB00	5/25	N
6GT2302-2CE00	5/130	EAR99H
6GT2302-2EE00	5/130	N
6GT2303-0AA10	5/27	4A994X
6GT2303-1AA00	5/27	EAR99H
6GT2303-1CA00	5/63	EAR99H
6GT2305-0AA00	5/15	N
6GT2305-0AB00	5/17	N
6GT2305-0CA00	5/20	N
6GT2390-0AA00	5/9	EAR99H
6GT2390-0BA00	5/130	N
6GT2390-1AA00	5/15, 5/17, 5/20	N
6GT2390-1AB00	5/62, 5/82, 5/85, 5/90, 5/92, 5/130	EAR99H
6GT2391-0BH50	5/130	N
6GT2391-0BN20	5/130	N
6GT2391-1AH50	5/130	N
6GT2391-1BN10	5/25, 5/130	N
6GT2391-1BN25	5/25, 5/130	N
6GT2391-1DH50	5/15, 5/17, 5/20	EAR99H
6GT2398-1AF00	5/22	N
6GT2398-1CA00	5/22, 5/45	N
6GT2398-1CB00	5/22, 5/45	N