

W 140: Miniature Photoelectric Switch Series with Large Scanning Ranges



- Photoelectric proximity switch with adjustable scanning distance and background suppression (BGS): Scanning distance = adjustable up to 500 mm.

The integrated W 140 electronics has parameters comparable with the “big ones” and convenient W 140 details simplify handling for mounting, operation startup and maintenance, for example:

- Sensitivity/scanning distance adjustment
- Operating reserve display
- Optional connection cable or M 8 plug, 3 pin or 4 pin.

The M 8 plug, 3 pin, model especially provides an extremely simple solution for the island technologies being used increasingly these days. Distributor boxes for plug modules or bus systems: plug W 140 and play.

All this and more make the W 140 very interesting for the branches storage and conveyor technology, semi-conductor industry, electronics assembling, packaging technologies, handling and assembly systems and special mechanical engineering.

	BGS Photoelectric proximity switches
	Photoelectric proximity switches energetic
	Photoelectric reflex switches
	Through-beam photoelectric switches

The W 140 is a complete photoelectric switch series in miniature housing. It especially provides extensive scanning ranges for challenging requirements.

The W 140 highlights:

- Through-beam photoelectric switches:
Scanning range = 15 m
Accessories: Slotted masks, polarizing filter tip adapters
- Photoelectric reflex switch with polarizing filter:
Scanning range = 6 m (PL 80 A)
- Energetic photoelectric proximity switch:
Scanning distance = 900 mm; for standard scanning jobs



Scanning distance
2 ... 500 mm

Photoelectric proximity switch

- With background suppression (BGS), consequently reliable detection of dark objects in front of a light background
- Switching point largely independent of object color and surface
- Scanning distance can be adjusted stepless, scanning distance control (5 turns)
- Optionally with time release delay $t_{OFF} = 0 \dots 100 \text{ ms}$

Dimension illustration

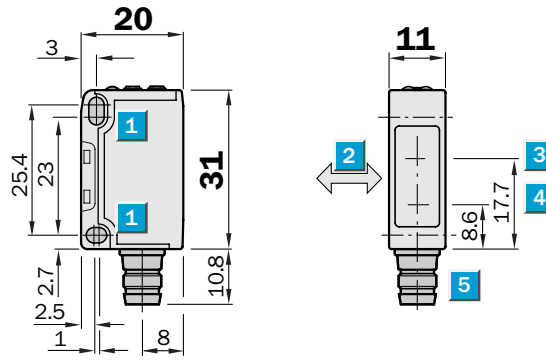

Setting options

WTB 140-P132	WTB 140-P122
WTB 140-N132	WTB 140-N122
WTB 140-P330	WTB 140-P420
WTB 140-N330	WTB 140-N420
WTB 140-P430	
WTB 140-N430	

- 1 Mounting hole $\varnothing 3.2 \text{ mm}$ for M 3
- 2 Standard direction of the material to be scanned
- 3 Optics center, receiver
- 4 Optics center, transmitter
- 5 M 8 plug, 3/4 pin or connection cable
- 6 Green LED indicator: light reception with operating reserve > 1.1
- 7 Orange LED indicator: switching output active
- 8 Scanning distance control (5 turns)
- 9 Light/dark rotary switch: L = light switching, D = dark switching
- 10 OFD, selector switch (270°) switch-off delay t_{OFF} : $t = 0 \text{ s (OFF)} \dots 0.1 \text{ s}$

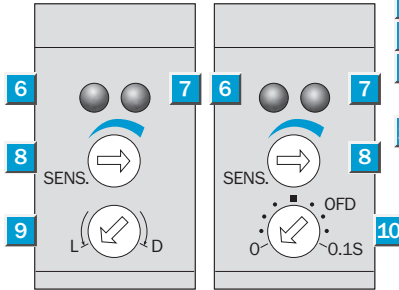

WTB 140 Operating diagram

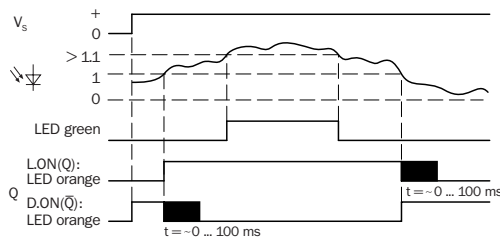

t : look at technical data

Connection type

WTB 140-P132	WTB 140-P122	WTB 140-P430	WTB 140-P420	WTB 140-P330
WTB 140-N132	WTB 140-N122	WTB 140-N430	WTB 140-N420	WTB 140-N330

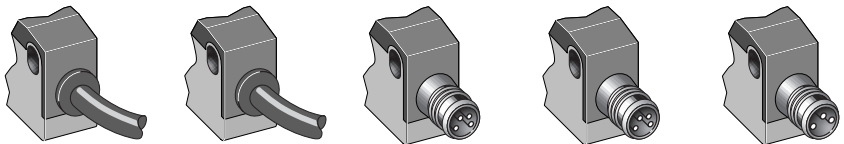

3 x 0.18 mm ²	4 x 0.18 mm ²	4 pin, M 8	4 pin, M 8	3 pin, M 8

Accessories

Cable receptacles
Mounting bracket



Technical data		WTB 140	-P132	-P330	-P430	-N132	-N330	-N430	-P122	-P420	-N122	-N420
Scanning distance¹⁾, adjustable	Max. 2 ... 500 mm, min. 2 ... 15 mm											
Scanning distance setting	Potentiometer, 5 rotations											
Background suppression	In % of the set scanning distance ²⁾											
Light source³⁾	LED, visible red light											
Light spot diameter	Approx. 15 mm at 200 mm distance											
Transmitter dispersion angle	Approx. 4.3°											
Supply voltageV_s⁴⁾	10 ... 30 V DC											
Ripple ⁵⁾	± 10 %											
Current consumption ⁶⁾	≤ 30 mA											
Switching outputs	PNP, open collector: Q											
	NPN, open collector: Q											
Switching type ⁷⁾ Light/dark switching	per rotary switch ⁸⁾											
	per control wire L/D ⁹⁾											
Output current I_A max.	100 mA											
Response time¹⁰⁾	≤ 0.5 ms											
Signal frequency max.¹¹⁾	1000/s											
Time delay: t_{OFF} (switch-off delay)	Selectable using rotary potentiometer											
Time range	Adjust 0 ... 100 ms; potentiometer 270°											
Type of connection	conec. cable, PVC, 2 m ¹²⁾ ; 3 x 0.18 mm ² , Ø 4.0 mm											
	PVC, 2 m ¹²⁾ ; 4 x 0.18 mm ² , Ø 4.0 mm											
	plug M 8 plug, 3 pin											
	M 8 plug, 4 pin											
VDE protection class¹³⁾	<input type="checkbox"/>											
Enclosure rating	IP 67											
Circuit protection¹⁴⁾	A, B, C, D											
Ambient temperature	Operation -25 ... +55 °C											
	Storage -40 ... +70 °C											
Weight	with connec. cable 2 m	Approx. 53 g										
	with M 8 plug	Approx. 9 g										
Housing material	Housing ABS; optics: PC											

- | | | | |
|--|--|--|---|
| 1) Object with 90 % reflectance (with reference to standard white according to DIN 5033) | 5) Must be within V_s tolerances | 11) With light/dark ratio 1 : 1 | C = Interference suppression |
| 2) See characteristic curve | 6) Without load | 12) Do not bend cable below 0 °C | D = Outputs overcurrent and short-circuit protected |
| 3) Average service life 100,000 h at $T_{ij} = +25 °C$ | 7) Adjustable | 13) Rated voltage 50 V DC | 15) Black = 6 % reflectance |
| 4) Limit values | 8) L = light switching, D = dark switching | 14) A = V_s connections reverse-polarity protected | Gray = 18 % reflectance |
| | 9) + V_s = light switching | B = Inputs and outputs reverse-polarity protected | White = 90 % reflectance |
| | 10) With resistive load | | |

Scanning distance

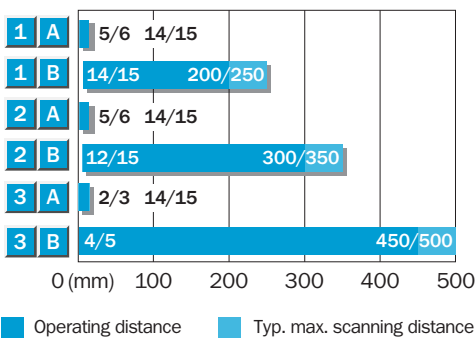

- | | |
|---|---|
| 1 | Scanning range on black ¹⁵⁾ , white background |
| 2 | Scanning range on gray ¹⁵⁾ , white background |
| 3 | Scanning range on white ¹⁵⁾ , white background |
| A | Scanning range control set to MIN |
| B | Scanning range control set to MAX |

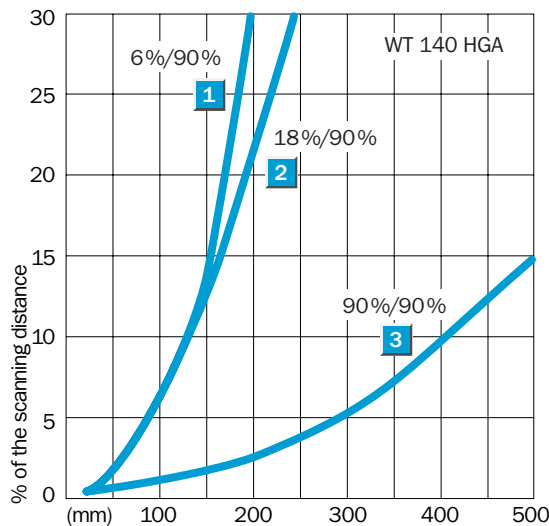

Ordering information

Type	Order no.
WTB 140-P132	6 012 640
WTB 140-P330	6 012 642
WTB 140-P430	6 012 643
WTB 140-N132	6 012 636
WTB 140-N330	6 012 638
WTB 140-N430	6 012 639
WTB 140-P122	6 012 632
WTB 140-P420	6 012 635
WTB 140-N122	6 012 628
WTB 140-N420	6 012 631

Scanning distance
0 ... 900 mm
 Photoelectric proximity switch

- Energetic photoelectric proximity switch for standard applications
- Adjustable switching point
- Equipment plug optionally M 8, 3 pin or 4 pin
- LED indicator: operating reserve

Dimension illustration

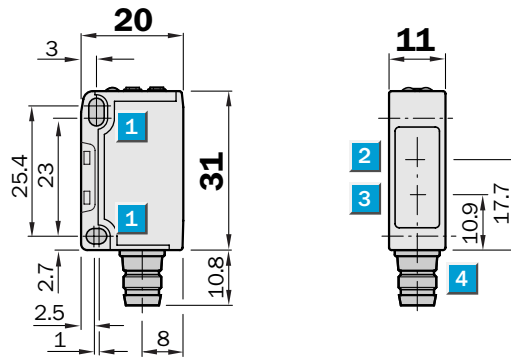

Setting options

- WTE 140-P132
- WTE 140-N132
- WTE 140-P330
- WTE 140-N330
- WTE 140-P430
- WTE 140-N430

- 1** Mounting hole \varnothing 3.2 mm for M 3
- 2** Optics center, receiver
- 3** Optics center, transmitter
- 4** M 8 plug, 3/4 pin or connection cable
- 5** Green LED indicator: light reception with operating reserve > 1.1
- 6** Orange LED indicator: switching output active
- 7** Sensitivity setting (270°)
- 8** Light/dark rotary switch: L = light switching, D = dark switching

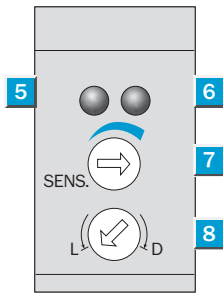

WTE 140 operating diagram

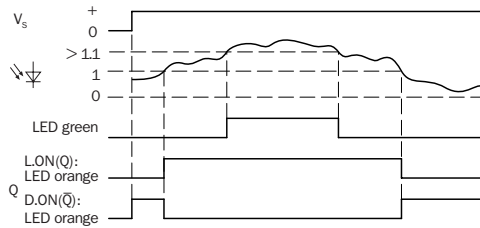

Connection type

WTE 140-P132	WTE 140-P430	WTE 140-P330
WTE 140-N132	WTE 140-N430	WTE 140-N330

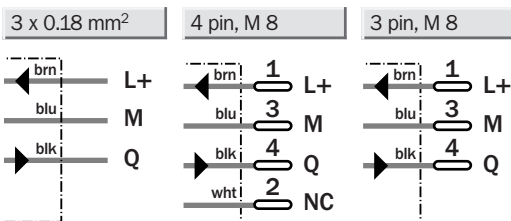
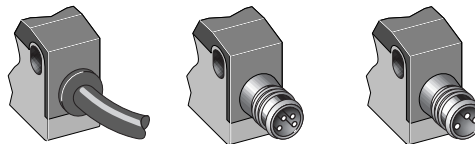

Accessories

Cable receptacles
Mounting bracket



Technical data		WTE 140	-P132	-P330	-P430	-N132	-N330	-N430				
Scanning distance typ. max.	0 ... 900 mm ¹⁾											
Operating distance	0 ... 800 mm ¹⁾											
Sensitivity, adjustable	Potentiometer, 270°											
Light source ²⁾	LED, visible red light											
Light spot diameter	Approx. 25 mm at 300 mm distance											
Transmitter dispersion angle	Approx. 4.8°											
Supply voltage V_s ³⁾	10 ... 30 V DC											
Ripple ⁴⁾	± 10 %											
Current consumption ⁵⁾	≤ 30 mA											
Switching outputs	PNP, open collector: Q											
	NPN, open collector: Q											
Switching type, adjustable	Light/dark switching per rotary switch ⁶⁾											
Output current I_A max.	100 mA											
Response time ⁷⁾	≤ 0.5 ms											
Signal frequency max. ⁸⁾	1000/s											
Type of connection	connec. cable, PVC, 2 m ⁹⁾ ; 3 x 0.18 mm ² , Ø 4.0 mm											
	plug M 8 plug, 3 pin											
	M 8 plug, 4 pin											
VDE protection class ¹⁰⁾	<input type="checkbox"/>											
Enclosure rating	IP 67											
Circuit protection ¹¹⁾	A, B, C, D											
Ambient temperature	Operation -25...+55 °C											
	Storage -40...+70 °C											
Weight	with connection cable 2 m	Approx. 53 g										
	with M 8 plug	Approx. 9 g										
Housing material	Housing ABS; optics: PC											

- | | | | |
|---|---|---------------------------------|---|
| 1) Object with 90% reflectance (with reference to standard white according to DIN 5033) | 3) Limit values | 7) With resistive load | 11) A = V _s connections reverse-polarity protected |
| 2) Average service life 100,000 h at T _U = +25 °C | 4) Must be within V _s tolerances | 8) With light/dark ratio 1:1 | B = Inputs and outputs reverse-polarity protected |
| | 5) Without load | 9) Do not bend cable below 0 °C | C = Interference suppression |
| | 6) L = light switching, D = dark switching | 10) Rated voltage 50 V DC | D = Outputs overcurrent and short-circuit protected |

Scanning distance

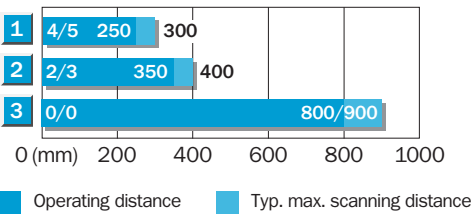

- 1 Scanning range on black, 6% reflectance
- 2 Scanning range on gray, 18% reflectance
- 3 Scanning range on white, 90% reflectance

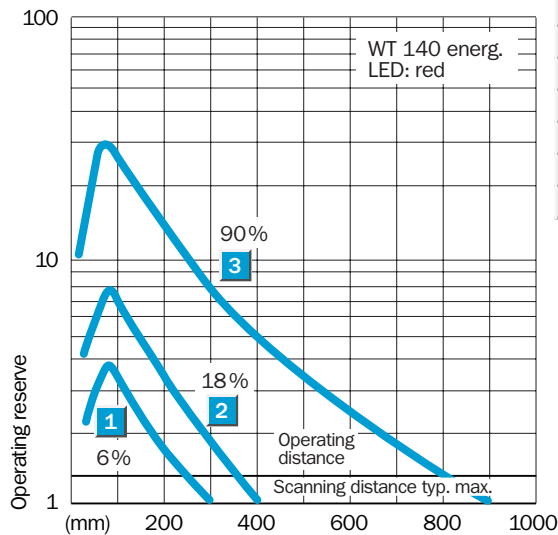

Ordering information

Type	Order no.
WTE 140-P132	6 012 616
WTE 140-P330	6 012 618
WTE 140-P430	6 012 619
WTE 140-N132	6 012 612
WTE 140-N330	6 012 614
WTE 140-N430	6 012 615

Scanning range
0.01 ... 6.0 m

Photoelectric reflex switch

- Polarizing filter, consequently reliable detection of objects even with shiny surfaces
- Also suitable for “Diamond Grade” reflecting tape
- Adjustable sensitivity
- LED indicator: operating reserve

Dimension illustration

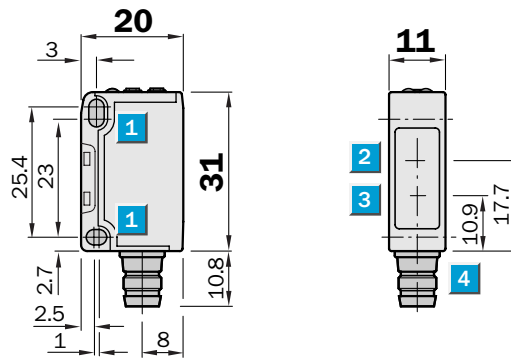

Setting options

WL 140-P132
WL 140-N132
WL 140-P330
WL 140-N330
WL 140-P430
WL 140-N430

- 1 Mounting hole \varnothing 3.2 mm for M 3
- 2 Optics center, receiver
- 3 Optics center, transmitter
- 4 M 8 plug, 3/4 pin or connection cable
- 5 Green LED indicator: light reception with operating reserve > 1.1
- 6 Orange LED indicator: switching output active
- 7 Sensitivity setting (270°)
- 8 Light/dark rotary switch: L = light switching, D = dark switching

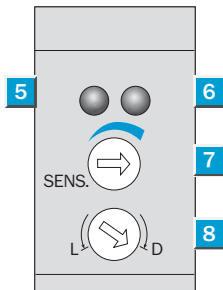

WL 140 operating diagram

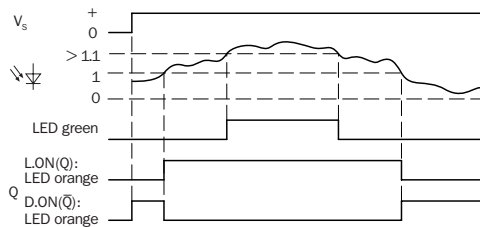

Connection type

WL 140-P132	WL 140-P430	WL 140-P330
WL 140-N132	WL 140-N430	WL 140-N330

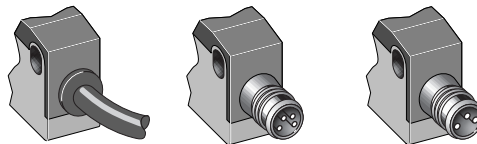

3 x 0.18 mm²

4 pin, M 8

3 pin, M 8

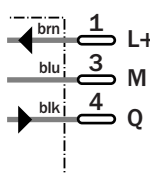
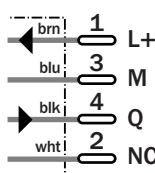
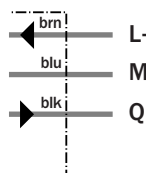

Accessories

Cable receptacles
Mounting bracket
Reflectors



Technical data		WL 140	-P132	-P330	-P430	-N132	-N330	-N430				
Scanning range typ. max./on reflector	0.01 ... 6.0 m/PL 80 A											
	0.01 ... 4.0 m/P 250											
	0.01 ... 1.5/ P 45 ¹⁾											
Operating range	0.01 ... 5.0 m/PL 80 A											
	0.01 ... 3.5 m/P 250											
	0.01 ... 1.2 m/P 45 ¹⁾											
Sensitivity, adjustable	Potentiometer, (270°)											
Light source ²⁾	LED, visible red light with polarizing filter											
Light spot diameter	Approx. 150 mm at 2.5 m distance											
Transmitter dispersion angle	Approx. 3.5°											
Supply voltage V _s ³⁾	10 ... 30 V DC											
Ripple ⁴⁾	± 10 %											
Current consumption ⁵⁾	≤ 30 mA											
Switching outputs	PNP, open collector: Q											
	NPN, open collector: Q											
Switching type, adjustable	Light/dark switching per rotary switch ⁶⁾											
Output current I _A max.	100 mA											
Response time ⁷⁾	≤ 0.5 ms											
Signal frequency max. ⁸⁾	1000/s											
Type of connection	connec. cable PVC, 2 m ⁹⁾ ; 3 x 0.18 mm ² , Ø 4.0 mm											
	plug M 8 plug, 3 pin											
	M 8 plug, 4 pin											
VDE protection class ¹⁰⁾	□											
Enclosure rating	IP 67											
Circuit protection ¹¹⁾	A, B, C, D											
Ambient temperature	Operation -25 ... +55 °C											
	Storage -40 ... +70 °C											
Weight	with connection cable 2 m	Approx. 53 g										
	with M 8 plug	Approx. 9 g										
Housing material	Housing ABS; optics: PMMA											

- | | | | |
|--|---|---------------------------------|---|
| 1) Reflector P 45 supplied with equipment | 3) Limit values | 7) With resistive load | 11) A = V _s connections reverse-polarity protected |
| 2) Average service life 100.000 h at T _J = +25 °C | 4) Must be within V _s tolerances | 8) With light/dark ratio 1 : 1 | B = Inputs and outputs reverse-polarity protected |
| | 5) Without load | 9) Do not bend cable below 0 °C | C = Interference suppression |
| | 6) L = light switching, D = dark switching | 10) Rated voltage 50 V DC | D = Outputs overcurrent and short-circuit protected |

Scanning ranges and operating reserves

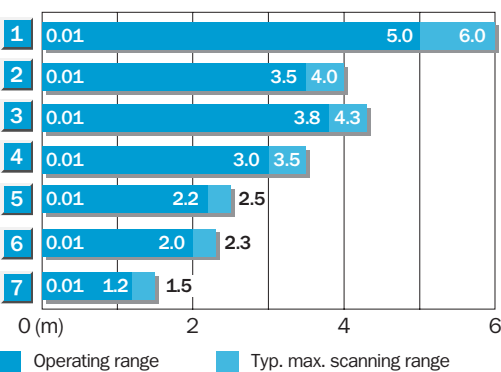

Reflector type	Operating range
1 PL 80 A	0.01 ... 5.0 m
2 P 250	0.01 ... 3.5 m
3 PL 50 A/PL 40 A	0.01 ... 3.8 m
4 PL 30 A/PL 31 A	0.01 ... 3.0 m
5 PL 20 A	0.01 ... 2.2 m
6 Reflective tape Diamond Grade	0.01 ... 2.0 m
7 P 45	0.01 ... 1.2 m

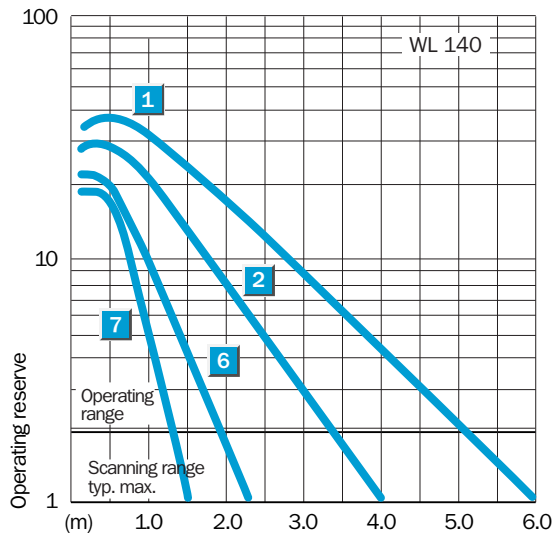

Ordering information

Type	Order no.
WL 140-P132	6 012 608
WL 140-P330	6 012 610
WL 140-P430	6 012 611
WL 140-N132	6 012 604
WL 140-N330	6 012 606
WL 140-N430	6 012 607

Scanning range
15 m

Through-beam photoelectric switch

- Polarizing filter tip adapters (accessories), consequently no mutual interference when WS/WE 140 are mounted in pairs
- Slotted masks for detecting small parts or for positioning jobs
- Adjustable sensitivity
- LED indicator: operating reserve

Dimension illustration

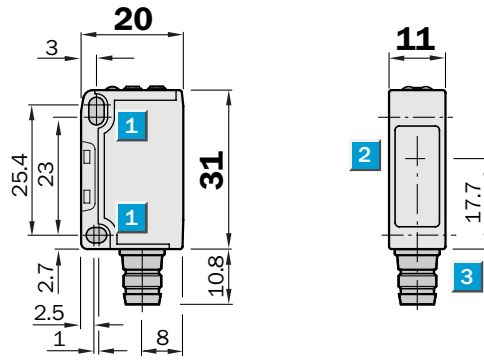

Setting options

WS/WE 140-P132	WS/WE 140-N330
WS/WE 140-N132	WS/WE 140-P430
WS/WE 140-P330	WS/WE 140-N430

- 1** Mounting hole Ø 3.2 mm for M 3
- 2** Optics center – WS 140 transmitter
Optics receiver – WE 140 transmitter
- 3** M 8 plug, 3/4 pin or connection cable
- 4** Green LED indicator: light reception with operating reserve > 1.1 (WE 140)
- 5** Orange LED indicator: Switching output active
- 6** Sensitivity setting (270°, WE 140)
- 7** Light/dark rotary switch: L = light switching, D = dark switching (WE 140)

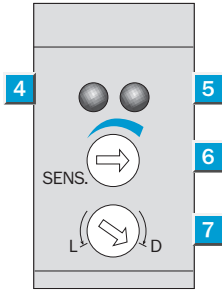

WE 140 operating diagram

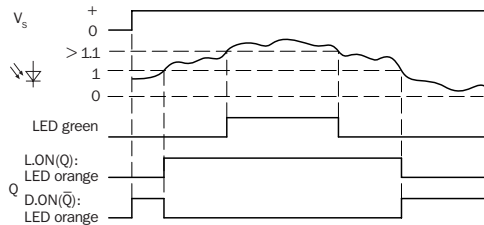

Connection type

WS/WE 140-P132	WS/WE 140-P330	WS/WE 140-P430
WS/WE 140-N132	WS/WE 140-N330	WS/WE 140-N430

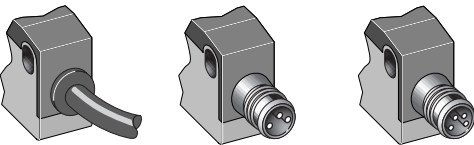

WS/WE 140 mounting in pairs

No mutual interference thanks to use of polarizing filter tip adapters BL-140-POLF

- e.g., Pair 1: BL-140-POLF with polarizing level ⇔
- Pair 2: BL-140-POLF with polarizing level ⇕

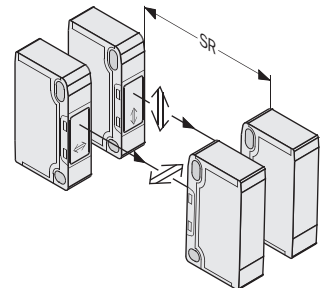

Accessories

Cable receptacles
Mounting bracket

	2 x 0.18 mm ²	3 pin, M 8	4 pin, M 8
Transmitter	L+ (brn) M (blu)	L+ (brn) 1 M (blu) 3 NC (blk) 4	L+ (brn) 1 M (blu) 3 NC (blk) 4 NC (wht) 2
Receiver	L+ (brn) M (blu) Q (blk)	L+ (brn) 1 M (blu) 3 Q (blk) 4	L+ (brn) 1 M (blu) 3 Q (blk) 4 NC (wht) 2

Technical data	WS/WE 140	-P132	-P330	-P430	-N132	-N330	-N430				
-----------------------	-----------	-------	-------	-------	-------	-------	-------	--	--	--	--

Scanning range typ. max.	15 m										
Operating range	12 m										
Operating range with polarizing filter	5.0 m										
Operating range with mask 2.0 m	4.0 m										
Operating range with mask 1.0 m	2.0 m										
Operating range with mask 0.5 m	1.0 m										
Sensitivity, adjustable	Potentiometer, 270°										
Light source ⁴⁾	LED, visible red light										
Light spot diameter	Approx. 650 mm at 12 m distance										
Transmitter dispersion angle	Approx. 3.1°										
Receiver reception angle	Approx. 15°										
Supply voltage V_s ²⁾	10 ... 30 V DC										
Ripple ³⁾	± 10 %										
Current consumption ⁴⁾ Transm./receiv.	≤ 15 mA/≤ 20 mA										
Switching outputs	PNP, open collector: Q										
	NPN, open collector: Q										
Switching type, adjustable (WE 140)	Light/dark switching per rotary switch ⁵⁾										
Output current I_A max.	100 mA										
Response time ⁶⁾	≤ 0.5 ms										
Signal frequency max. ⁷⁾	1000/s										
Type of connection											
WS 140 connection cable	PVC, 2 m ⁸⁾ ; 2 x 0.18 mm ² , Ø 4.0 mm										
WE 140	PVC, 2 m ⁸⁾ ; 3 x 0.18 mm ² , Ø 4.0 mm										
plug	M 8 plug, 3 pin										
	M 8 plug, 4 pin										
VDE protection class ⁹⁾	<input type="checkbox"/>										
Enclosure rating	IP 67										
Circuit protection ¹⁰⁾	WS 140 A										
	WE 140 A, B, C, D										
Ambient temperature	Operation -25 ... +55 °C										
	Storage -40 ... +70 °C										
Weight	with connection cable 2 m Transm.: approx. 53 g, receiv.: approx. 53 g										
	With M 8 plug Transm.: approx. 9 g, receiv.: approx. 9 g										
Housing material	Housing ABS; optics: PC										

- 1) Average service life 100,000 h at $T_U = +25$ °C
- 2) Limit values
- 3) Must be within V_s tolerances
- 4) Without load
- 5) L = light switching, D = dark switching
- 6) With resistive load
- 7) With light/dark ratio 1:1
- 8) Do not bend cable below 0 °C
- 9) Rated voltage 50 V DC
- 10) A = V_s connections reverse-polarity protected
B = Inputs and outputs reverse-polarity protected
C = Interference suppression
- D = Outputs overcurrent and short-circuit protected
- 11) The order no. includes transmitter and receiver

Scanning ranges and operating reserves

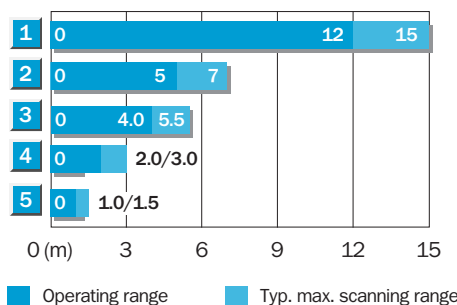

Scanning range reduction when slotted masks are used

1	Without masks/polarizing filter	
2	With polarizing filter tip adapter	
3	With slotted mask, width 2.0 mm	
4	With slotted mask, width 1.0 mm	
5	With slotted mask, width 0.5 mm	

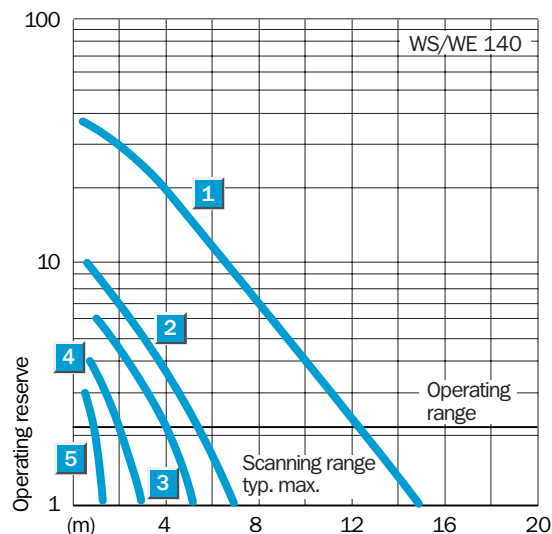

Ordering information

Type	Order no. ¹¹⁾
WS/WE 140-P132	6 012 599
WS/WE 140-P330	6 012 601
WS/WE 140-P430	6 012 602
WS/WE 140-N132	6 012 595
WS/WE 140-N330	6 012 597
WS/WE 140-N430	6 012 598

Dimension illustrations and ordering information

Plastic model for temperatures up to 65 °C

Reflector 32.8 x 8.4 mm *)

Type	Order no.
P 45	5 308 002

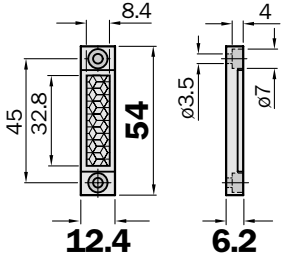

*) Supplied with WL 140

Reflector 80 x 80 mm

Type	Order no.
PL 80 A	1 003 865

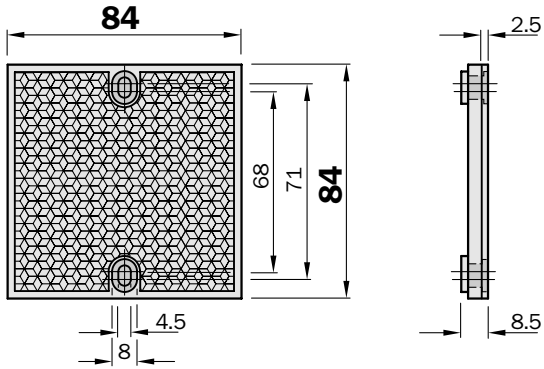

Reflector 47 x 47 mm

Type	Order no.
P 250	5 304 812

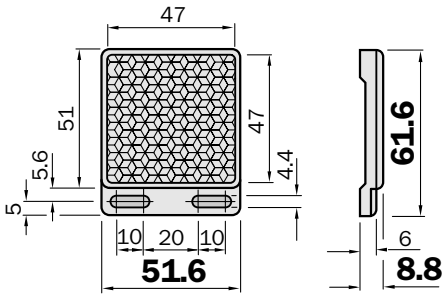

Masks/polarizing filter

Slotted masks for WS/WE 140 *)

Slot width X: 0.5 mm/1.0 mm/2.0 mm

Type	Order no.
BL-140-10	5 308 458

*) Two pieces each

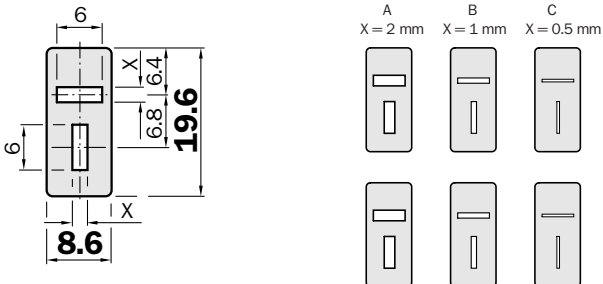

Polarizing filter, vertical for W 140

Type	Order no.	Model
BL-140-POLF	5 308 457	4 pieces, each 2x for X and Y polarizing

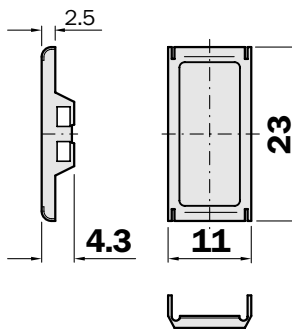

3 pairs with slot widths A, B and C are supplied with equipment.
 Mounting by self-adhesive back.
 Stick mask on red optics body of WS 140 and WE 140.
 For detecting smaller objects or increasing the switching accuracy.
 Only for WS/WE 140.

Changed operating ranges:

- A) Slot width 2.0 mm: SR = 4.0 m
- B) Slot width 1.0 mm: SR = 2.0 m
- C) Slot width 0.5 mm: SR = 1.0 m

Dimension illustrations and ordering information

Mounting bracket

Mounting bracket, horizontal for W 140 *)

Type	Order no.
BEF-W 140-A	5 308 098

Mounting

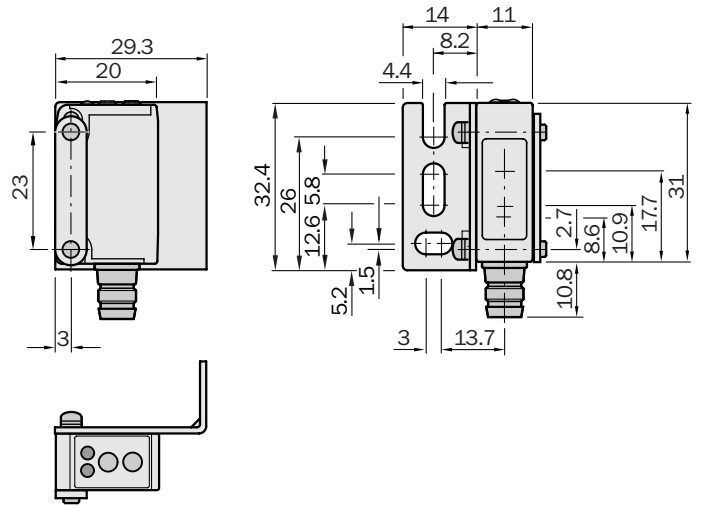
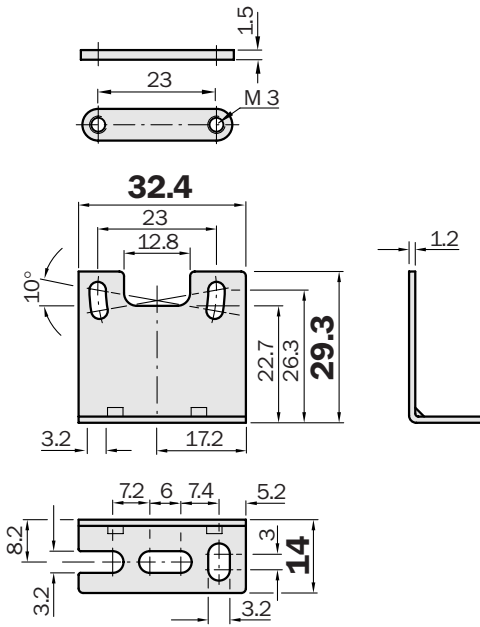

*) Supplied with W 140

Mounting bracket, vertical for W 140 **)

Type	Order no.
BEF-W 140-B	5 308 519

Mounting

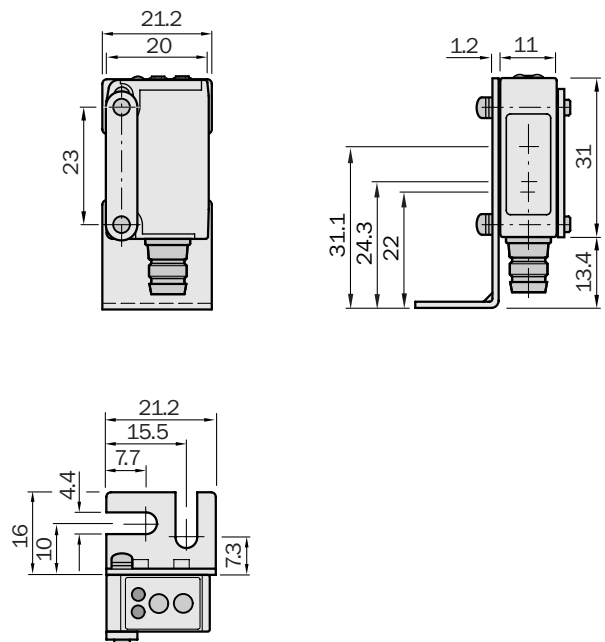
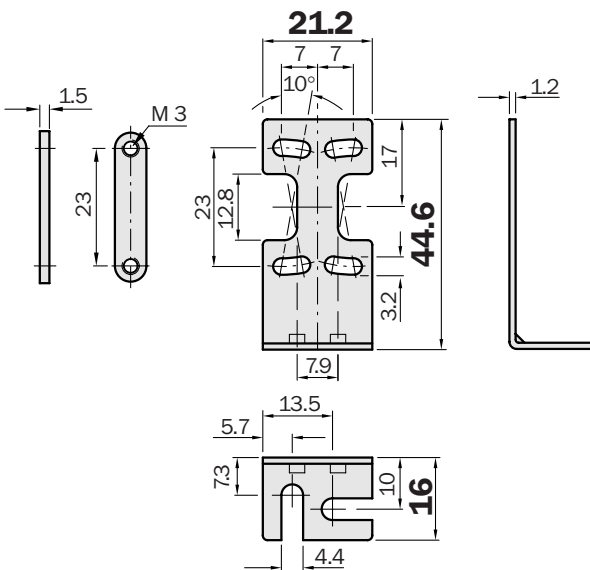

***) Optional. Please order separately.

Dimension illustrations and ordering information

SENSICK circular screwing system, M 8 plug, 3 pin, enclosure rating IP 67

M 8 cable receptacle, 3 pin, straight

Type	Order no.
DOS-0803-G	7 902 077

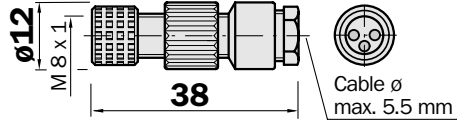

M8 Cable receptacle, 3 pin, angled

Type	Order no.
DOS-0803-W	7 902 078

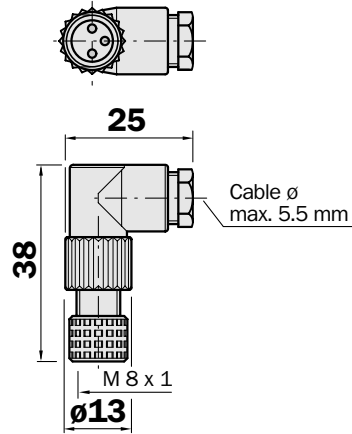

M8 cable receptacle, 3 pin, straight

Cable ϕ 5 mm, 3 x 0.25 mm², PVC coating

Type	Order no.	Cable length
DOL-0803-G02M	6 010 785	2 m

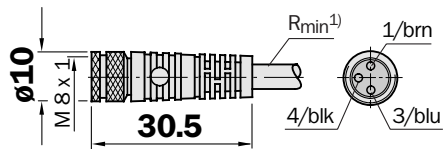

M8 cable receptacle, 3 pin, angled

Cable ϕ 5 mm, 3 x 0.25 mm², PVC coating

Type	Order no.	Cable length
DOL-0803-W02M	6 008 489	2 m

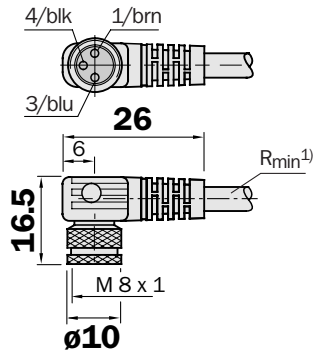

1) Minimum bending radius with dynamic use
 $R_{min} = 20 \times \text{cable diameter}$

Dimension illustrations and ordering information

SENSICK circular screwing system, M 8 plug, 4 pin, enclosure rating IP 67

M 8 cable receptacle, 4 pin, straight

Type	Order no.
DOS-0804-G	6 009 974

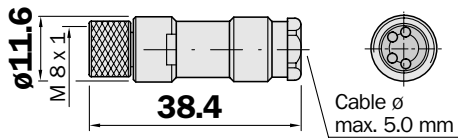

M8 cable receptacle, 4 pin, angled

Type	Order no.
DOS-0804-W	6 009 975

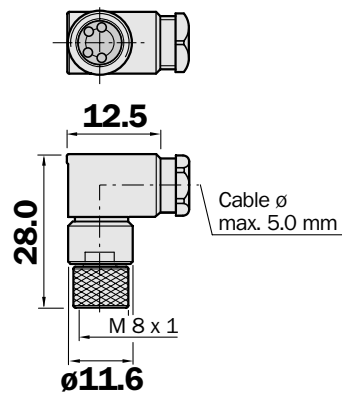

M 8 cable receptacle, 4 pin, straight

Cable \varnothing 5 mm, 4 x 0.25 mm², PVC coating

Type	Order no.	Cable length
DOL-0804-G02M	6 009 870	2 m
DOL-0804-G05M	6 009 872	5 m
DOL-0804-G10M	6 010 754	10 m

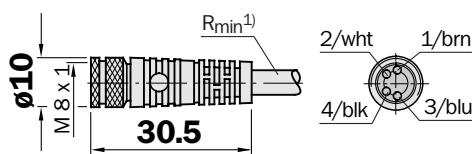

M 8 cable receptacle, 4 pin, angled

Cable \varnothing 5 mm, 4 x 0.25 mm², PVC coating

Type	Order no.	Cable length
DOL-0804-W02M	6 009 871	2 m
DOL-0804-W05M	6 009 873	5 m
DOL-0804-W10M	6 010 755	10 m

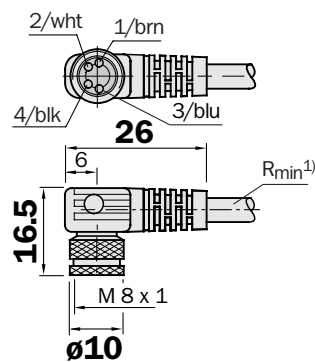

1) Minimum bending radius with dynamic use
 $R_{min} = 20 \times$ cable diameter