

# W 12-2: Fantastic performance – years of experience

 Photoelectric proximity switches, FGS

 Photoelectric proximity switches, BGS

 Photoelectric proximity switches, energetic



insensitivity to ambient light and mutual interference when units are installed close together, are all device standards.

The WL 12 G "glass photoelectric switch" designed for filling systems used in the beverage industry, represents more than just a technical advance. This intelligent sensor needs to be configured just once using the teach-in method and then it is able to adapt its switching threshold to increasing contamination continuously and fully automatically during operation. As a result, transparent objects, e.g. transparent films or filled PET mineral water bottles, can now be detected much more reliably. Continual cleaning and realignment are, therefore, a thing of the past. Monitoring the flow of bottles, and bottle counting, has been made possible while simultaneously minimising maintenance requirements.

 Photoelectric reflex switches

 Through-beam photoelectric switches

 Photoelectric switches with fibre-optic cable

Proximity mode

 Photoelectric switches with fibre-optic cable

Through-beam mode

**T**he W 12-2 series of photoelectric switches is in use all over the world. The key advantage for the user is the wealth of experience gained from the previous W 12 series. The W 12-2 series is backed by years of know-how gained from many thousands of applications.

A sturdy metal housing protects the WT 12-2 photoelectric proximity switch, the WL 12-2 photoelectric reflex switch and the WS/WE 12-2 through-beam photoelectric switch. Rotatable plugs provide flexibility of location and cable installation. Features such as foreground and background suppression, ASI interface, fibre-optic cable versions,

The Teflon-coated version is an added bonus for use in, for example, the beverage industry.

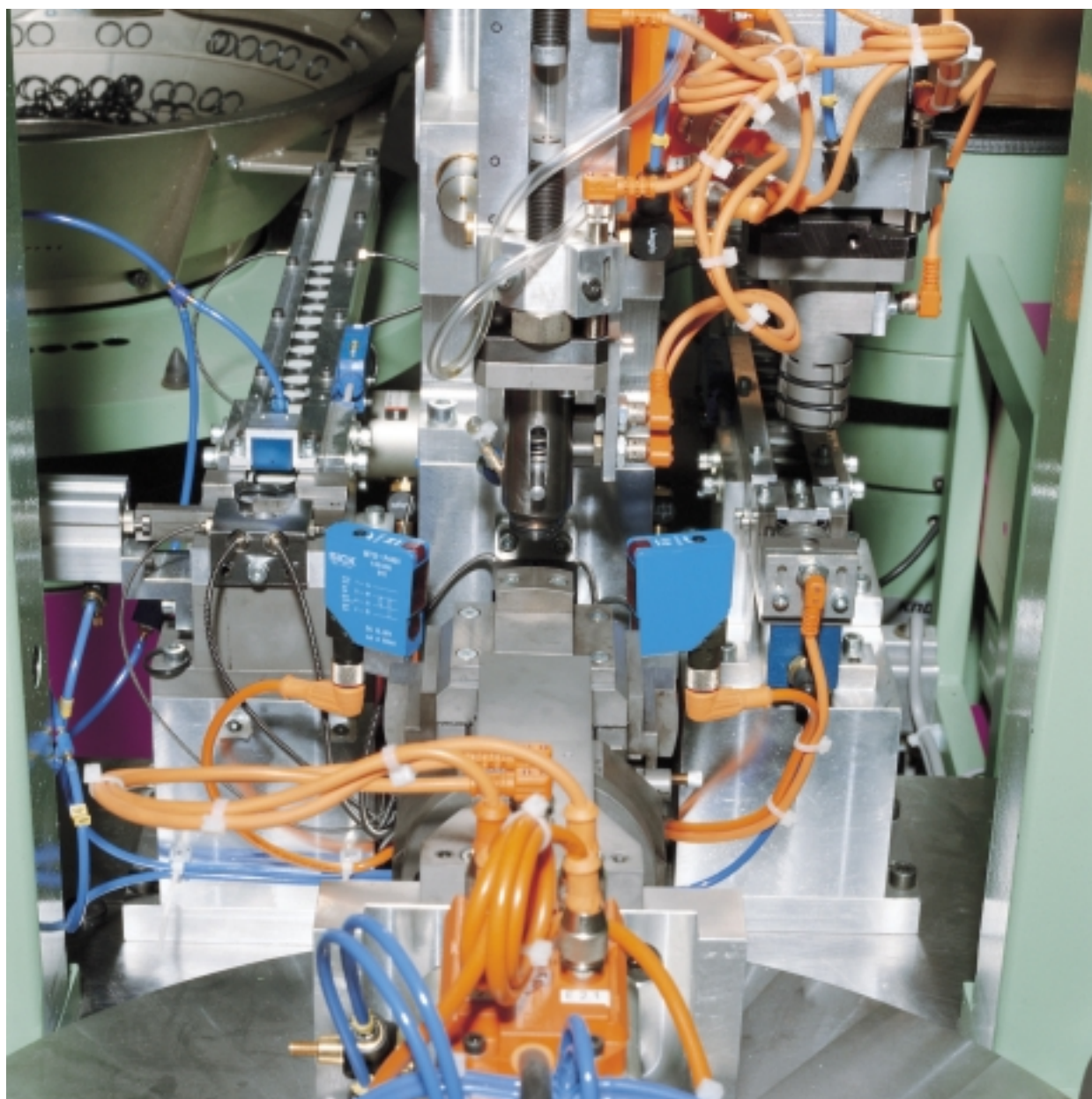

◀ WT 12-2 photoelectric proximity switches used to ensure that sealing rings are supplied smoothly in a fully automatic system for assembling low-power motors.



▲ Five-pack instead of six-pack: WT 12-2 photoelectric proximity switches with background suppression detecting gaps in the flow of bottles in an automatic loader.

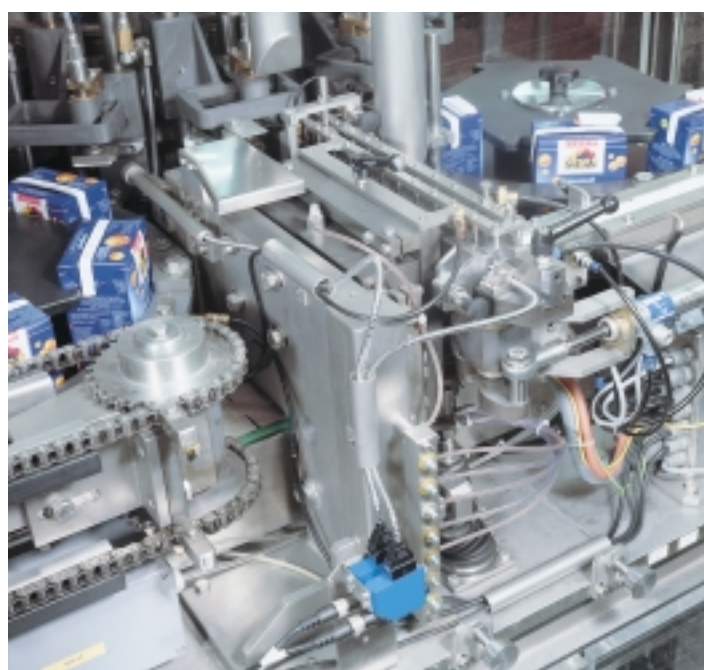

▲ Direct object detection using fibre-optic cables: WLL 12 photoelectric reflex switches signalling the presence of the spout in each drink container.

**Scanning distance**  
**35...100 mm**

Photoelectric proximity switches

- Red light
- Insensitive to ambient light sources
- M 12 plug rotatable by 90°, or 2 m cable
- Adjustable foreground suppression and scanning distance

**Dimensional drawing**

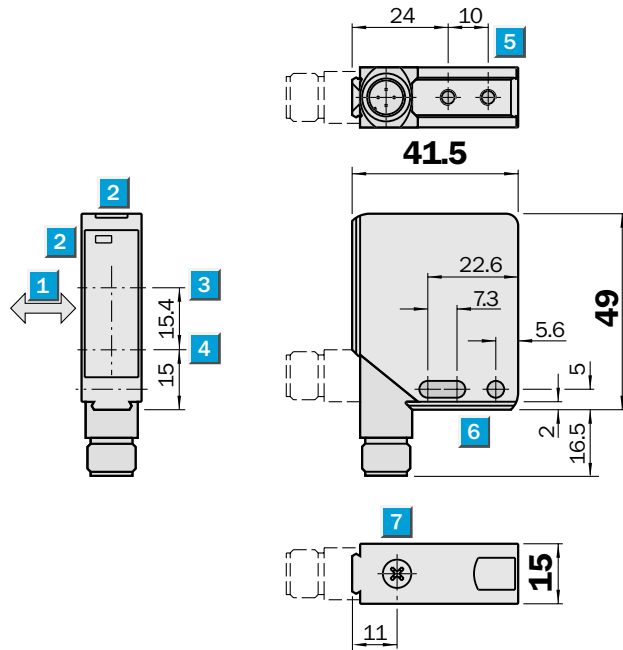

**Adjustments possible**

WT 12-2P 440	WT 12-2N 440
WT 12-2P 140	WT 12-2N 140

- 1 Standard direction of the material being scanned
- 2 LED signal strength indicator
- 3 Receiver's optical axis
- 4 Transmitter's optical axis
- 5 M 4 threaded mounting hole – 4 mm deep
- 6 Mounting holes  $\varnothing$  4.2 mm
- 7 Scanning distance adjustment



**Connection types**

WT 12-2P 140	WT 12-2P 440
WT 12-2N 140	WT 12-2N 440

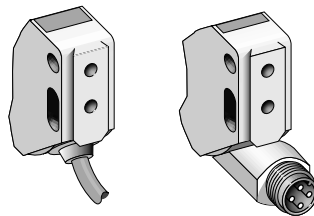

4 x 0.25 mm <sup>2</sup>	4-pin, M 12
--------------------------	-------------

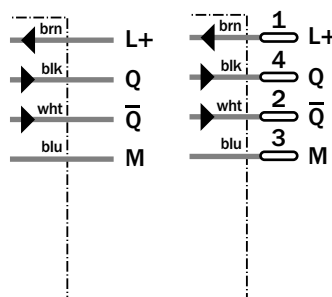

Accessories	page
Cable receptacles	496
Mounting brackets	510
Clamps*	510

\* 2 pieces included with delivery

Technical data		WT 12-2	P 440	P 140	N 440	N 140
<b>Scanning distance</b>	35...100 mm, adjustable					
<b>Light source<sup>1)</sup>, light type</b>	LED, red light					
Light spot size	3 x 3 mm at 60 mm					
<b>Supply voltage <math>V_S</math></b>	10...30 V DC <sup>2)</sup>					
Ripple <sup>3)</sup>	$\leq 5 V_{SS}$					
Current consumption <sup>4)</sup>	$\leq 30$ mA					
	$\leq 40$ mA					
<b>Switching outputs</b>	PNP, Q and $\bar{Q}$					
	NPN, Q and $\bar{Q}$					
Output current $I_A$ max.	$\leq 100$ mA					
Response time <sup>5)</sup>	$\leq 330$ $\mu$ s					
Max. switching frequency <sup>6)</sup>	1500 Hz					
<b>Connection types</b>	Cable <sup>7)</sup> , 2 m					
	4-pin, M 12 plug					
<b>VDE protection class<sup>8)</sup></b>	<input type="checkbox"/>					
<b>Circuit protection<sup>9)</sup></b>	A, B, C					
<b>Enclosure rating</b>	IP 67					
<b>Ambient temperature <math>T_A</math></b>	Operation -40 °C...+60 °C					
	Storage -40 °C...+75 °C					
<b>Weight</b>	With plug: 120 g					
	With cable: 200 g					
<b>Housing material</b>	Zinc die-cast housing					

- 1) Average service life 100,000 h at  $T_A = +25$  °C
- 2) Limit values
- 3) May not exceed or fall short of  $V_S$  tolerances

- 4) Without load
- 5) Signal transit time with resistive load
- 6) With light/dark ratio 1:1
- 7) Do not bend below 0 °C
- 8) Reference voltage 50 V DC

- 9) A =  $V_S$  connections reverse-polarity protected
- B = Output Q and  $\bar{Q}$  short-circuit protected
- C = Interference pulse suppression

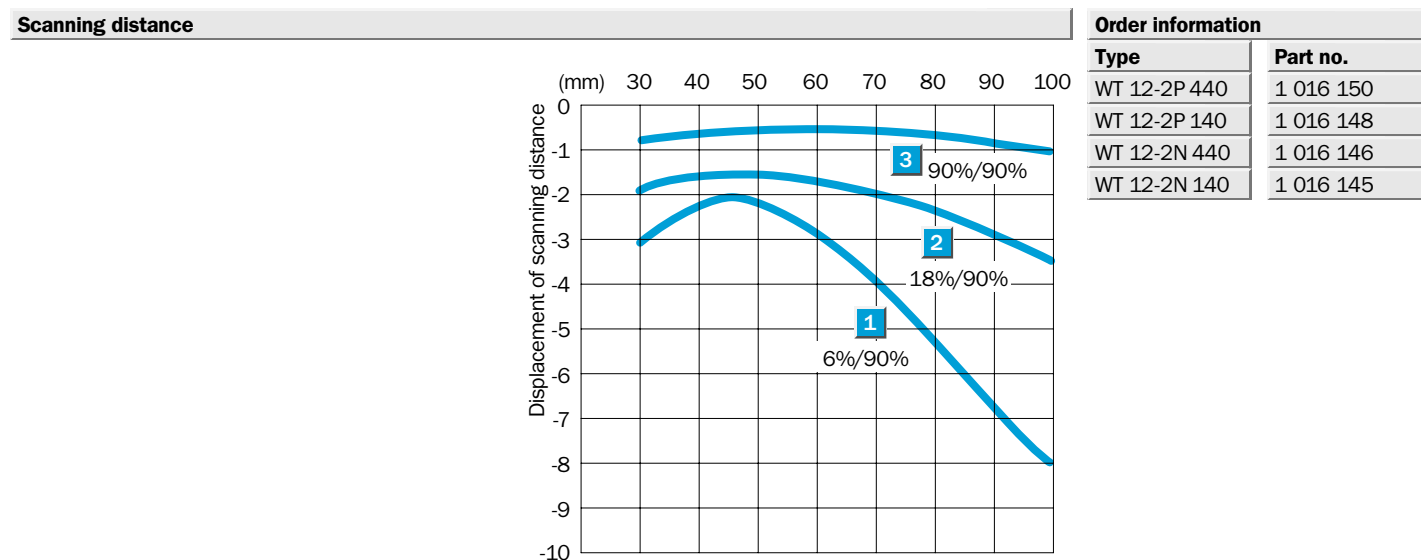



**Scanning distance**  
**20...250 mm**

Photoelectric proximity switches

- Red light
- Insensitive to ambient light sources
- M 12 plug rotatable by 90°, or 2 m cable
- Adjustable background suppression

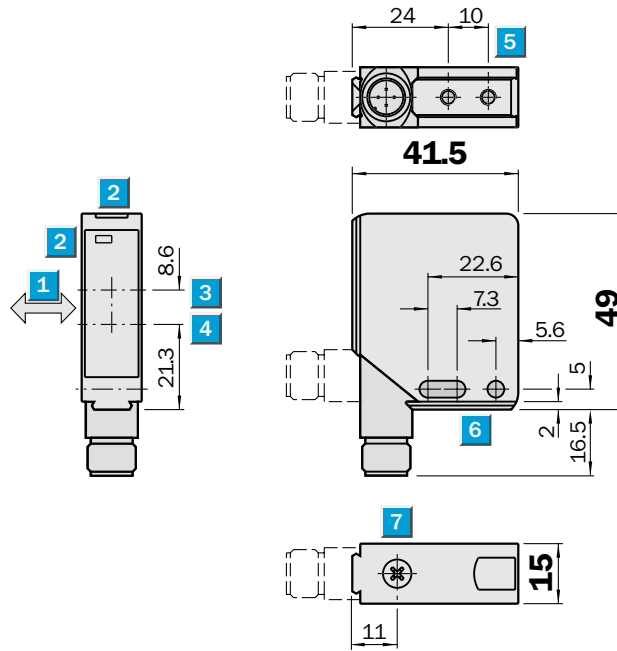
**Dimensional drawing**



**Adjustments possible**

WT 12-2P 430	WT 12-2N 430
WT 12-2P 130	WT 12-2N 130

- 1 Standard direction of the material being scanned
- 2 LED signal strength indicator
- 3 Receiver's optical axis
- 4 Transmitter's optical axis
- 5 M 4 threaded mounting hole – 4 mm deep
- 6 Mounting holes  $\varnothing$  4.2 mm
- 7 Scanning distance adjustment

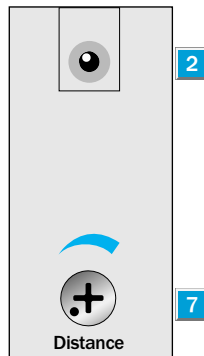

**Connection types**

WT 12-2P 130	WT 12-2N 430
WT 12-2N 130	WT 12-2P 430

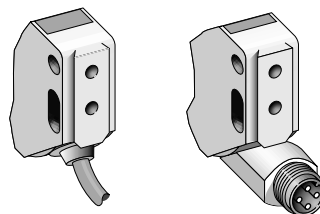

4 x 0.25 mm <sup>2</sup>	4-pin, M 12
--------------------------	-------------

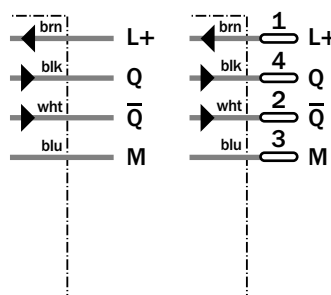

Accessories	page
Cable receptacles	496
Mounting brackets	510
Clamps*	510

\* 2 pieces included with delivery

Technical data		WT 12-2	P 430	P 130	N 430	N 130
<b>Scanning distance</b>	20...250 mm, adjustable					
<b>Light source<sup>1)</sup>, light type</b>	LED, red light					
Light spot diameter	10 mm at 200 mm					
<b>Supply voltage <math>V_S</math></b>	10...30 V DC <sup>2)</sup>					
Ripple <sup>3)</sup>	$\leq 5 V_{SS}$					
Current consumption <sup>4)</sup>	$\leq 30$ mA					
	$\leq 40$ mA					
<b>Switching outputs</b>	PNP, Q and $\bar{Q}$					
	NPN, Q and $\bar{Q}$					
Output current $I_A$ max.	$\leq 100$ mA					
Response time <sup>5)</sup>	$\leq 330$ $\mu$ s					
Max. switching frequency <sup>6)</sup>	1500 Hz					
<b>Connection types</b>	Cable <sup>7)</sup> , 2 m					
	4-pin, M 12 plug					
<b>VDE protection class<sup>8)</sup></b>	<input type="checkbox"/>					
<b>Circuit protection<sup>9)</sup></b>	A, B, C					
<b>Enclosure rating</b>	IP 67					
<b>Ambient temperature <math>T_A</math></b>	Operation $-40$ °C...+60 °C					
	Storage $-40$ °C...+75 °C					
<b>Weight</b>	With plug: 120 g					
	With cable: 200 g					
<b>Housing material</b>	Zinc die-cast housing					

1) Average service life 100,000 h at  $T_A = +25$  °C  
 2) Limit values

3) May not exceed or fall short of  $V_S$  tolerances  
 4) Without load  
 5) Signal transit time with resistive load

6) With light/dark ratio 1:1  
 7) 2 m long, PVC, 5 mm  $\phi$ ; do not bend below 0 °C  
 8) Reference voltage 50 V DC

9) A =  $V_S$  connections reverse-polarity protected  
 B = Output Q and  $\bar{Q}$  short-circuit protected  
 C = Interference pulse suppression

Scanning distance		Order information										
		<table border="1"> <thead> <tr> <th>Type</th> <th>Part no.</th> </tr> </thead> <tbody> <tr> <td>WT 12-2P 430</td> <td>1 016 134</td> </tr> <tr> <td>WT 12-2P 130</td> <td>1 016 129</td> </tr> <tr> <td>WT 12-2N 430</td> <td>1 016 125</td> </tr> <tr> <td>WT 12-2N 130</td> <td>1 016 122</td> </tr> </tbody> </table>	Type	Part no.	WT 12-2P 430	1 016 134	WT 12-2P 130	1 016 129	WT 12-2N 430	1 016 125	WT 12-2N 130	1 016 122
		Type	Part no.									
		WT 12-2P 430	1 016 134									
WT 12-2P 130	1 016 129											
WT 12-2N 430	1 016 125											
WT 12-2N 130	1 016 122											
<table border="1"> <tbody> <tr> <td>1</td> <td>Scanning distance on black, 6 % remission</td> </tr> <tr> <td>2</td> <td>Scanning distance on grey, 18 % remission</td> </tr> <tr> <td>3</td> <td>Scanning distance on white, 90 % remission</td> </tr> </tbody> </table>	1	Scanning distance on black, 6 % remission	2	Scanning distance on grey, 18 % remission	3	Scanning distance on white, 90 % remission						
1	Scanning distance on black, 6 % remission											
2	Scanning distance on grey, 18 % remission											
3	Scanning distance on white, 90 % remission											



**Scanning distance**  
 20...250 mm

Photoelectric proximity switches

- Red light
- Insensitive to ambient light sources
- M 12 plug rotatable by 90°
- With integrated ASI chip
- Adjustable background suppression

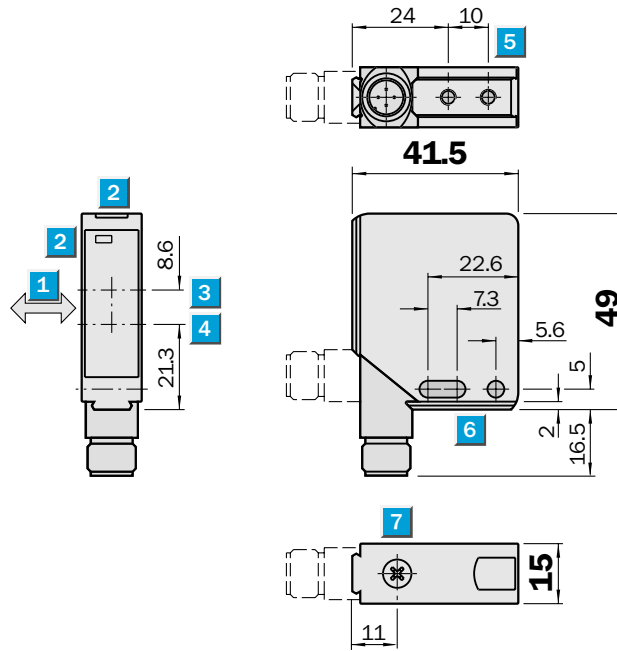

**Dimensional drawing**



**Adjustments possible**

WT 12-2Z 430

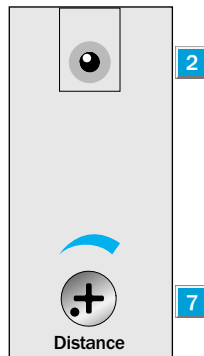

- 1 Standard direction of the material being scanned
- 2 LED signal strength indicator
- 3 Receiver's optical axis
- 4 Transmitter's optical axis
- 5 M 4 threaded mounting hole – 4 mm deep
- 6 Mounting holes  $\varnothing$  4.2 mm
- 7 Scanning distance adjustment

**Connection type**

WT 12-2Z 430

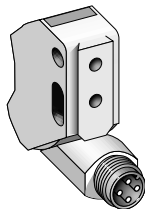

4-pin, M 12

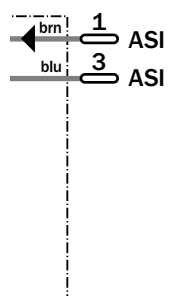

Accessories	page
Cable receptacles	496
Mounting brackets	510
Clamps*	510
ASI	574

\* 2 pieces included with delivery

**Technical data** WT 12-2 Z 430

<b>Scanning distance</b>	20...250 mm, adjustable	
<b>Light source<sup>1)</sup>, light type</b>	LED, red light	
Light spot diameter	10 mm at 200 mm	
<b>Supply voltage V<sub>S</sub></b>	26.5...31.5 V DC <sup>2)</sup>	
Current consumption <sup>3)</sup>	≤ 35 mA	
Response time <sup>4)</sup>	≤ 330 μs	
Max. switching frequency <sup>5)</sup>	1500 Hz	
<b>Connection type</b>	4-pin, M 12 plug	
<b>VDE protection class<sup>6)</sup></b>	□	
<b>Circuit protection<sup>7)</sup></b>	A, B, C	
<b>Enclosure rating</b>	IP 67	
<b>Ambient temperature T<sub>A</sub></b>	Operation - 25 °C...+ 60 °C Storage - 40 °C...+ 75 °C	
<b>Weight</b>	With plug: 120 g	
<b>Housing material</b>	Zinc die-cast housing	

- 1) Average service life 100,000 h at T<sub>A</sub> = + 25 °C
- 2) Limit values
- 3) Without load
- 4) Signal transit time with resistive load
- 5) With light/dark ratio 1:1
- 6) Reference voltage 50 V DC
- 7) A = V<sub>S</sub> connections reverse-polarity protected  
B = Output Q and  $\bar{Q}$  short-circuit protected  
C = Interference pulse suppression

Assignment of data bits (Host level)				Assignment of parameter bits (Host level)			
D <sub>0</sub>	Switching state	0 No reflection 1 Reflection	Input	P <sub>0</sub> *	NC	0 1	Parameter
D <sub>1</sub>	Alarm	0 active 1 inactive	Input	P <sub>1</sub> *	Light/dark selector	0 Dark-switching 1 Light-switching	Parameter
D <sub>2</sub>	NC	0 1	Input	P <sub>2</sub> *	NC	0 1	Parameter
D <sub>3</sub> *	Test function	0 Sender ON 1 Sender OFF	Output	P <sub>3</sub> *	NC	0 1	Parameter

\* Default setting = 1

**Scanning distance** **Order information**

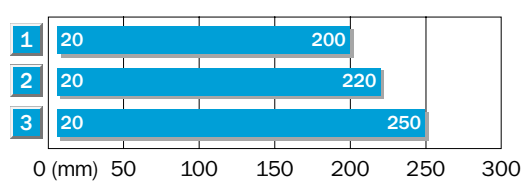

- 1 Scanning distance on black, 6 % remission
- 2 Scanning distance on grey, 18 % remission
- 3 Scanning distance on white, 90 % remission

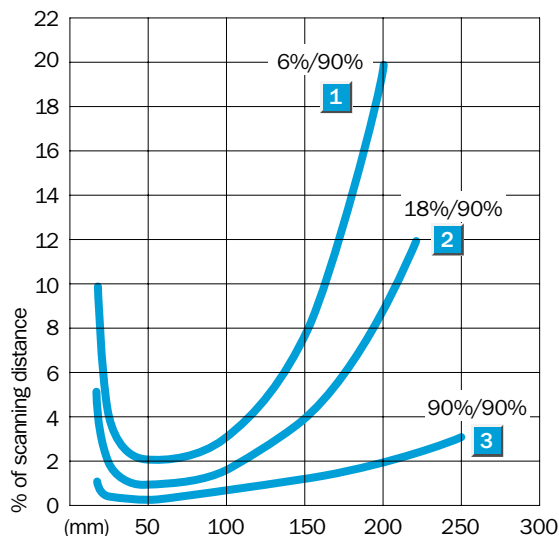

<b>Type</b>	<b>Part no.</b>
WT 12-2Z 430	1 016 136





**Scanning distance**  
**20...250 mm**

Photoelectric proximity switches

- Infrared
- Insensitive to ambient light sources
- M 12 plug rotatable by 90°, or 2 m cable
- Adjustable background suppression

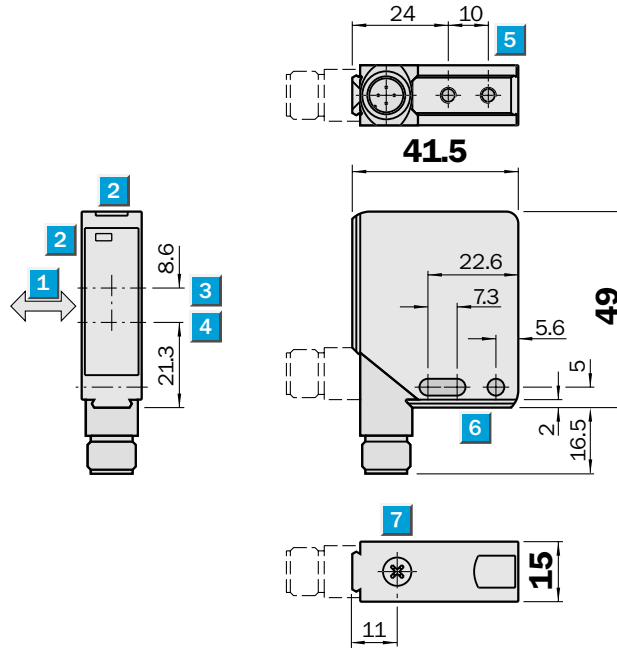
**Dimensional drawing**



**Adjustments possible**

WT 12-2P 410	WT 12-2N 410
WT 12-2P 110	WT 12-2N 110

- 1 Standard direction of the material being scanned
- 2 LED signal strength indicator
- 3 Receiver's optical axis
- 4 Transmitter's optical axis
- 5 M 4 threaded mounting hole – 4 mm deep
- 6 Mounting holes  $\varnothing$  4.2 mm
- 7 Scanning distance adjustment

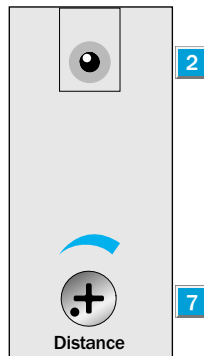

**Connection types**

WT 12-2P 110	WT 12-2P 410
WT 12-2N 110	WT 12-2N 410

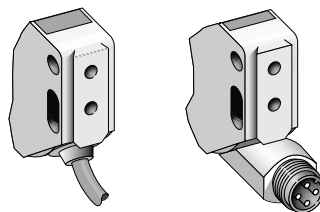

4 x 0.25 mm<sup>2</sup>      4-pin, M 12

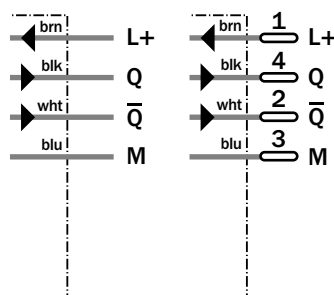

Accessories	page
Cable receptacles	496
Mounting brackets	510
Clamps*	510

\* 2 pieces included with delivery

Technical data		WT 12-2	P 410	P 110	N 410	N 110
<b>Scanning distance</b>	20...250 mm, adjustable					
<b>Light source<sup>1)</sup>, light type</b>	LED, infrared light					
Light spot diameter	10 mm at 200 mm					
<b>Supply voltage <math>V_S</math></b>	10...30 V DC <sup>2)</sup>					
Ripple <sup>3)</sup>	$\leq 5 V_{SS}$					
Current consumption <sup>4)</sup>	$\leq 40$ mA					
	$\leq 50$ mA					
<b>Switching outputs</b>	PNP, Q and $\bar{Q}$					
	NPN, Q and $\bar{Q}$					
Output current $I_A$ max.	$\leq 100$ mA					
Response time <sup>5)</sup>	$\leq 330 \mu s$					
Max. switching frequency <sup>6)</sup>	1500 Hz					
<b>Connection types</b>	Cable <sup>7)</sup> , 2 m					
	4-pin, M 12 plug					
<b>VDE protection class<sup>8)</sup></b>	<input type="checkbox"/>					
<b>Circuit protection<sup>9)</sup></b>	A, B, C					
<b>Enclosure rating</b>	IP 67					
<b>Ambient temperature <math>T_A</math></b>	Operation $-40 \text{ }^\circ\text{C} \dots +60 \text{ }^\circ\text{C}$					
	Storage $-40 \text{ }^\circ\text{C} \dots +75 \text{ }^\circ\text{C}$					
<b>Weight</b>	With plug: 120 g					
	With cable: 200 g					
<b>Housing material</b>	Zinc die-cast housing					

1) Average service life 100,000 h at  $T_A = +25 \text{ }^\circ\text{C}$   
 2) Limit values

3) May not exceed or fall short of  $V_S$  tolerances  
 4) Without load  
 5) Signal transit time with resistive load

6) With light/dark ratio 1:1  
 7) 2 m long, PVC, 5 mm  $\phi$ ; do not bend below  $0 \text{ }^\circ\text{C}$   
 8) Reference voltage 50 V DC; 250 V AC

9) A =  $V_S$  connections reverse-polarity protected  
 B = Output Q and  $\bar{Q}$  short-circuit protected  
 C = Interference pulse suppression

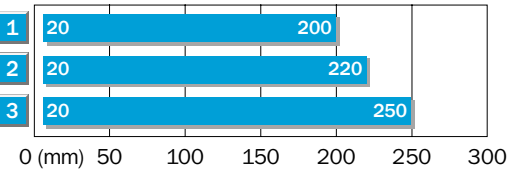
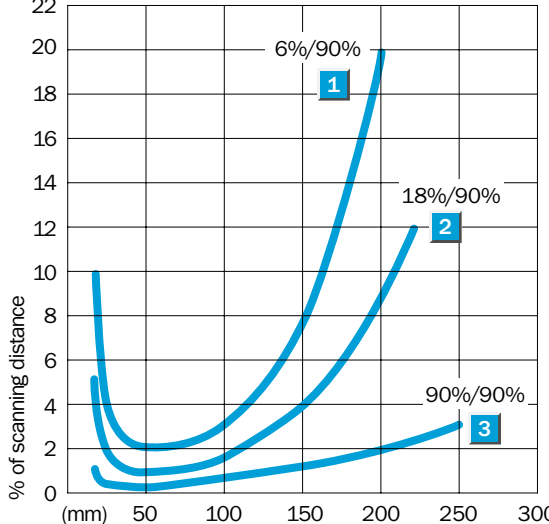
Scanning distance		Order information									
	<table border="1"> <thead> <tr> <th>Type</th> <th>Part no.</th> </tr> </thead> <tbody> <tr> <td>WT 12-2P 410</td> <td>1 016 131</td> </tr> <tr> <td>WT 12-2P 110</td> <td>1 016 126</td> </tr> <tr> <td>WT 12-2N 410</td> <td>1 016 124</td> </tr> <tr> <td>WT 12-2N 110</td> <td>1 016 118</td> </tr> </tbody> </table>	Type	Part no.	WT 12-2P 410	1 016 131	WT 12-2P 110	1 016 126	WT 12-2N 410	1 016 124	WT 12-2N 110	1 016 118
	Type	Part no.									
	WT 12-2P 410	1 016 131									
WT 12-2P 110	1 016 126										
WT 12-2N 410	1 016 124										
WT 12-2N 110	1 016 118										
											
<table border="1"> <tbody> <tr> <td>1</td> <td>Scanning distance on black, 6 % remission</td> </tr> <tr> <td>2</td> <td>Scanning distance on grey, 18 % remission</td> </tr> <tr> <td>3</td> <td>Scanning distance on white, 90 % remission</td> </tr> </tbody> </table>	1	Scanning distance on black, 6 % remission	2	Scanning distance on grey, 18 % remission	3	Scanning distance on white, 90 % remission					
1	Scanning distance on black, 6 % remission										
2	Scanning distance on grey, 18 % remission										
3	Scanning distance on white, 90 % remission										

**Scanning distance**  
**80...800 mm**

Photoelectric proximity switches

- Red light
- Insensitive to ambient light sources
- M 12 plug rotatable by 90°, or 2 m cable
- Energetic proximity switch, adjustable

**Dimensional drawing**

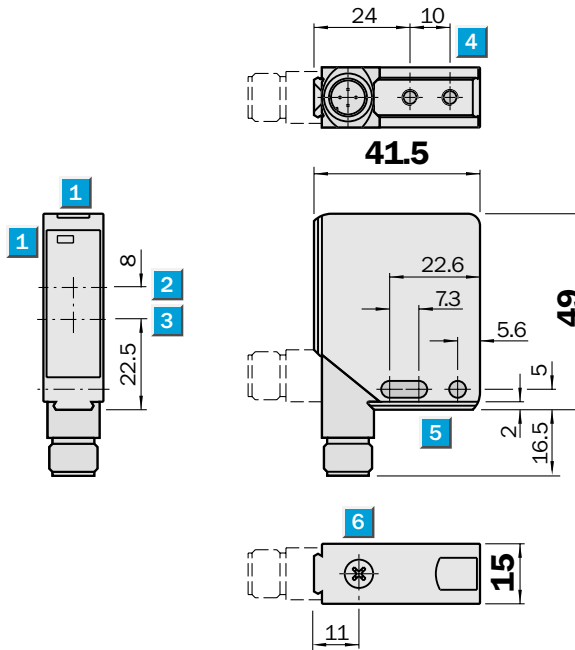

**Adjustments possible**

WT 12-2P 450	WT 12-2N 450
WT 12-2P 150	WT 12-2N 150

- 1 LED signal strength indicator
- 2 Receiver's optical axis
- 3 Transmitter's optical axis
- 4 M 4 threaded mounting hole – 4 mm deep
- 5 Mounting holes  $\varnothing$  4.2 mm
- 6 Scanning distance adjustment

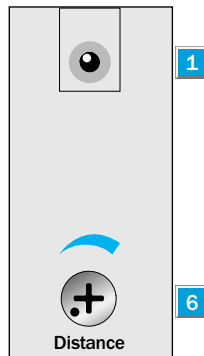

**Connection types**

WT 12-2P 150	WT 12-2P 450
WT 12-2N 150	WT 12-2N 450

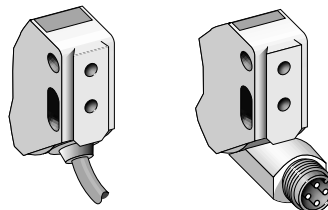

4 x 0.25 mm<sup>2</sup>

4-pin, M 12

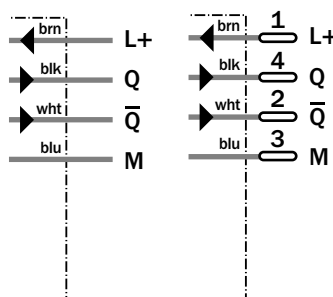

Accessories	page
Cable receptacles	496
Mounting brackets	510
Clamps*	510

\* 2 pieces included with delivery

Technical data		WT 12-2	P 450	P 150	N 450	N 150
<b>Scanning distance</b>	80...800 mm, adjustable					
<b>Light source<sup>1)</sup>, light type</b>	LED, red light					
Light spot diameter	30 mm at 600 mm					
<b>Supply voltage <math>V_S</math></b>	10...30 V DC <sup>2)</sup>					
Ripple <sup>3)</sup>	$\leq 5 V_{SS}$					
Current consumption <sup>4)</sup>	$\leq 30$ mA					
	$\leq 40$ mA					
<b>Switching outputs</b>	PNP, Q and $\bar{Q}$					
	NPN, Q and $\bar{Q}$					
Output current $I_A$ max.	$\leq 100$ mA					
Response time <sup>5)</sup>	$\leq 330$ $\mu$ s					
Max. switching frequency <sup>6)</sup>	1500 Hz					
<b>Connection types</b>	Cable <sup>7)</sup> , 2 m					
	4-pin, M 12 plug					
<b>VDE protection class<sup>8)</sup></b>	<input type="checkbox"/>					
<b>Circuit protection<sup>9)</sup></b>	A, B, C					
<b>Enclosure rating</b>	IP 67					
<b>Ambient temperature <math>T_A</math></b>	Operation $-40$ °C... $+60$ °C					
	Storage $-40$ °C... $+75$ °C					
<b>Weight</b>	With plug: 120 g					
	With cable: 200 g					
<b>Housing material</b>	Zinc die-cast housing					

- 1) Average service life 100,000 h at  $T_A = +25$  °C
- 2) Limit values
- 3) May not exceed or fall short of  $V_S$  tolerances

- 4) Without load
- 5) Signal transit time with resistive load
- 6) With light/dark ratio 1:1
- 7) Do not bend below 0 °C
- 8) Reference voltage 50 V DC

- 9) A =  $V_S$  connections reverse-polarity protected
- B = Output Q and  $\bar{Q}$  short-circuit protected
- C = Interference pulse suppression

Scanning distance		Order information										
<p>1) Scanning distance on grey, 18 % remission</p> <p>2) Scanning distance on white, 90 % remission</p>		<table border="1" style="width: 100%; border-collapse: collapse;"> <thead> <tr> <th>Type</th> <th>Part no.</th> </tr> </thead> <tbody> <tr> <td>WT 12-2P 450</td> <td>1 016 142</td> </tr> <tr> <td>WT 12-2P 150</td> <td>1 016 140</td> </tr> <tr> <td>WT 12-2N 450</td> <td>1 016 139</td> </tr> <tr> <td>WT 12-2N 150</td> <td>1 016 138</td> </tr> </tbody> </table>	Type	Part no.	WT 12-2P 450	1 016 142	WT 12-2P 150	1 016 140	WT 12-2N 450	1 016 139	WT 12-2N 150	1 016 138
Type	Part no.											
WT 12-2P 450	1 016 142											
WT 12-2P 150	1 016 140											
WT 12-2N 450	1 016 139											
WT 12-2N 150	1 016 138											



**Scanning range**  
**7 m**

Photoelectric reflex switches

- Red light
- Insensitive to ambient light sources
- M 12 plug rotatable by 90°, or 2 m cable
- Adjustable sensitivity

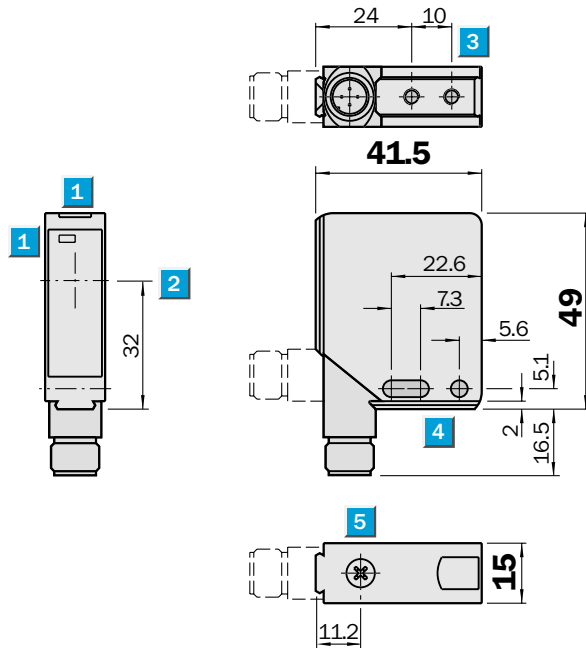

**Dimensional drawing**



**Adjustments possible**

WL 12-2P 430	WL 12-2N 430
WL 12-2P 130	WL 12-2N 130
WL 12-2P 420	WL 12-2N 420
WL 12-2P 120	WL 12-2N 120

- 1** LED signal strength indicator
- 2** Centre of optical axis
- 3** M 4 threaded mounting hole – 4 mm deep
- 4** Mounting holes  $\phi$  4.2 mm
- 5** Sensitivity adjustment

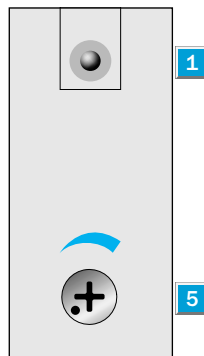

**Connection types**

WL 12-2P 130	WL 12-2N 130	WL 12-2P 430	WL 12-2N 430
WL 12-2P 120	WL 12-2N 120	WL 12-2P 420	WL 12-2N 420

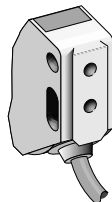

4 x 0.25 mm<sup>2</sup>

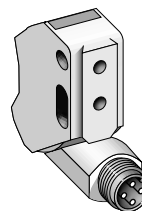
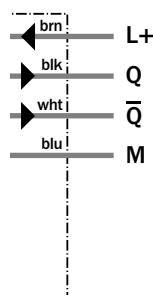

4-pin, M 12

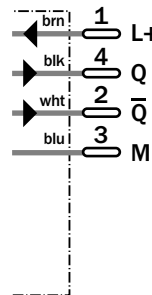

Accessories	page
Cable receptacles	496
Mounting brackets	510
Clamps*	510
Reflectors	520

\* 2 pieces included with delivery

<b>Technical data</b>	WL 12-2	P 430	P 130	P 420	P 120	N 430	N 130	N 420	N 120		
-----------------------	---------	-------	-------	-------	-------	-------	-------	-------	-------	--	--

**Scanning range**

max. typical/on reflector, $f = \infty$	7 m										
max. typical/on reflector, $f = 90$ mm	2 m										
Sensitivity	adjustable										
<b>Light source<sup>1)</sup>, light type</b>	LED, red light										
Light spot diameter	80 mm at a distance of 3 m										
	2 mm at a distance of 90 mm										
<b>Supply voltage <math>V_S</math></b>	10...30 V DC <sup>2)</sup>										
Ripple <sup>3)</sup>	$\leq 5 V_{SS}$										
Current consumption <sup>4)</sup>	$\leq 30$ mA										
	$\leq 40$ mA										

**Switching outputs**

	PNP, Q and $\bar{Q}$										
	NPN, Q and $\bar{Q}$										
Output current $I_A$ max.	$\leq 100$ mA										
Response time <sup>5)</sup>	$\leq 330$ $\mu$ s										
Max. switching frequency <sup>6)</sup>	1500 Hz										

**Connection types**

	Cable <sup>7)</sup> , 2 m										
	4-pin, M 12 plug										

**VDE protection class<sup>8)</sup>**

	<input type="checkbox"/>										
--	--------------------------	--	--	--	--	--	--	--	--	--	--

**Circuit protection<sup>9)</sup>**

	A, B, C										
--	---------	--	--	--	--	--	--	--	--	--	--

**Enclosure rating**

	IP 67										
--	-------	--	--	--	--	--	--	--	--	--	--

**Ambient temperature  $T_A$**

	Operation $-40$ °C... $+60$ °C										
	Storage $-40$ °C... $+75$ °C										

**Weight**

	With plug: 120 g										
	With cable: 200 g										

**Polarising filter**

<b>Housing material</b>	Zinc die-cast housing										
-------------------------	-----------------------	--	--	--	--	--	--	--	--	--	--

- 1) Average service life 100,000 h at  $T_A = +25$  °C
- 2) Limit values
- 3) May not exceed or fall short of  $V_S$  tolerances
- 4) Without load
- 5) Signal transit time with resistive load
- 6) With light/dark ratio 1:1
- 7) Do not bend below 0 °C
- 8) Reference voltage 50 V DC
- 9) A =  $V_S$  connections reverse-polarity protected  
 B = Output Q and  $\bar{Q}$  short-circuit protected  
 C = Interference pulse suppression

**Operating range and operating reserve**

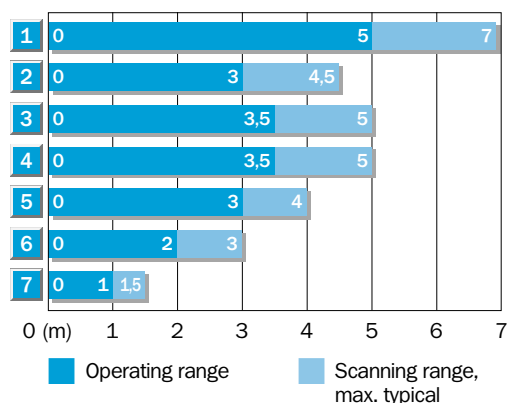

Reflector type	Operating range	
1	PL 80 A	0...5.0 m
2	C 110	0...3.0 m
3	PL 50 A	0...3.5 m
4	PL 40 A	0...3.5 m
5	PL 30 A	0...3.0 m
6	PL 20 A	0...3.0 m
7	Reflective tape	0...1.0 m

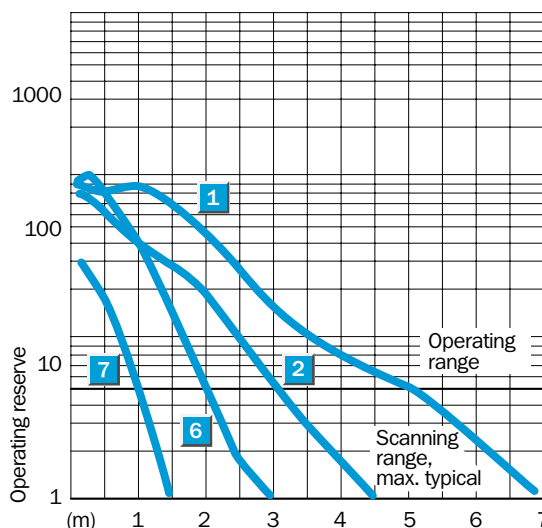

**Order information**

Type	Part no.
WL 12-2P 430	1 016 102
WL 12-2P 130	1 016 096
WL 12-2P 420	1 016 101
WL 12-2P 120	1 016 095
WL 12-2N 430	1 016 092
WL 12-2N 130	1 016 085
WL 12-2N 420	1 016 091
WL 12-2N 120	1 016 084



**Scanning range**  
**7 m**

Photoelectric reflex switches

- Red light
- Insensitive to ambient light sources
- M 12 plug rotatable by 90°
- Integrated ASI chip

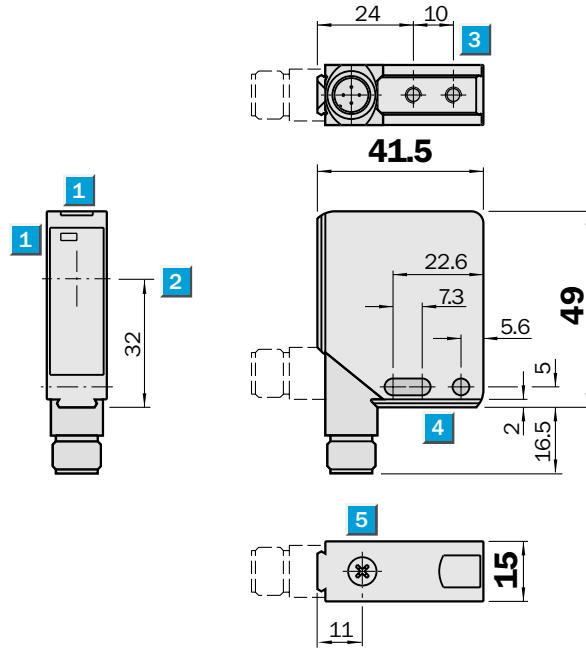

**Dimensional drawing**



**Adjustments possible**

WL 12-2Z 430

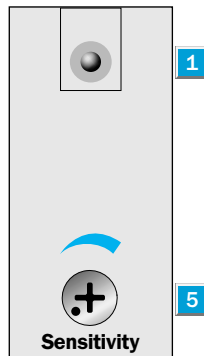

- 1 LED signal strength indicator
- 2 Centre of optical axis
- 3 M 4 threaded mounting hole – 4 mm deep
- 4 Mounting holes  $\varnothing$  4.2 mm
- 5 Sensitivity adjustment

**Connection type**

WL 12-2Z 430

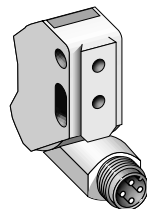

4-pin, M 12

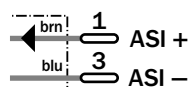

Accessories	page
Cable receptacles	496
Mounting brackets	510
Clamps*	510
Reflectors	520
ASI	574

\* 2 pieces included with delivery

<b>Technical data</b>	WL 12-2	Z 430													
-----------------------	---------	-------	--	--	--	--	--	--	--	--	--	--	--	--	--

**Scanning range**

max. typical/on reflector	7 m/PL 80 A	
Sensitivity	adjustable	
<b>Light source<sup>1)</sup>, light type</b>	LED, red light	
Light spot diameter	80 mm at 3 m	
<b>Supply voltage V<sub>S</sub></b>	26.5...31.6 V DC <sup>2)</sup>	
Ripple <sup>3)</sup>	≤ 35 mA	
Response time <sup>4)</sup>	≤ 330 μs	
Max. switching frequency <sup>5)</sup>	1500 Hz	
<b>Connection type</b>	M 12 plug, 4-pin	
<b>VDE protection class<sup>6)</sup></b>	□	
<b>Circuit protection<sup>7)</sup></b>	A, C	
<b>Enclosure rating</b>	IP 67	
<b>Ambient temperature T<sub>A</sub></b>	Operation - 25 °C...+ 60 °C Storage - 40 °C...+ 75 °C	
<b>Weight</b>	With plug: 120 g	
<b>Polarising filter</b>		
<b>Housing material</b>	Zinc die-cast housing	

- 1) Average service life 100,000 h at T<sub>A</sub> = + 25 °C
- 2) Limit values
- 3) Without load

- 4) Signal transit time with resistive load
- 5) With light/dark ratio 1:1
- 6) Reference voltage 50 V DC

- 7) A = V<sub>S</sub> connections reverse-polarity protected
- C = Interference pulse suppression

Assignment of data bits (Host level)				Assignment of parameter bits (Host level)			
D <sub>0</sub>	Switching state	0 No reflection 1 Reflection	Input	P <sub>0</sub> *	NC	0 1	Parameter
D <sub>1</sub>	Alarm	0 active 1 inactive	Input	P <sub>1</sub> *	Light/dark selector	0 Dark-switching 1 Light-switching	Parameter
D <sub>2</sub>	NC	0 1	Input	P <sub>2</sub> *	NC	0 1	Parameter
D <sub>3</sub> *	Test function	0 Sender ON 1 Sender OFF	Output	P <sub>3</sub> *	NC	0 1	Parameter

\* Default setting = 1

**Scanning range**

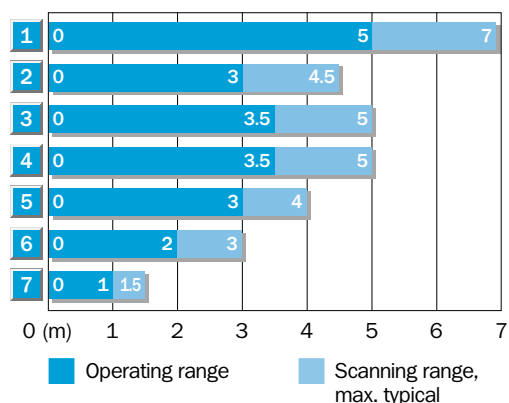

Reflector type	Operating range
1 PL 80 A	0...5.0 m
2 C 110	0...3.0 m
3 PL 50 A	0...3.5 m
4 PL 40 A	0...3.5 m
5 PL 30 A	0...3.0 m
6 PL 20 A	0...2.0 m
7 Reflective tape	0...1.0 m

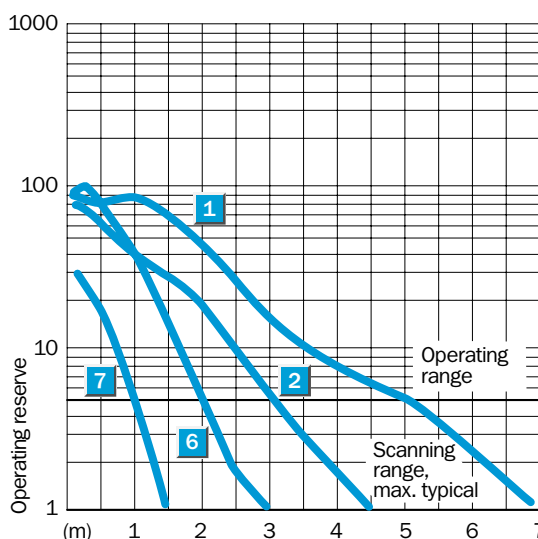

**Order information**

<b>Type</b>	<b>Part no.</b>
WL 12-2Z 430	1 016 108



 **Scanning range**  
2 m

Photoelectric reflex switches

- Red light
- Reliable detection of transparent objects
- Innovative microprocessor technology allows continuous adaptation of the switching threshold on contamination
- Operating range can be preselected via rotary switch or external cable



**Dimensional drawing**

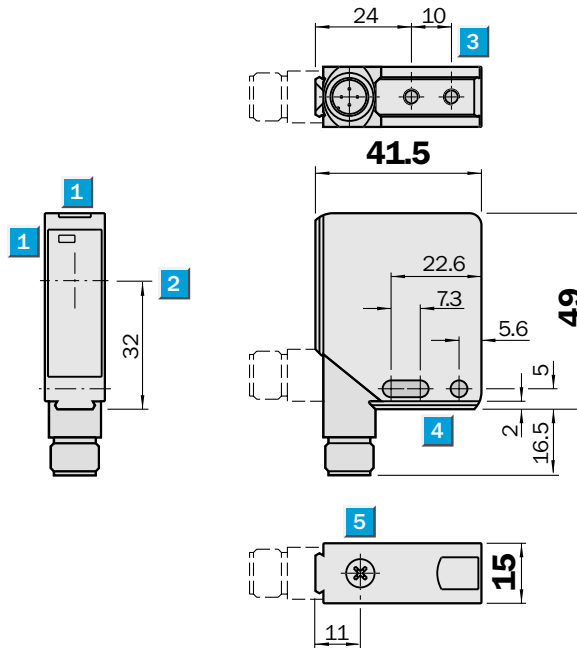

**Adjustments possible**

WL 12G-P 530	WL 12G-V 530
WL 12G-N 530	WL 12G-W 530

- 1** LED signal strength indicator
- 2** Centre of optical axis
- 3** M 4 threaded mounting hole – 4 mm deep
- 4** Mounting holes  $\varnothing$  4.2 mm
- 5** Function selector

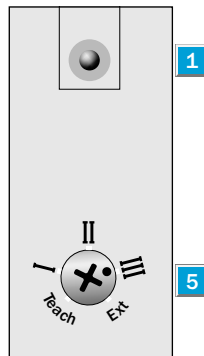

**Connection types**

WL 12G-P 530	WL 12G-V 530
WL 12G-N 530	WL 12G-W 530

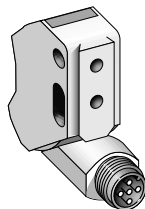

Accessories	page
Cable receptacles	496
Mounting brackets	510
Clamps*	510
Reflectors	520

\* 2 pieces included with delivery

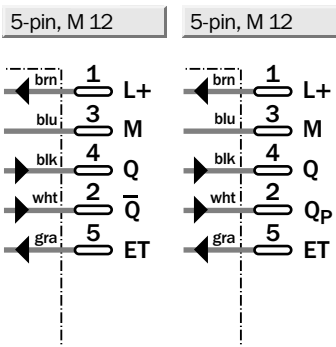

Technical data		WL 12G-	P 530	N 530	V 530	W 530
<b>Scanning range</b> , max. typical/on refl.	2 m/PL 80 A					
Sensitivity	adjustable					
<b>Light source<sup>1)</sup>, light type</b>	LED, red light					
Light spot size	Approx. 8 x 13 at 200 mm					
<b>Supply voltage <math>V_S</math></b>	10...30 V DC <sup>2)</sup>					
Ripple <sup>3)</sup>	$\leq 5 V_{SS}$					
Current consumption <sup>4)</sup>	$\leq 65$ mA					
<b>Transistor switching outputs</b>	PNP, Q and $\bar{Q}$					
	NPN, Q and $\bar{Q}$					
	PNP, Q and plausibility output					
	NPN, Q and plausibility output					
Output current $I_A$ max.	100 mA					
Resp. time <sup>5)</sup> /max. switching freq. <sup>6)</sup>	$\leq 0.5$ ms/1000 Hz					
Operating mode	Light-switching, Q active if light beam to reflector is unbroken					
<b>Plausibility output <math>Q_p</math></b>						
Reliable detection	Approx. 0 V					
	Approx. $+V_S$					
incorrect setting or severe pollution	$V_S - 2.9$ V					
	Approx. 1.8 V					
<b>Teach input ET</b>						
Teach-in	$\geq 10$ V to $+V_S$					
Normal operation	$< 2$ V or open input					
<b>Connection types</b>	M 12 plug, 5-pin					
<b>VDE protection class<sup>7)</sup></b>	<input type="checkbox"/>					
<b>Circuit protection<sup>8)</sup></b>	A, B, C					
<b>Enclosure rating</b>	IP 67					
<b>Ambient temperature <math>T_A</math></b>	Operation $-25$ °C... $+60$ °C Storage $-40$ °C... $+75$ °C					
<b>Weight</b>	With plug: 120 g					
<b>Polarising filter</b>						
<b>Housing material</b>	Zinc die-cast housing					

Operating range setting			Set via rotary switch on device or via ET cable ( $+V_S$ to ET)
<b>Mode I : 50 ms<sup>9)</sup></b>	<b>Mode II : 150 ms<sup>9)</sup></b>	<b>Mode III : 250 ms<sup>9)</sup></b>	
Switches at signal attenuation $> 10\%$	Switches at signal attenuation $> 18\%$	Switches at signal attenuation $> 40\%$	
Clean PET bottles	Clear-glass bottles	Coloured glass or non-transparent objects	

- 1) Average service life 100,000 h at  $T_A = +25$  °C
- 2) Limit values
- 3) May not exceed or fall short of  $V_S$  tolerances
- 4) Without load
- 5) Signal transit time with resistive load
- 6) With light/dark ratio 1:1
- 7) Reference voltage 50 V DC
- 8) A =  $V_S$  connections reverse-polarity protected  
B = Output Q and  $\bar{Q}$  short-circuit protected  
C = Interference pulse suppression
- 9) Pulse duration via ET (control cable), duration set via rotary switch approx. 2 s

**Operating range and operating reserve**

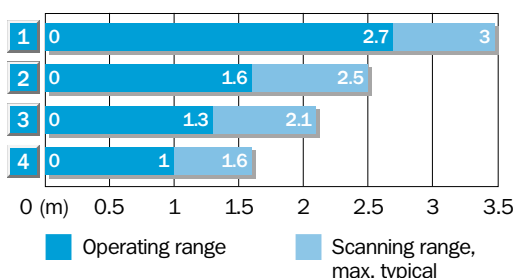

Reflector type	Operating range
1 PL 80 A	0...2.7 m
2 PL 40 A	0...1.6 m
3 PL 30 A	0...1.3 m
4 PL 20 A	0...1.0 m

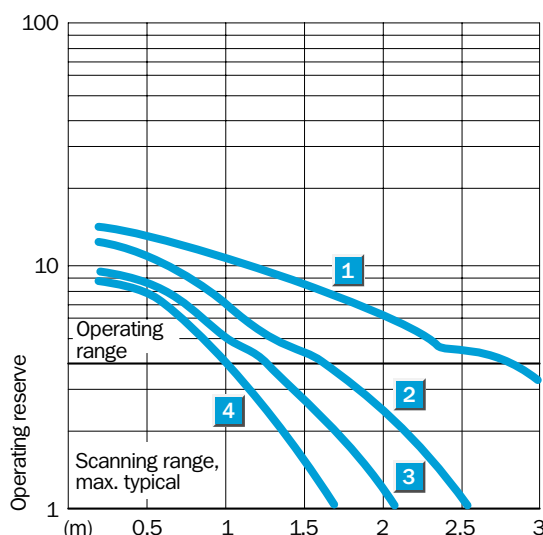

Order information	
Type	Part no.
WL 12G-P 530	1 016 289
WL 12G-N 530	1 016 309
WL 12G-V 530	1 016 310
WL 12G-W 530	1 016 311

**Scanning range**  
**4 m**

Photoelectric reflex switches

- Red light
- Insensitive to ambient light sources
- Detection of glass and transparent films
- Adjustable sensitivity

**Dimensional drawing**

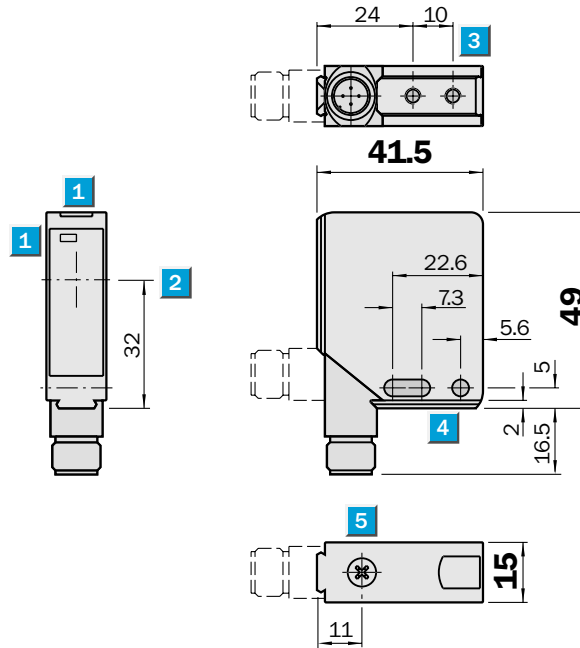

**Adjustments possible**

WL 12-2B 560

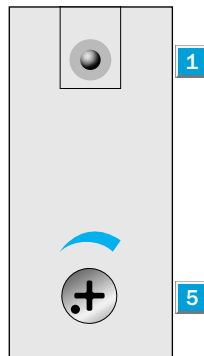

- 1 LED signal strength indicator
- 2 Centre of optical axis
- 3 M 4 threaded mounting hole – 4 mm deep
- 4 Mounting holes  $\varnothing$  4.2 mm
- 5 Sensitivity adjustment

**Connection type**

WL 12-2B 560

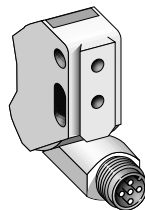

5-pin, M 12

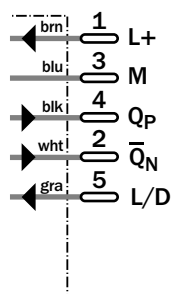

Accessories	page
Cable receptacles	496
Mounting brackets	510
Clamps*	510
Reflectors	520

\* 2 pieces included with delivery

<b>Technical data</b>		WL 12-	2B560								
<b>Scanning range</b> , max. typical/on refl.	4 m/PL 80 A										
Sensitivity	adjustable										
<b>Light source<sup>1)</sup>, light type</b>	LED, red light										
Light spot diameter	30 mm at 1.5 m										
<b>Supply voltage <math>V_S</math></b>	10...30 V DC <sup>2)</sup>										
Ripple <sup>3)</sup>	$\leq 5 V_{SS}$										
Current consumption <sup>4)</sup>	$\leq 30$ mA										
<b>Switching outputs</b>	Transistor outputs $Q_P$ and $Q_N$										
Output current $I_A$ max.	100 mA										
Response time <sup>5)</sup>	$\leq 330 \mu s$										
Max. switching frequency <sup>6)</sup>	1500 Hz										
Operating mode	Light- or dark-switching										
Control cable L/D	0 V or open-circuited $\leftrightarrow$ light-switching										
Control cable L/D	$V_S \leftrightarrow$ dark-switching										
<b>Connection type</b>	M 12 plug, 5-pin										
<b>VDE protection class<sup>7)</sup></b>	<input type="checkbox"/>										
<b>Circuit protection<sup>8)</sup></b>	A, B, C										
<b>Enclosure rating</b>	IP 67										
<b>Ambient temperature <math>T_A</math></b>	Operation -40 °C...+60 °C Storage -40 °C...+75 °C										
<b>Weight</b>	With plug: 120 g										
<b>Polarising filter</b>											
<b>Housing material</b>	Zinc die-cast housing										

- 1) Average service life 100,000 h at  $T_A = +25$  °C
- 2) Limit values
- 3) May not exceed or fall short of  $V_S$  tolerances
- 4) Without load
- 5) Signal transit time with resistive load
- 6) With light/dark ratio 1:1
- 7) Reference voltage 50 V DC
- 8) A =  $V_S$  connections reverse-polarity protected  
B = Output  $Q_P$  and  $Q_N$  short-circuit protected  
C = Interference pulse suppression

**Operating range and operating reserve**

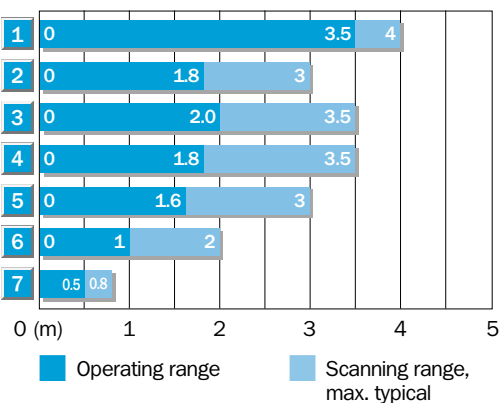

Reflector type	Operating range
1 PL 80 A	0...3.5 m
2 C 110	0...1.8 m
3 PL 50 A	0...2.0 m
4 PL 40 A	0...1.8 m
5 PL 30 A	0...1.6 m
6 PL 20 A	0...1.0 m
7 Reflective tape	0...0.5 m

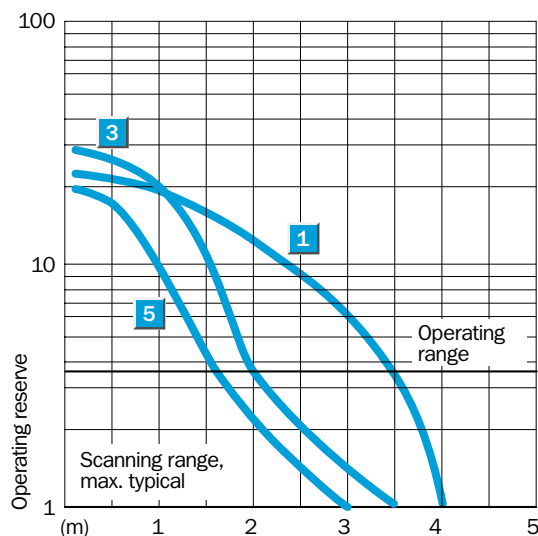

**Order information**

Type	Part no.
WL 12-2B 560	1 016 080

**Scanning range**  
20 m

Through-beam photoelectric switches

- Red light
- Insensitive to ambient light sources
- M 12 plug rotatable by 90°, or 2 m cable
- Adjustable sensitivity

**Dimensional drawing**

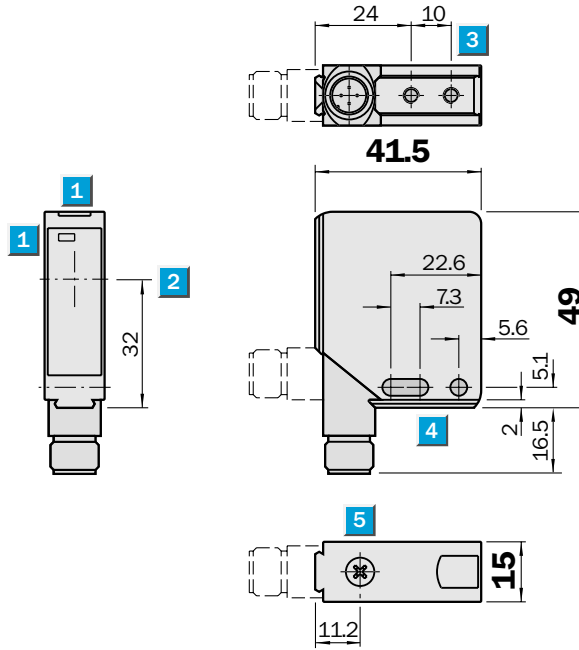

**Adjustments possible**

WS/WE 12-2P 430	WS/WE 12-2N 430
WS/WE 12-2P 130	WS/WE 12-2N 130

- 1 LED signal strength indicator
- 2 Centre of optical axis
- 3 M 4 threaded mounting hole – 4 mm deep
- 4 Mounting holes  $\phi$  4.2 mm
- 5 Sensitivity adjustments

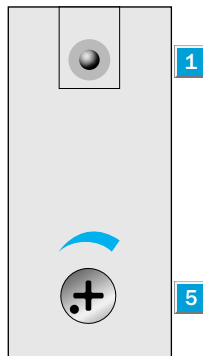

**Connection types**

WS/WE 12-2P 130	WS/WE 12-2P 430
WS/WE 12-2N 130	WS/WE 12-2N 430

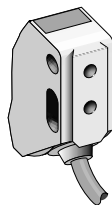

4 x 0.25 mm<sup>2</sup>

Sender

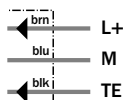

Receiver

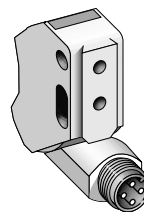
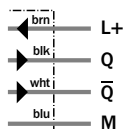

4-pin, M 12

Sender

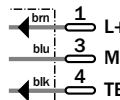

Receiver

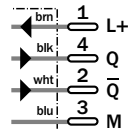

Accessories	page
Cable receptacles	496
Mounting brackets	510
Clamps*	510
Masks	556

\* 2 pieces included with delivery



Technical data		WS/WE 12-2	P 430	P 130	N 430	N 130
<b>Scanning range</b> , max. typical	20 m					
Sensitivity	adjustable					
Scanning range with 2 mm mask	2 m					
Scanning range with 1.5 mm mask	1.5 m					
Scanning range with 1 mm mask	1 m					
Scanning range with 0.5 mm mask	0.5 mm					
<b>Light source<sup>1)</sup>, light type</b>	LED, red light					
Light spot diameter	Approx. 500 mm at 15 m					
Angle of dispersion						
<b>Supply voltage <math>V_S</math></b>	10...30 V DC <sup>2)</sup>					
Ripple <sup>3)</sup>	$\leq 5 V_{SS}$					
Current consumption <sup>4)</sup>						
sender	$\leq 30$ mA					
receiver	$\leq 15$ mA					
receiver	$\leq 25$ mA					
<b>Switching output</b>	PNP, Q and $\bar{Q}$ NPN, Q and $\bar{Q}$					
Output current $I_A$ max.	100 mA					
Response time <sup>5)</sup>	$\leq 330 \mu\text{s}$					
Max. switching frequency <sup>6)</sup>	1500 Hz					
<b>Test input "TE" for light sender</b>						
Sender OFF	TE to 0 V					
<b>Connection types</b>	M 12 plug, 4-pin Cable <sup>7)</sup> , 2 m					
<b>VDE protection class<sup>8)</sup></b>	<input type="checkbox"/>					
<b>Circuit protection<sup>9)</sup></b>	A, B, C					
<b>Enclosure rating</b>	IP 67					
<b>Ambient temperature <math>T_A</math></b>	Operation -40 °C...+60 °C Storage -40 °C...+75 °C					
<b>Weight</b>	With plug: 120 g With cable: 200 g					
<b>Housing material</b>	Zinc die-cast housing					

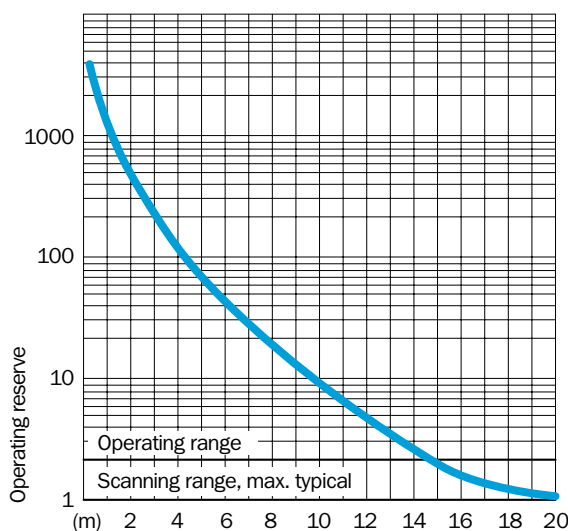
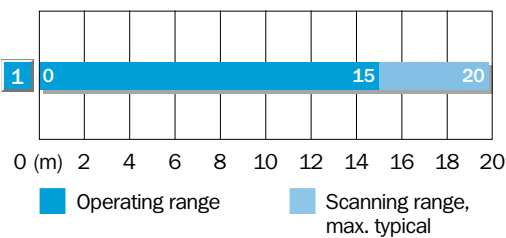

- 1) Average service life 100,000 h at  $T_A = +25$  °C
- 2) Limit values
- 3) May not exceed or fall short of  $V_S$  tolerances
- 4) Without load
- 5) Signal transit time with resistive load
- 6) With light/dark ratio 1:1
- 7) Do not bend below 0 °C
- 8) Reference voltage DC 50 V
- 9) A =  $V_S$  connections reverse-polarity protected  
B = Output Q and  $\bar{Q}$  short-circuit protected  
C = Interference pulse suppression

**Scanning range**



**Order information**

Type	Part no.
WS/WE 12-2P 430	1 016 157
WS/WE 12-2P 130	1 016 156
WS/WE 12-2N 430	1 016 155
WS/WE 12-2N 130	1 016 154

	<b>Scanning range up to 550 mm</b>
<b>Through-beam systems</b>	
	<b>Scanning distance up to 50 mm</b>
<b>Proximity systems</b>	

- Red, infrared or green light
- Plug-in fibre-optic cables
- Switch-selectable light-/dark-switching
- Adjustable sensitivity



**Dimensional drawing**

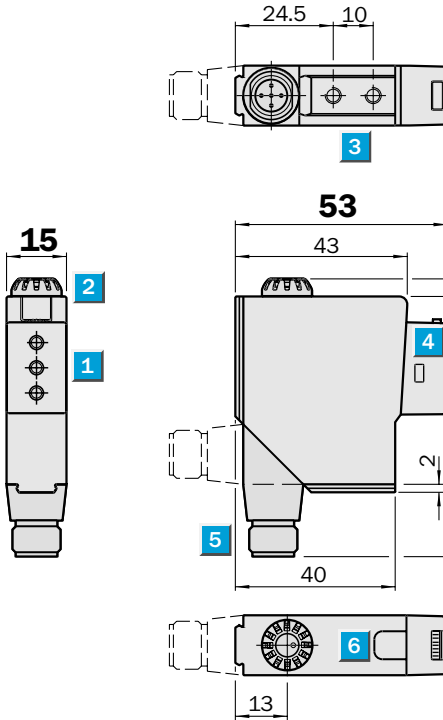

AD adapter* for		
Fibre-optic	Type	Part no.
LL 3-...	AD-LL-1M0	2 015 026
∅ (1.0 mm)		
LL 3-...	AD-LL-2M2	2 015 210
∅ (2.2 mm)		
LM/LT-...	AD-LL-GF	2 015 034
LH10-1000	AD-LL-HGA	2 015 033

\* not included with delivery

**Adjustments possible**

All types

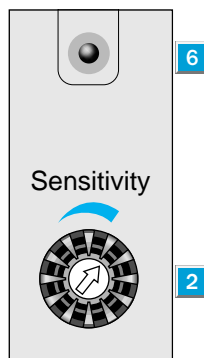

- 1 Connector for fibre-optic cable
- 2 Sensitivity control
- 3 M4 threaded mounting hole – 4 mm deep
- 4 Adapter
- 5 Plug not rotatable. Plug facing backwards on request
- 6 LED signal strength indicator

**Connection type**

All types

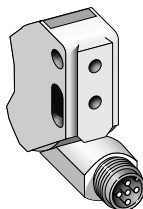

5-pin, M 12

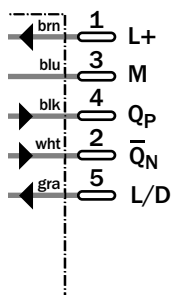

Accessories	page
Cable receptacles	496
Clamps*	510
Mounting brackets	510
Fibre-optic cables	528

\* 2 pieces included with delivery

Technical data		WLL 12-	B5181	B5281	B5381	B5481					
<b>Scanning distance/ scanning range, max.</b>	50/550 mm										
Fibre-optic cable	See Accessories on page 528										
Sensitivity	Adjustable										
<b>Scanning distance<sup>1)</sup></b>	10 mm ± 1 mm, fixed										
Background suppression											
<b>Light source<sup>2)</sup>, light type</b>	LED, red light <sup>3)</sup>										
	Infrared light <sup>4)</sup>										
	Green light <sup>5)</sup>										
<b>Supply voltage V<sub>S</sub></b>	10...30 V DC <sup>6)</sup>										
Ripple <sup>7)</sup>	≤ 5 V <sub>SS</sub>										
Current consumption <sup>8)</sup>	≤ 35 mA										
<b>Switching outputs</b>	PNP: Q/NPN: Q										
Output current I <sub>A</sub> max.	100 mA										
Switching cycles	1300/s										
Response time <sup>9)</sup>	360 μs										
Max. switching frequency <sup>10)</sup>	1300 Hz										
<b>Control input L/D</b>	Light-/dark-switching										
<b>Connection type</b>	Plug M 12, 5-pin										
	Plug facing downwards <sup>11)</sup>										
<b>VDE protection class<sup>12)</sup></b>	□										
<b>Circuit protection<sup>13)</sup></b>	A, B, C										
<b>Enclosure rating</b>	IP 67										
<b>Ambient temperature T<sub>A</sub></b>	Operation - 25 °C...+ 55 °C										
	Storage - 25 °C...+ 70 °C										
<b>Weight</b>	Approx. 130 g										
<b>Housing material</b>	Zinc die-cast housing										

- 1) With LH 10-1000 fibre-optic cable  
 2) Average service life 100,000 h at T<sub>A</sub> = + 25 °C  
 3) Preferably LL 3 fibre-optic cable  
 4) Preferably LM/LT fibre-optic cable

- 5) Preferably contrast detection  
 6) Limit values  
 7) May not exceed or fall short of V<sub>S</sub> tolerances  
 8) Without load

- 9) Signal transit time with resistive load  
 10) With light/dark ratio 1:1  
 11) Plug facing backwards on request  
 12) Reference voltage 50 V DC

- 13) A = V<sub>S</sub> connections reverse-polarity protected  
 B = Output Q and Q short-circuit protected  
 C = Interference pulse suppression

#### Proximity system with background suppression, WLL 12-B 5481 with LH 10-1000 fibre-optic cable

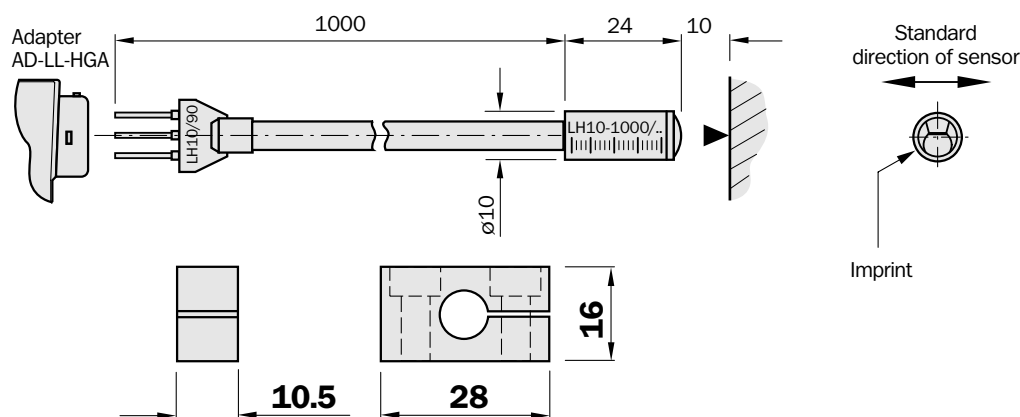

#### Order information

Type	Part no.
WLL 12-B 5181	1 011 677
WLL 12-B 5281	1 011 687
WLL 12-B 5381	1 011 688
WLL 12-B 5481	1 011 965
LH 10-1000	2 015 692
AD-LL-HGA	2 015 033
Bracket	4 028 164

<b>Scanning distance:</b>	10 mm (-1 mm), fixed
<b>Light spot diameter:</b>	approx. 2.5 x 3.5 mm
<b>Switching hysteresis :</b>	≤ 0.3 mm, based on standard white 90 % to standard black 6 %