

**Dead-man equipment
Foot switch
Series S293 S3**

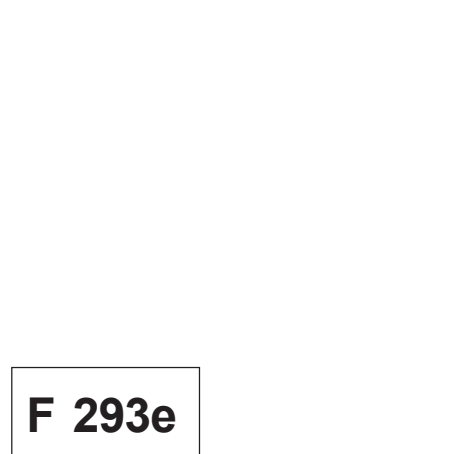
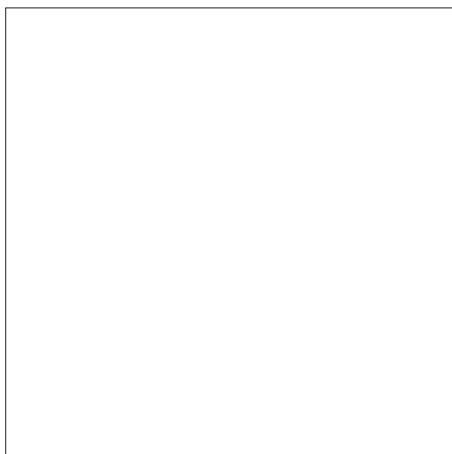
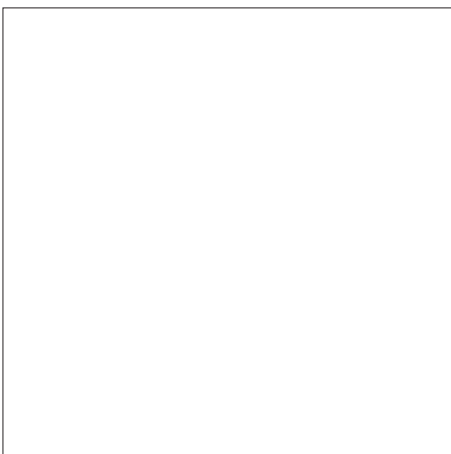
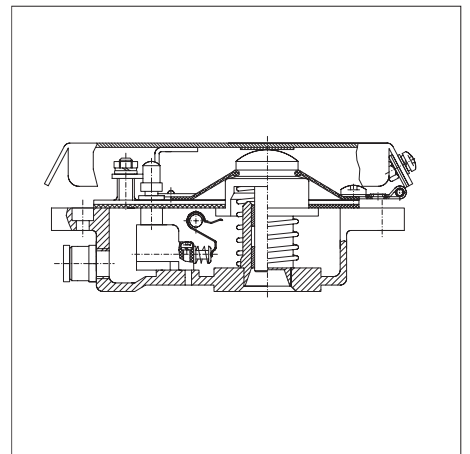
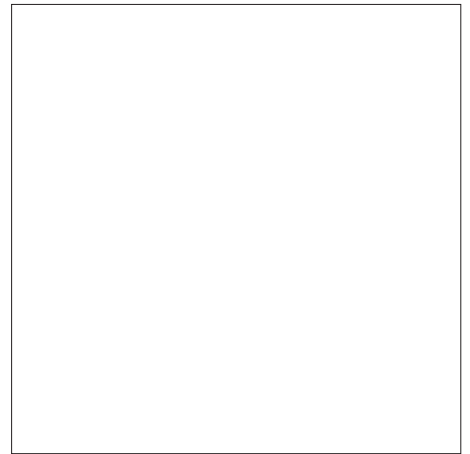

F 293e

Dead-man equipment, foot-switch series S293 S3

Series S293 S3 foot switch is used in the control circuits of electric and diesel locomotives, light rail cars. It has compact structure and can be actuated fastly. It's well sealed, dust-proof and has a long mechanical life.



S293 S3

Technical Data

Switching element	Snap action switch with positive opening operation series S 804b*
Contact type	each one NC + NO
Nominal operating voltage U_{nom}	220 V DC
Conventional thermal current I_{th}	10A
Rated impulse withstand voltage (U_{imp}) at conernmination degree	4 kV 3
Contacts	Silver (Ag)
Contact resistance	typical 10 m Ω
Terminals	M3 screw
Actuation force	approx. 35 N
Mechanical life	approx. 1,000,000 cycles
Shock and vibration resistance	5 g 20 ms / 3 g at 10 - 150 Hz
Protection degree according to DIN 40050	IP54
Weight	1.6 kg
Fixing / assembly	M4, max. torque 2 Nm
Ambient temperature range	-25°C to +45°C without limitation of electrical characteristics

* For further information see data sheet D20e

Device outline, Mounting template, Circuit diagram, Ordering information

Device outline:

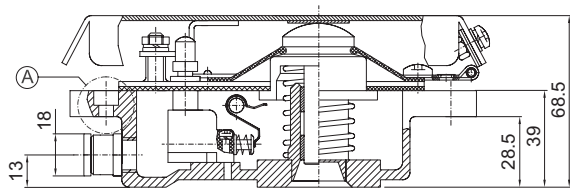

Detail A:

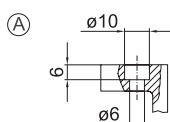

Circuit diagram:

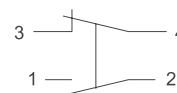

Mounting template:

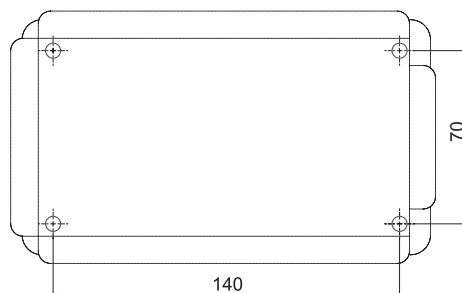
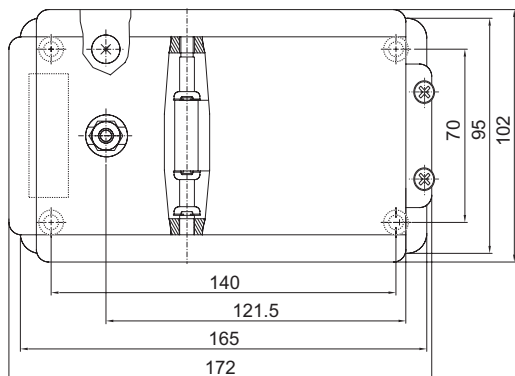

Ordering information:

Dead Man's Device Foot Switch Series

S293 S3